

Quazite[®]

UNDERGROUND ENCLOSURES AND PADS





Underground Enclosure Performance Specifications

Enclosures, boxes and covers are required to conform to all test provisions of the most current ANSI/SCTE 77 "Specification For Underground Enclosure Integrity" for Tier _____ (specify Tier 5, 8, 15 and/or 22) applications. When multiple "Tiers" are specified the boxes must physically accommodate and structurally support compatible covers while possessing the highest Tier rating. All covers are required to have the Tier level rating embossed on the surface. In no assembly can the cover design load exceed the design load of the box. All components in an assembly (box & cover) are manufactured using matched surface tooling. Independent third party verification or test reports stamped by a registered Professional Engineer certifying that all test provisions of this specification have been met are required with each submittal.

Table of Contents

Underground Enclosure Performance Specifications	2	Cover Drawings	50 - 53
Introduction to QUAZITE®	4 - 7	Replacement Cover Drawings.....	50 - 52
Engineering	4	Meter Reading Covers and Lids	53
Quality Assurance.....	4	Hardware and Options	54 - 60
What is Polymer Concrete?.....	5	Hardware	54
Why Use Polymer Concrete?	5	Self-Cleaning Auger Bolt Assembly.....	55
Design Possibilities.....	5	Secure Cover Lockdown Option.....	55
Enclosures (ANSI Compliant).....	6	Enclosure Options	56 - 57
Electrical Equipment Pads and Telecommunications Cabinet Pads.....	6	Standard Cable Rack Insert, Terminator, Knockout, & Hole Locations	58
Box Pads and Traffic Signal Cabinet Bases	6	Divided Boxes.....	59
National Electric Code, ANSI/SCTE 77, and UL Listing.....	7	Logos.....	59
QUAZITE® Enclosures UL Listed to ANSI/SCTE 77 2007.....	7	Pad Options.....	59
Testing Requirements for ANSI/SCTE 77 2007.....	7	Color Options.....	60
Enclosure Selection	8 - 14	Electrical Equipment Pads	61 - 69
Using the Selection Guide	8	Electrical Equipment Pad Selection Guide.....	61 - 64
UL Listed Enclosures.....	8	Switchgear Box Pad Cross Reference Guide.....	62
Load Ratings	9	Box Pad Drawings	65 - 66
Handhole Opening Sizes.....	10	Underground Distribution Switchgear Enclosure.....	67
Cover Series and Styles.....	11	Electrical Equipment Pad Drawings	68 - 69
Other Cover Styles	12	Telecommunications Cabinet Pads	70 - 79
Box Styles.....	13 - 14	Telecommunications Cabinet Pad Selection Guide.....	70 - 75
Enclosure Drawings	15 - 48	Telecommunications Cabinet Pad Cross Reference Guide.....	71 - 73
Index of Enclosure Drawings.....	15	Telecommunications Cabinet Pad Dimensions & Weights	76 - 77
6" x 8"	16	Cell Site Enclosure	78
8" x 8"	17	Cabinet Enclosure	79
8" x 18"	18	Transportation Industry Products	80 - 90
10" x 15"	19	Traffic Signal Cabinet Base Selection Guide.....	80 - 84
11" x 18"	20 - 21	Traffic Signal Cabinet Base Cross Reference Guide.....	81 - 82
11" x 20"	22	Traffic Signal Cabinet Base Drawings	85 - 86
12" x 12"	23 - 24	Combination Traffic Signal/Battery Backup Cabinet Bases.....	87
13" x 24"	25 - 28	Work Pad Drawing.....	88
17" x 30"	29 - 32	Jersey Style Median Barrier Enclosure Drawing	89 - 90
24" x 24"	33	Installation	91 - 102
24" x 36"	34 - 35	"ANSI Tier" Selection and Placement.....	91 - 92
30" x 48"	36 - 37	Small Enclosure Installation	93
30" x 60"	38	Hole Cutting Instructions	94
36" x 36"	39	EZ-Nut and Self-Aligning Nut Replacement Instructions.....	95
36" x 60"	40	Large Enclosure Installation	96
36" x 72"	41	Internal Bracing Installation	97
48" x 48"	42	Concrete Collar Applications	98
48" x 72"	43	Telecommunications Cabinet Pad Installation.....	99
48" x 96"	44	Traffic Signal Cabinet Base Installation.....	100
Grade Adjustable Extensions	45	Electrical Equipment Pad Installation	101
27" Round.....	46 - 47	Switchgear Box Pad Installation	102
39" Round.....	48 - 49	Company Information	103 - 106





QUAZITE® Products for Underground Construction

Introduction

Since 1971, QUAZITE® precast polymer concrete products have been used by utilities and contractors for durable, cost-effective applications. QUAZITE® encompasses a broad range of underground utility products including: service boxes and handholes, electrical equipment pads, telephone cabinet pads, CATV enclosures, water meter boxes, box pads and traffic signal cabinet bases.

QUAZITE® manufacturing/distribution centers are in Lenoir City, Tennessee and Juarez, Mexico providing nationwide service and prompt delivery.

Engineering

Registered professional engineers are on hand to assist with design, specification development and review. Full CAD capabilities are available and can be used to electronically transmit drawings and files to you. Product drawings can be accessed from our website:

www.quazite.com



QUAZITE® enclosures are embedded in concrete highway median barriers.

Quality Assurance

The Quality Assurance staff at each QUAZITE® manufacturing facility assures product consistency and conformance to customer specifications. The test labs and manufacturing processes at all QUAZITE® facilities are accepted by Underwriters Laboratories, Inc. (UL).

QUAZITE® underground products solve problems in thousands of specific applications in many industries. If one or more of the products described here could be the right solution for you, please contact your local QUAZITE® representative for more information.



QUAZITE® switchgear box pads are used for easier, quicker and less expensive installations.



Precast Polymer Concrete

What Is Polymer Concrete?

Polymer concrete is made from selectively-graded aggregates in combination with a polymer resin system. When combined through a process of mixing, molding and curing, an extremely powerful cross-linked bond is formed. Precast polymer concrete is reinforced with fiberglass for exceptional strength and rigidity.

Why Use Polymer Concrete?

- **Lightweight** — 1/10 to 1/3 the weight of concrete
- **High Strength** — compressive, flexural and tensile strengths three to five times higher than traditional concrete
- **Reduced Installation Costs** — easy to handle, no special equipment required
- **Stable Under Freeze/Thaw Conditions**
- **Impact Resistant** — tested per ASTM D-2444
- **Low Water Absorption** — less than 1% per ASTM D-570
- **Corrosion Resistant** — resistant to alkalines, acids, weathering and other forms of deterioration
- **Cost Effective** — outperforms conventional materials for longer service and lower life cycle costs
- **Nonflammable** — will not support combustion
- **Nonconductive** — no grounding required for the box or cover

Design Possibilities

Precast polymer concrete offers a variety of design possibilities.

- **Development of New Parts** — Years of experience enable QUAZITE® engineers to produce custom designed parts to your specifications.
- **Size** — Monolithic boxes are being made up to 4' x 8' x 4'. Pads for cabinets or equipment enclosures are currently being made as small as 25" x 38" and as large as 93" x 93" and even larger when bolted together. If other sizes are required, contact your local QUAZITE® representative.
- **Composite Design** — An experienced staff is available to assist in the development of specifications and design of products.
- **Custom Accessories** — Many options are available for QUAZITE® products, including racking and struts, knockouts, holes, logos, terminators, gaskets, pulling eyes, and numerous other options. Please see pages 54 - 60 for a complete listing of options.



The strong polymer concrete construction allows QUAZITE® enclosures to be stacked for even greater depths.

Typical Properties of Polymer Concrete

Mechanical Properties

Modulus of elasticity	1 to 2.4 x 10 ⁶ psi
Compressive strength	9,000-15,000 psi
Flexural strength	3,000-6,000 psi
Impact energy	30-72 ft.-lbs.
Tensile strength	800-1,100 psi

Physical Properties

Freeze/thaw resistance (2,500 cycles)	No significant change
Density	85-150 lbs./cu. ft.
Barcol hardness	45
Coefficient of friction (covers)	Greater than 0.5
Water absorption	Less than 1%

Chemical Resistance - per ANSI/SCTE 77, Section 4

Tested according to the requirements of ASTM Method D-543, Section 7, Procedure 1 for chemical resistance, using the following chemicals in the concentrations noted:

CHEMICAL	CONCENTRATION
Sodium Chloride	5%
Sulfuric Acid	0.1N
Hydrochloric Acid	0.2N
Sodium Hydroxide	0.1N

Properties will vary depending upon the particular formulation. Customized properties can be achieved by using nonstandard resins, by changing or adding reinforcements, and by tailoring the overall composite design.



The Product Line



QUAZITE® has a broad product line for the underground construction industry.

Enclosures

For use as splice boxes, pull boxes or equipment enclosures for any application requiring easy access to an underground service (i.e. electrical, telephone, fiber optics, CATV, water, gas, etc.). Available in a large variety of sizes and styles with either standard, heavy duty or optional overlapping covers. No grounding is required for the box or cover. Fits flush with sidewalk or grass area. Covers are skid resistant. Replacement covers and meter lids, hardware, inserts and grade adjustable extensions are available options. Boxes and covers are ANSI/SCTE 77 compliant for intended applications.



Electrical Equipment and Telecommunications Cabinet Pads

Used under transformers and telephone cabinets to add stability, prevent corrosion of metal cabinets, provide a fire break, and protect cabinets from damage caused by mowing equipment. Available as a solid pad or as a Splitt-Pad® for easy retrofits.

Box Pads and Traffic Signal Cabinet Bases

Precast polymer concrete box pads and traffic signal cabinet bases eliminate forming and pouring and are lightweight, resulting in easy handling and a lower installed cost. Excavation and installation of the entire unit can be done in one day. Can be reused in other locations.

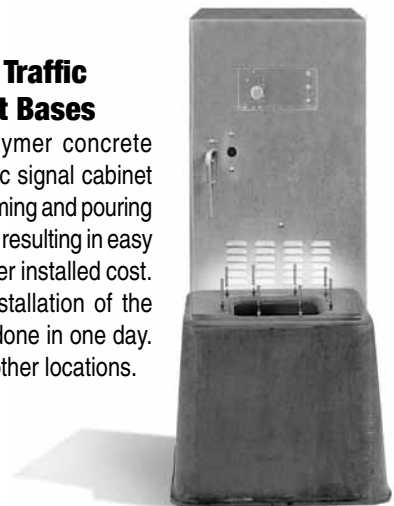

National Electric Code, ANSI/SCTE 77, and UL Listing

NEC and Underground Enclosures

The National Electric Code states in article 314.30 that enclosures “shall be designed and installed to withstand all loads likely to be imposed,”¹ and addresses issues related to enclosure size, wiring entries, enclosures without bottoms, and bonding requirements for covers.

The *Code* references the ANSI/SCTE 77² “Specification for Underground Enclosure Integrity” National Standard³, which outlines various tests that enclosures must pass to meet the standard. ANSI/SCTE 77 also provides load charts with Tier ratings to help end users determine the appropriate enclosure to select depending on the loadings expected in the application.

QUAZITE® Enclosures UL Listed to ANSI Standard

All QUAZITE® enclosures meet or exceed the test provisions of ANSI/SCTE 77 2007 and most enclosures sized 30” x 48” and smaller are UL Listed to the ANSI National Standard as referenced in the 2005 & 2008 *NEC*. This means that QUAZITE® enclosures have undergone rigorous physical, environmental and internal equipment protection tests and have been found by UL, a neutral third party, to meet the test requirements of the ANSI National Standard.

No one wants to be responsible for an accidental electrocution from a collapsed enclosure or energized cover. By using the *NEC*, ANSI/SCTE 77, and UL Listing requirements in the enclosure

selection process, end-users will help ensure long service life, increased safety and reduced potential liability associated with failed underground enclosures.

Testing Requirements for ANSI/SCTE 77 2007

Underground enclosures must successfully pass numerous material and product performance tests before they can meet ANSI/SCTE 77 2007. These tests include:

- Three Position Load Testing to Simulate Actual Application
- UV Degradation per ASTM G-154
- Fire Resistance per RUS 7CFR 1755.910 (PE-91)
- Chemical Resistance per ASTM D-543
- Water Absorption per ASTM D-570
- Impact Resistance per ASTM D-2444
- Accelerated Service per ASTM D-756, Procedure E

NOTE: Quazite recommends testing by third party organizations such as UL to verify that enclosures meet all test provisions of ANSI/SCTE 77.

1 National Fire Protection Agency, *2005 & 2008 National Electric Code*.

2 Subsequent to the issuance of the 2005 NEC, ANSI approved an updated version of the standard, ANSI/SCTE 77 2007.

3 The latest copy of the standard may be purchased from ANSI. It may also be viewed in PDF form on SCTE’s website at www.scte.org/documents/pdf/ANSISCTE%2077%202007.pdf.



Enclosure Selection Guide

To Select the Enclosure You Need for Your Application:

- 1 Determine UL Requirements
- 2 Determine Load Ratings
- 3 Determine Handhole Opening Size
- 4 Select Cover Series & Style
- 5 Select Box Style
- 6 Determine Options & Hardware

Using The Selection Guide

Follow the steps outlined in this guide to select the enclosure for your application. These steps will take you through the typical decisions necessary to determine the proper size and style enclosure for your application. **The UL Listed enclosures are highlighted throughout this selection guide to help in identifying them.**

A detailed product information listing follows the selection guide. All QUAZITE® products are listed here by size and style with dimensions and ordering information.

For more information or for answers to any questions you might have, call your local QUAZITE® representative. Detailed product drawings can be viewed from our website:

www.quazite.com



Most QUAZITE® underground enclosures in sizes through 30" x 48" are UL Listed.

1 UL Listed Enclosures

Determine if a UL Listed enclosure is required for your installation. Federally funded electrical and telecom projects, as well as many state and municipal projects, generally require the use of a UL Listed product whenever one is available.

Most QUAZITE® underground handhole enclosures in sizes through 30" x 48" are UL Listed. These products are clearly marked with the UL label on both the box and underneath the cover. Special order boxes with holes (or mouseholes, etc.) may qualify for UL Listing as long as the holes do not exceed more than 25% of the area of each sidewall and as long as the holes do not cut into a structural reinforcing rib, corner, or box lip.

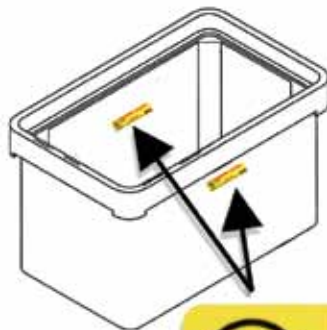
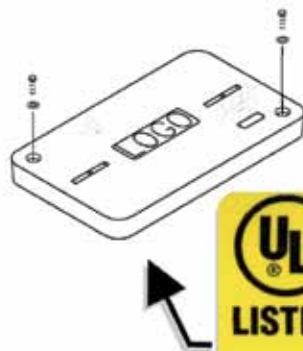

Highlighted areas indicate UL Listing

Enclosure Selection Guide

2 Load Ratings

QUAZITE® underground handhole enclosures are designed to meet or exceed the tier loadings set forth in the American National Standards Institute's ANSI/SCTE 77 2007 "Specification for Underground Enclosure Integrity"¹. ANSI tier designations are minimum specifications used by the industry to ensure the safe and reliable performance of underground handhole enclosures.

The ANSI application tier number relates to a nominal design load times 1,000 pounds (i.e.: Tier 8 = 8 x 1,000 lbs. = 8,000 lbs.). All ANSI tier loadings will have a corresponding test load which is 50% greater than the design load. The maximum deflection at the indicated design load shall be 1/2 inch for vertical tests and 1/4 inch per foot of length for lateral tests.

Three Position Testing

A key requirement outlined in ANSI/SCTE 77 2007 is three position testing for enclosures. Three position testing is required to determine how a product will perform in actual use.

In order to qualify a product's performance, test loading should be performed at the lateral center of the longest sidewall, at the vertical center of the longest sidewall, and at the vertical in the center of the cover. QUAZITE® products have been tested to each of the three positions as required by ANSI and all have met or exceeded the requirements.

- 1 Electronic file available at www.scte.org/documents/pdf/ANSISCTE%2077%202007.pdf.
- 2 Some QUAZITE® products are currently not UL Listed. Refer to pg. 15 for a complete listing of products.

To Select the Enclosure You Need for Your Application:

- 1..... Determine UL Requirements
- 2..... Determine Load Ratings
- 3..... Determine Handhole Opening Size
- 4..... Select Cover Series & Style
- 5..... Select Box Style
- 6..... Determine Options & Hardware

Application Tiers & Static Vertical Wheel Load Ratings per ANSI/SCTE 77 2007 "Specification for Underground Enclosure Integrity"

NOTE - QUAZITE® products are not intended for use in deliberate traffic areas.

Application Tiers	Loading Requirements				UL Listed to meet ANSI 77 Requirements ²
TIER 5¹ Sidewalk applications with a safety factor for occasional non-deliberate vehicular traffic	Vertical	Design Load Test Load	22.2 kN 33.3 kN	5,000 lbs. 7,500 lbs.	PC 13"x24" or PC 17"x30" style enclosure and cover assemblies with standard covers (CA) and standard covers w/o bolts (WA).
	Lateral	Design Load Test Load	28.7 kPa 43.1 kPa	600 lbs./sq. ft. 900 lbs./sq. ft.	
TIER 8¹ Sidewalk applications with a safety factor for non-deliberate vehicular traffic	Vertical	Design Load Test Load	35.6 kN 53.4 kN	8,000 lbs. 12,000 lbs.	PG and PT style enclosure and cover assemblies up to 30" x 48" and PC style in sizes 6"x8", 8"x18", 11"x18" and 12"x12" with standard covers (CA) and standard covers w/o bolts (WA).
	Lateral	Design Load Test Load	28.7 kPa 43.1 kPa	600 lbs./sq. ft. 900 lbs./sq. ft.	
TIER 15¹ Driveway, parking lot, and off-roadway applications subject to occasional non-deliberate heavy vehicular traffic	Vertical	Design Load Test Load	66.7 kN 100.1 kN	15,000 lbs. 22,500 lbs.	PG, PT and PC style enclosure and cover assemblies up to 30"x48" with heavy duty covers (HA).
	Lateral	Design Load Test Load	38.3 kPa 57.5 kPa	800 lbs./sq. ft. 1,200 lbs./sq. ft.	
Tier 22¹ Driveway, parking lot, and off-roadway applications subject to occasional non-deliberate heavy vehicular traffic	Vertical	Design Load Test Load	100.1 kN 150.1 kN	22,500 lbs. 33,750 lbs.	PC, PD, PG and PT style enclosure and cover assemblies up to 30" x 48" with extra heavy duty covers (HH).
	Lateral	Design Load Test Load	38.3 kPa 57.5 kPa	800 lbs./sq. ft. 1,200 lbs./sq. ft.	
AASHTO H-20 Deliberate vehicular traffic applications ONLY. Quazite does not currently offer any enclosures for this application tier.	Certified precast concrete, cast iron or other AASHTO recognized materials.* *There are no AASHTO design or test provisions for polymer composites. Therefore there is no recognized method of testing for qualification. Applying other material testing methods to polymer composites is not recognized by AASHTO. BUYER BEWARE !				

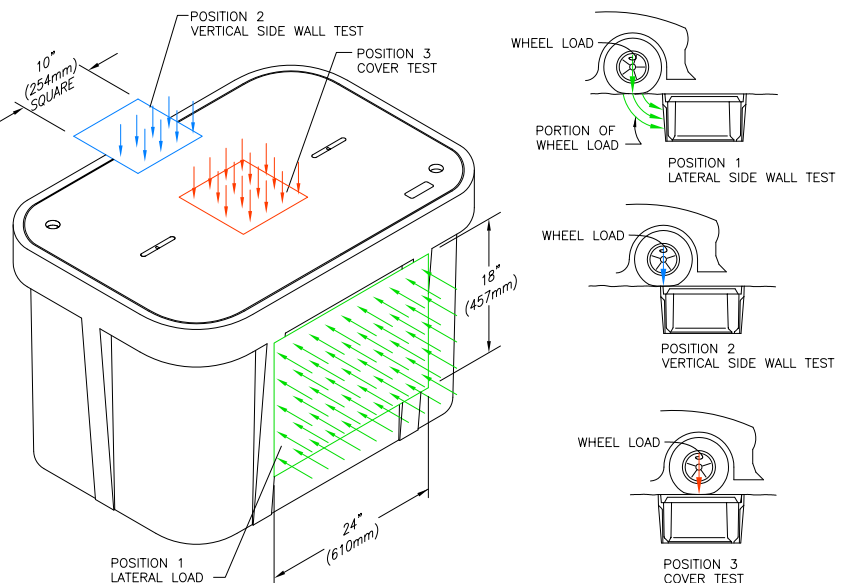

Figure 4.1 from ANSI/SCTE 77 2007

Enclosure Selection Guide

3 Handhole Opening Sizes

Box & Cover	
Style Available	Size
PC	6" x 8"
PC	8" x 8"
PC	8" x 18"
PT	10" x 15"
PG & PC	11" x 18"
PG	11" x 20"
PC & PX	12" x 12"
PG, PC, PD & PT	13" x 24"
PG, PC, PD & PT	17" x 30"
PG	24" x 24"
PG & PD	24" x 36"
PG & PD	30" x 48"
PG	30" x 60"
PG	36" x 36"
PG	36" x 60"
PG	36" x 72"
PG	48" x 48"
PG	48" x 72"
PG	48" x 96"

To Select the Enclosure You Need for Your Application:

- 1 Determine UL Requirements
- 2 Determine Load Ratings
- 3 Determine Handhole Opening Size**
- 4 Select Cover Series & Style
- 5 Select Box Style
- 6 Determine Options & Hardware



QUAZITE® enclosures are used for underground fiber optics and electric cable.



QUAZITE® enclosures are lightweight for easy installation.



Quazite keeps a large inventory of QUAZITE® enclosures to ensure immediate availability.

Highlighted areas indicate UL Listing





To Select the Enclosure You Need for Your Application:

- 1 Determine UL Requirements
- 2 Determine Load Ratings
- 3 Determine Handhole Opening Size
- 4 Select Cover Series & Style**
- 5 Select Box Style
- 6 Determine Options & Hardware

Enclosure Selection Guide

4 Cover Series & Styles

CA/WA/CG Series Covers

CA covers are designed to bolt down. WA covers do not have provisions to bolt the covers in place. CG covers feature a grommet package to reduce incoming fluids into the enclosure. CG covers must be used with gasketed boxes.

- Design Load: 8,000 lbs. over a 10" square with a minimum test load of 12,000 lbs. (ANSI Tier 8)
(For PG, PT, PR and smaller PC styles)
- Design Load: 5,000 lbs. over a 10" square with a minimum test load of 7,500 lbs. (ANSI Tier 5)
(For PC 13" x 24" and PC 17" x 30" styles and all LG styles)

HA/HG Series Covers

Heavy duty covers (available for PG, PD, PC and PR box styles) are designed for driveways, parking lots and off-roadway applications where subject to occasional non-deliberate vehicular traffic. HG covers feature a grommet package to reduce incoming fluids into the enclosure. HG covers must be used with gasketed boxes.

- Design Load: 15,000 lbs. over a 10" square with a minimum test load of 22,500 lbs. (ANSI Tier 15)

HH Series Covers

Extra heavy duty HH covers are designed for driveways, parking lots and off-roadway applications where subject to occasional non-deliberate traffic by heavy vehicles. Contact your local QUAZITE® representative for availability of sizes.

- Design Load: 22,500 lbs. over a 10" x 20" area with minimum test load of 33,750 lbs. (ANSI Tier 22)

Cover Load Rating

QUAZITE® Cover Performance Chart (Wheel Loads)*

Cover		Design (lbs.)	Test Load (lbs.)	Test Area	ANSI Tier
Style	Series				
LG	CA/WA	5,000	7,500	10" x 10"	5
PC1324 & PC1730	CA/WA	5,000	7,500	10" x 10"	5
PC all other sizes	CA/WA	8,000	12,000	10" x 10"	8
PG/PT	CA/WA	8,000	12,000	10" x 10"	8
PC	HA	15,000	22,500	10" x 10"	15
PG/PT	HA	15,000	22,500	10" x 10"	15
PG	HH	22,500	33,750	10" x 20"	22
PR	CA/WA	8,000	12,000	10" x 10"	8
PR	HA	15,000	22,500	10" x 10"	15

* Not all products are UL Listed. For specific UL Listed products, please refer to individual drawings.

Cover Numbering System

Cover Style	Cover Size	Cover Series	Cover Variation	Cover Logo #	Bolt Option
PC	1730	CA	00	09	P
<ul style="list-style-type: none"> PC PG PR PT LG 	(width x length) example: 17" x 30"	<ul style="list-style-type: none"> CA-standard cover HA-heavy duty cover WA-standard/no bolts CG-standard cover w/gasket HG-heavy duty cover w/gasket CS-split cover HS-heavy duty split cover CT-torsion assist cover HH-extra heavy duty CC-overlapping cover HC-heavy duty overlapping cover 	Standard Cover - No Variation Contact your local QUAZITE® representative for more information on cover variations.	09 - Blank (See chart on next page for a listing of commonly used cover logos)	Penta-head (Hex head bolts stan- dard, no designation needed)
<p>Highlighted areas indicate UL Listing</p>					



To Select the Enclosure You Need for Your Application:

- 1 Determine UL Requirements
- 2 Determine Load Ratings
- 3 Determine Handhole Opening Size
- 4 Select Cover Series & Style**
- 5 Select Box Style
- 6 Determine Options & Hardware

4 Other Cover Styles

LG Style Covers

32% lighter in weight as compared to the PG covers.

- Design Load: 5,000 lbs. over a 10" square with a minimum test load of 7,500 lbs. (ANSI Tier 5)

Overlapping Covers

Available in sizes 30" x 48", 30" x 60", and 36" x 60". Eliminates soil infiltration and allows for easy cover removal. Not recommended for sidewalks.



- Design Load: Available in either CA or HA ratings. (ANSI Tier 5, 8 or 15)

Replacement Covers

Covers that are interchangeable with several manufacturers' products include: PG1324, PG1730, PG2436, and PG3048. Other styles and sizes are also available.

- Design Load: Load Ratings will vary. Contact your local QUAZITE® representative for more information.

Meter Reading Lids

Available in PG style covers.

- Adding a meter lid to a Tier 8 cover reduces the rating to Tier 5. A Tier 5 cover will be reduced to a pedestrian traffic only rating.



Commonly Used Cover Logos

09 Blank	26 High Voltage
10 C.A.T.V.	29 Lighting
12 Communications	41 Street Lighting
14 Controls	43 Telephone
17 Electric	44 Traffic
21 Fiber Optics	46 Traffic Signal
24 Ground	50 Water

(See pg. 59 for additional logos)

Meter Reading Lid Numbering System

Cover Style	Cover Size	Cover Series	Cover Variation	Lid Position	Cover Logo #
PG	1730	CA	L	0	50
(Meter reading lids available only in PG style)	(width x length) example: 17" x 30"	CA - bolt down cover WA - standard/no bolts	R - Cast iron 4 1/2" x 7 1/2" lid P - Cast iron 6" x 9" lid Q - Cast iron 9" x 12" lid K - Polymer concrete 6" x 9" drop-in lid L - Polymer concrete 7" x 13" drop-in lid S - Through slot (no meter lid)	2 - Opens under 90° 0 - Used with drop-in lid (As standard, all meter lids are centered on the cover)	50 - Water (See chart above for a listing of commonly used cover logos)

Highlighted areas indicate UL Listing



To Select the Enclosure You Need for Your Application:

- 1 Determine UL Requirements
- 2 Determine Load Ratings
- 3 Determine Handhole Opening Size
- 4 Select Cover Series & Style
- 5 Select Box Style**
- 6 Determine Options & Hardware



Enclosure Selection Guide

5 Box Styles

PG Style

For use as a splice box, pull box, equipment enclosure or for any application requiring easy access to an underground service. Stackable for increased depth. Straight sides for easy adjustment of box to grade.



- Available in sizes:

11" x 18"	17" x 30"	30" x 48"	36" x 60"	48" x 72"
11" x 20"	24" x 24"	30" x 60"	36" x 72"	48" x 96"
13" x 24"	24" x 36"	36" x 36"	48" x 48"	

- Loadings comply with ANSI/SCTE 77. These boxes, with a design load of 22,500 lbs. and a test load of 33,750 lbs., meet ANSI Tier 22 test provisions.
- 12" - 48" depths
- Lightweight versions are also offered. Contact your local QUAZITE® representative for availability.

PD Style

Enclosures with 1° (degree) flare for maximum strength. Flared design optimizes internal volume and prevents frost heave.



- Available in sizes:
13" x 24 x 18", 13" x 24" x 26", 17" x 30" x 18", 17" x 30" x 26",
24" x 36" x 18", 24" x 36" x 26", 24" x 36" x 48", 30" x 48" x 24",
30" x 48" x 48"
- Design load: 22,500 lbs. Test load: 33,750 lbs. (ANSI Tier 22)

Box Numbering System

QUAZITE® products are referred to by an identifying part number. An example of the numbering system is shown below to help you understand how to identify the product you need for your application. Contact your local QUAZITE® representative if you have any questions.

Box Style	Nominal Size	Box Variation	Box Depth																		
PG	1730 (width x length) example: 17" x 30"	BA	12 12" deep																		
<table border="1"> <tr><td>PC</td><td>PT</td></tr> <tr><td>PG</td><td>PX</td></tr> <tr><td>PR</td><td>PR</td></tr> <tr><td>PD</td><td></td></tr> </table>	PC	PT	PG	PX	PR	PR	PD			<table border="1"> <tr><td>BA-box w/open bottom</td><td>DG- gasketed box w/solid bot- tom</td></tr> <tr><td>BB-box w/mouse holes</td><td>JA-footed box</td></tr> <tr><td>BC-divided box</td><td>EA-extension</td></tr> <tr><td>BG-gasketed box w/open bot- tom</td><td>RA-solid base extension</td></tr> <tr><td>DA-box w/solid bottom</td><td></td></tr> </table>	BA-box w/open bottom	DG- gasketed box w/solid bot- tom	BB-box w/mouse holes	JA-footed box	BC-divided box	EA-extension	BG-gasketed box w/open bot- tom	RA-solid base extension	DA-box w/solid bottom		
PC	PT																				
PG	PX																				
PR	PR																				
PD																					
BA-box w/open bottom	DG- gasketed box w/solid bot- tom																				
BB-box w/mouse holes	JA-footed box																				
BC-divided box	EA-extension																				
BG-gasketed box w/open bot- tom	RA-solid base extension																				
DA-box w/solid bottom																					

Highlighted areas indicate UL Listing



ENCLOSURE SELECTION

To Select the Enclosure You Need for Your Application:

- 1 Determine UL Requirements
- 2 Determine Load Ratings
- 3 Determine Handhole Opening Size
- 4 Select Cover Series & Style
- 5 Select Box Style**
- 6 Determine Options & Hardware**

5 Box Styles

ENCLOSURE SELECTION

PC Style

Straight sides permit easy movement of box should grade level change. Gasketing also available. All sizes are stackable.



- Sizes: 6" x 8", 8" x 18", 11" x 18" and 12" x 12"
Design load: 15,000 lbs. Test load: 22,500 lbs. (ANSI Tier 15)
- Sizes: 13" x 24" and 17" x 30"
Design load: 5,000 lbs. Test load: 7,500 lbs. (ANSI Tier 5)
- Sizes: 8" x 8"
Design load: 22,500 lbs. Test load: 33,750 lbs. (ANSI Tier 22)
- 6" - 18" depths

PX Style

Service box assemblies with flared sides. Nestable for compact storage.



- Size: 12" x 12" x 24"
Design load: 15,000 lbs.
Test load: 22,500 lbs. (ANSI Tier 15)

PT Style (previously called PE style)

Flared design prevents frost heave. Covers are interchangeable with many precast concrete parts. Nestable for compact storage.



- Sizes: 10" x 15", 13" x 24", 17" x 30"
- Design load: 15,000 lbs. Test load: 22,500 lbs. (ANSI Tier 15)
- 18" deep

PR Style

Round enclosures. Cover cannot fall into the box.



- Available in sizes:
27" dia. x 36" deep
39" dia. x 18", 24", 36" & 48" depths.
- Design load: 22,500 lbs. Test load: 33,750 lbs. (ANSI Tier 22)

6 Hardware and Options

See Hardware and Options Section, pages 54 - 60.

Highlighted areas indicate UL Listing

Index of Enclosure Drawings

Box Size	ANSI/SCTE* Tier (for Box)	Box Vertical Design/Test Load #	CA Cover Design/Test Load #	HA Cover Design/Test Load #	HH Cover Design/Test Load#	Box Style	Cover Style	Page No.
----------	---------------------------	---------------------------------	-----------------------------	-----------------------------	----------------------------	-----------	-------------	----------

SMALL ENCLOSURES

Ⓞ 6 x 8	15	15,000 / 22,500	—	15,000 / 22,500	—	PC	PC	16
Ⓞ 8 x 8	22	22,500 / 33,750	8,000 / 12,000	15,000 / 22,500	22,500 / 33,750	PC	PC	17
Ⓞ 8 x 18	15	15,000 / 22,500	8,000 / 12,000	15,000 / 22,500	—	PC	PC	18
10 x 15	15	15,000 / 22,500	8,000 / 12,000	15,000 / 22,500	—	PT	PG	19
Ⓞ 11 x 18	22	22,500 / 33,750	8,000 / 12,000	15,000 / 22,500	22,500 / 33,750	PG	PG	20
Ⓞ 11 x 18	15	15,000 / 22,500	8,000 / 12,000	15,000 / 22,500	—	PC	PC	21
11 x 20	22	22,500 / 33,750	8,000 / 12,000	15,000 / 22,500	22,500 / 33,750	PG	PG	22
Ⓞ 12 x 12	15	15,000 / 22,500	8,000 / 12,000	15,000 / 22,500	—	PC	PC	23
12 x 12	15	15,000 / 22,500	8,000 / 12,000	15,000 / 22,500	—	PX	PC	24
Ⓞ 13 x 24	22	22,500 / 33,750	8,000 / 12,000	15,000 / 22,500	22,500 / 33,750	PG	PG	25 - 26
13 x 24	22	22,500 / 33,750	5,000 / 7,500	15,000 / 22,500	22,500 / 33,750	PD	PG	25 - 26
Ⓞ 13 x 24	5	5,000 / 7,500	5,000 / 7,500	—	—	PC	PC	27
Ⓞ 13 x 24	15	15,000 / 22,500	8,000 / 12,000	15,000 / 22,500	—	PT	PG	28
Ⓞ 17 x 30	5	5,000 / 7,500	5,000 / 7,500	—	—	PC	PC	29
Ⓞ 17 x 30	22	22,500 / 33,750	8,000 / 12,000	15,000 / 22,500	22,500 / 33,750	PD	PG	30 - 31
Ⓞ 17 x 30	22	22,500 / 33,750	8,000 / 12,000	15,000 / 22,500	22,500 / 33,750	PG	PG	30 - 31
Ⓞ 17 x 30	15	15,000 / 22,500	8,000 / 12,000	15,000 / 22,500	—	PT	PG	32

LARGE ENCLOSURES

Ⓞ 24 x 24	22	15,000 / 22,500	8,000 / 12,000	15,000 / 22,500	22,500 / 33,750	PG	PG	33
Ⓞ 24 x 36	22	22,500 / 33,750	8,000 / 12,000	15,000 / 22,500	22,500 / 33,750	PG	PG	34 - 35
Ⓞ 24 x 36	22	22,500 / 33,750	8,000 / 12,000	15,000 / 22,500	22,500 / 33,750	PD	PG	34 - 35
Ⓞ 30 x 48	22	22,500 / 33,750	8,000 / 12,000	15,000 / 22,500	22,500 / 33,750	PG	PG	36 - 37
Ⓞ 30 x 48	22	22,500 / 33,750	8,000 / 12,000	15,000 / 22,500	22,500 / 33,750	PD	PG	36 - 37
30 x 60	22	22,500 / 33,750	5,000 / 7,500	15,000 / 22,500	22,500 / 33,750	PG	LG / PG	38
Ⓞ 36 x 36	22	22,500 / 33,750	8,000 / 12,000	15,000 / 22,500	22,500 / 33,750	PG	PG	39
36 x 60	22	22,500 / 33,750	5,000 / 7,500	15,000 / 22,500	22,500 / 33,750	PG	LG / PG	40
36 x 72	22	22,500 / 33,750	5,000 / 7,500	15,000 / 22,500	22,500 / 33,750	PG	LG / PG	41
48 x 48	22	22,500 / 33,750	5,000 / 7,500	15,000 / 22,500	22,500 / 33,750	PG	LG / PG	42
48 x 72	22	22,500 / 33,750	5,000 / 7,500	15,000 / 22,500	22,500 / 33,750	PG	LG / PG	43
48 x 96	22	22,500 / 33,750	5,000 / 7,500	15,000 / 22,500	22,500 / 33,750	PG	LG / PG	44

ROUND ENCLOSURES

Ⓞ 27" Dia.	22	22,500 / 33,750	8,000 / 12,000	15,000 / 22,500	22,500 / 33,750	PR	PR	46 - 47
Ⓞ 39" Dia.	22	22,500 / 33,750	5,000 / 7,500	15,000 / 22,500	22,500 / 33,750	PR	PR	48 - 49

* Loadings comply with ANSI/SCTE 77 (see page 9).

EXTENSIONS

PG1324	Pg. 25 - 26
PG1730	Pg. 30 - 31
PG2424	Pg. 33
PG2436	Pg. 34 - 35
PG3048	Pg. 36 - 37
PD3048	Pg. 33 - 37
PG3636	Pg. 39
PG3660	Pg. 40
PG4872	Pg. 43
PG4896	Pg. 44
Grade adjustable extensions	Pg. 45

REPLACEMENT COVERS

Pgs. 50 - 52

METER READING COVERS & LIDS

Pg. 53



SPECIFICATIONS/DATA

6" x 8" PC Style (Stackable) Assembly

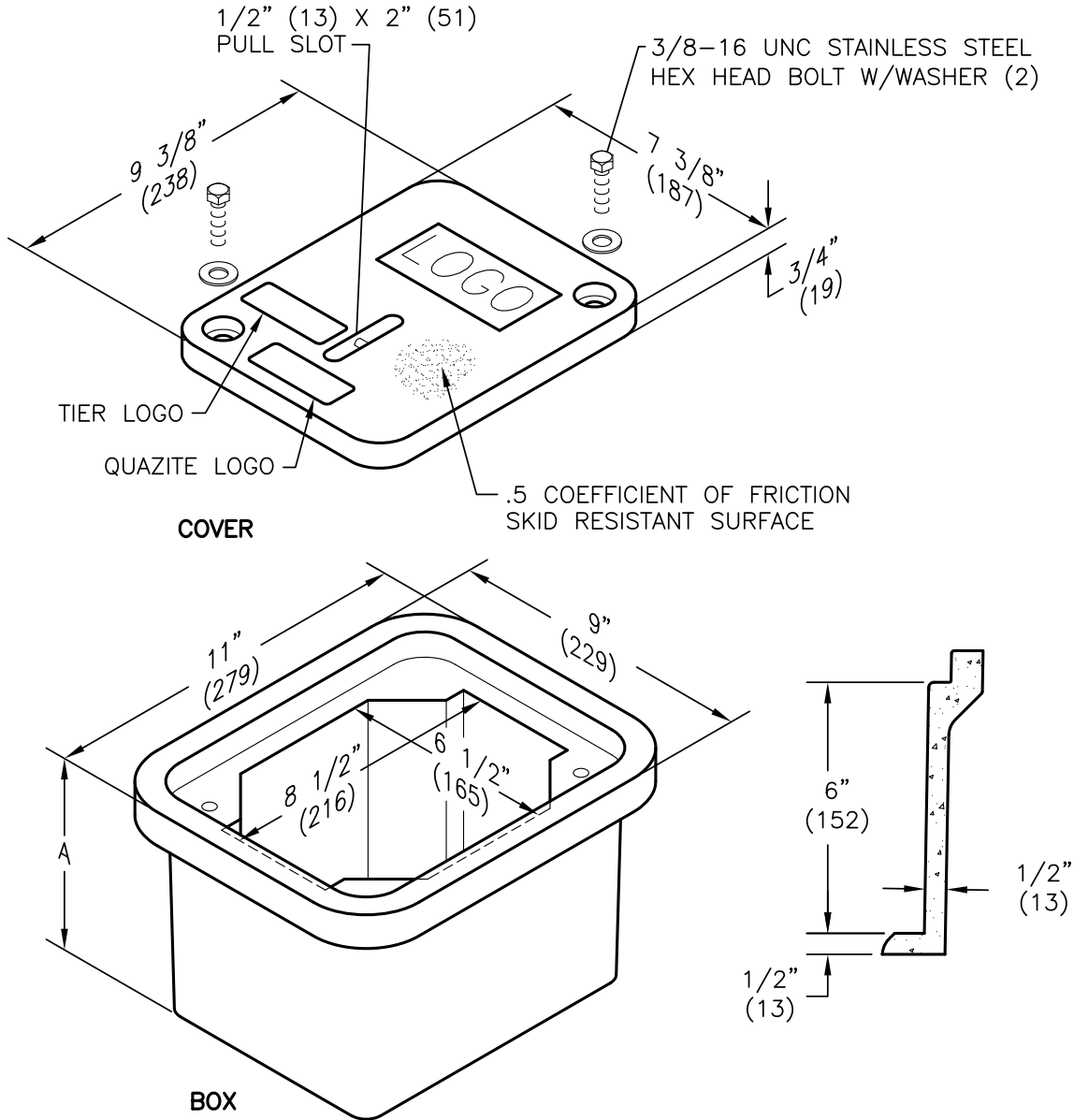

ENCLOSURE DRAWINGS

Covers (Blank unless logo is specified)

DESCRIPTION	PART NO.	WEIGHT #	DESIGN/TEST LOAD #	ANSI TIER*
W/2 Bolts	PC0608HA00	4 (1.8 kg)	15,000 / 22,500	15
Gasketed w/4 Bolts	PC0608HG00	4 (1.8 kg)	15,000 / 22,500	15

* Gasketed covers and bolt grommets must be used with a gasketed box. Gaskets reduce the inflow of fluids but do not make the enclosure water tight.

Boxes (Stackable with self-aligning, replaceable EZ-Nut)

DESCRIPTION	PART NO.	WEIGHT #	DIMENSION A	DESIGN/TEST LOAD #	ANSI TIER*
Open Bottom	PC0608BA06	14 (6.4 kg)	6 3/4" (171 mm)	15,000 / 22,500	15
Open Bottom w/Gasket	PC0608BG06	14 (6.4 kg)	6 3/4" (171 mm)	15,000 / 22,500	15
Solid Bottom	PC0608DA06	15 (6.8 kg)	7 1/4" (184 mm)	15,000 / 22,500	15
Solid Bottom w/Gasket	PC0608DG06	15 (6.8 kg)	7 1/4" (184 mm)	15,000 / 22,500	15

Dimensions & weights in parentheses are metric equivalent.
 * Loadings comply with ANSI/SCTE 77 (see page 9).

JANUARY 2011



SPECIFICATIONS/DATA

8" x 8" PC Style (Stackable) Assembly

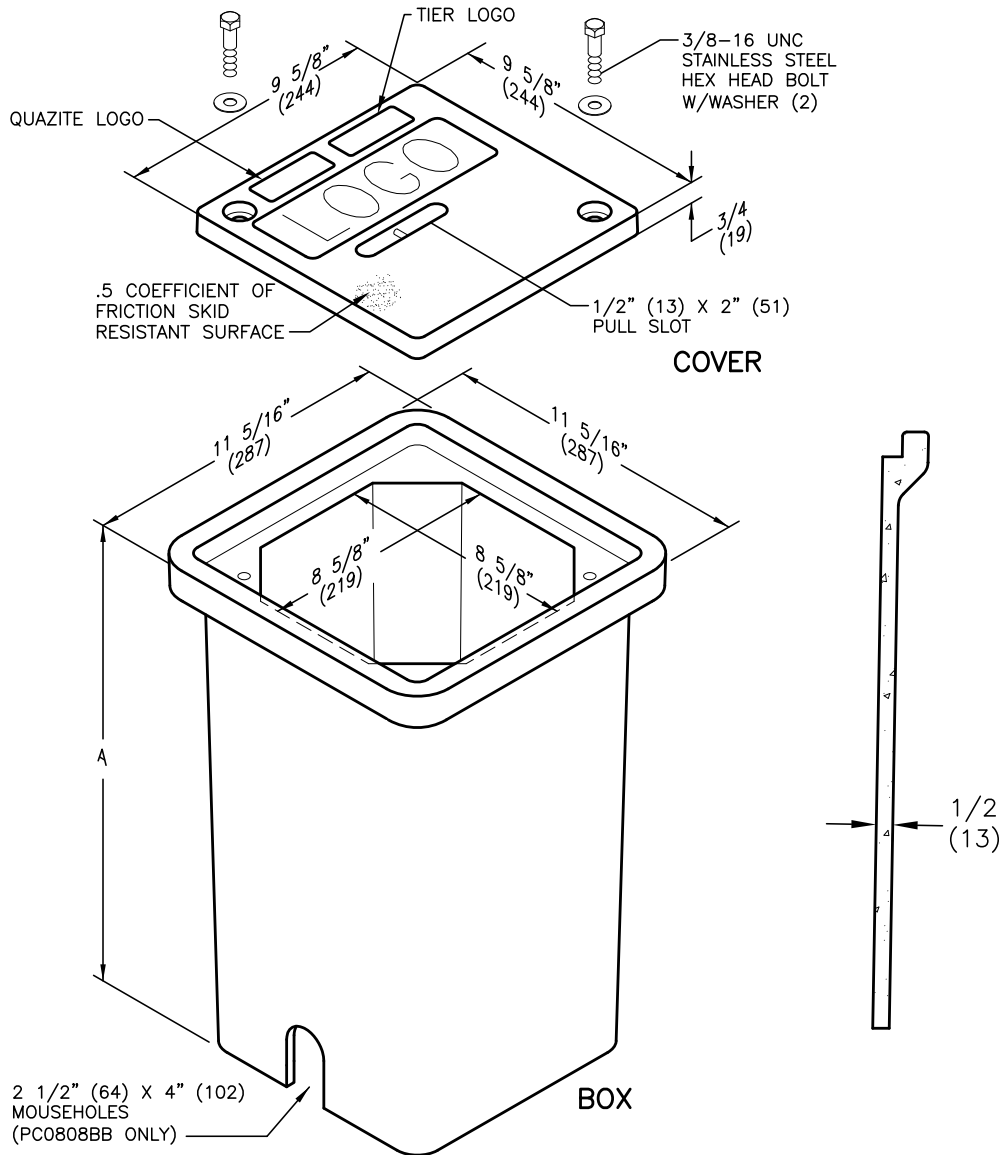

ENCLOSURE DRAWINGS

Covers (Blank unless logo is specified)

DESCRIPTION	PART NO.	WEIGHT #	DESIGN/TEST LOAD #	ANSI TIER*
W/2 Bolts	PC0808HA00	6 (3 kg)	15,000 / 22,500	15
	PC0808HG00	6 (3 kg)	15,000 / 22,500	15
	PC0808HH00	6 (3 kg)	22,500 / 33,750	22

Boxes (With self-aligning, replaceable EZ-Nut)

DESCRIPTION	PART NO.	WEIGHT #	DIMENSION A	DESIGN/TEST LOAD #	ANSI TIER*
Open Bottom	PC0808BA12	25 (11 kg)	12" (304 mm)	22,500 / 33,750	22
	PC0808BA18	36 (16 kg)	18" (457 mm)	22,500 / 33,750	22
Open Bottom w/2 Mouseholes	PC0808BB12	23 (10 kg)	12" (304 mm)	22,500 / 33,750	22
	PC0808BB18	34 (15 kg)	18" (457 mm)	22,500 / 33,750	22
Open Bottom w/Gasket	PC0808BG12	25 (11 kg)	12" (304 mm)	22,500 / 33,750	22
	PC0808BG18	34 (15 kg)	18" (457 mm)	22,500 / 33,750	22
Solid Bottom	PC0808DA18	42 (19 kg)	18 1/2" (470 mm)	22,500 / 33,750	22
Solid Bottom w/Gasket	PC0808DG18	42 (19 kg)	18 1/2" (470 mm)	22,500 / 33,750	22

Dimensions & weights in parentheses are metric equivalent.
For gasketed enclosure, see Options Section.

* Loadings comply with ANSI/SCTE 77 (see page 9).



SPECIFICATIONS/DATA

8" x 18" PC Style (Stackable) Assembly

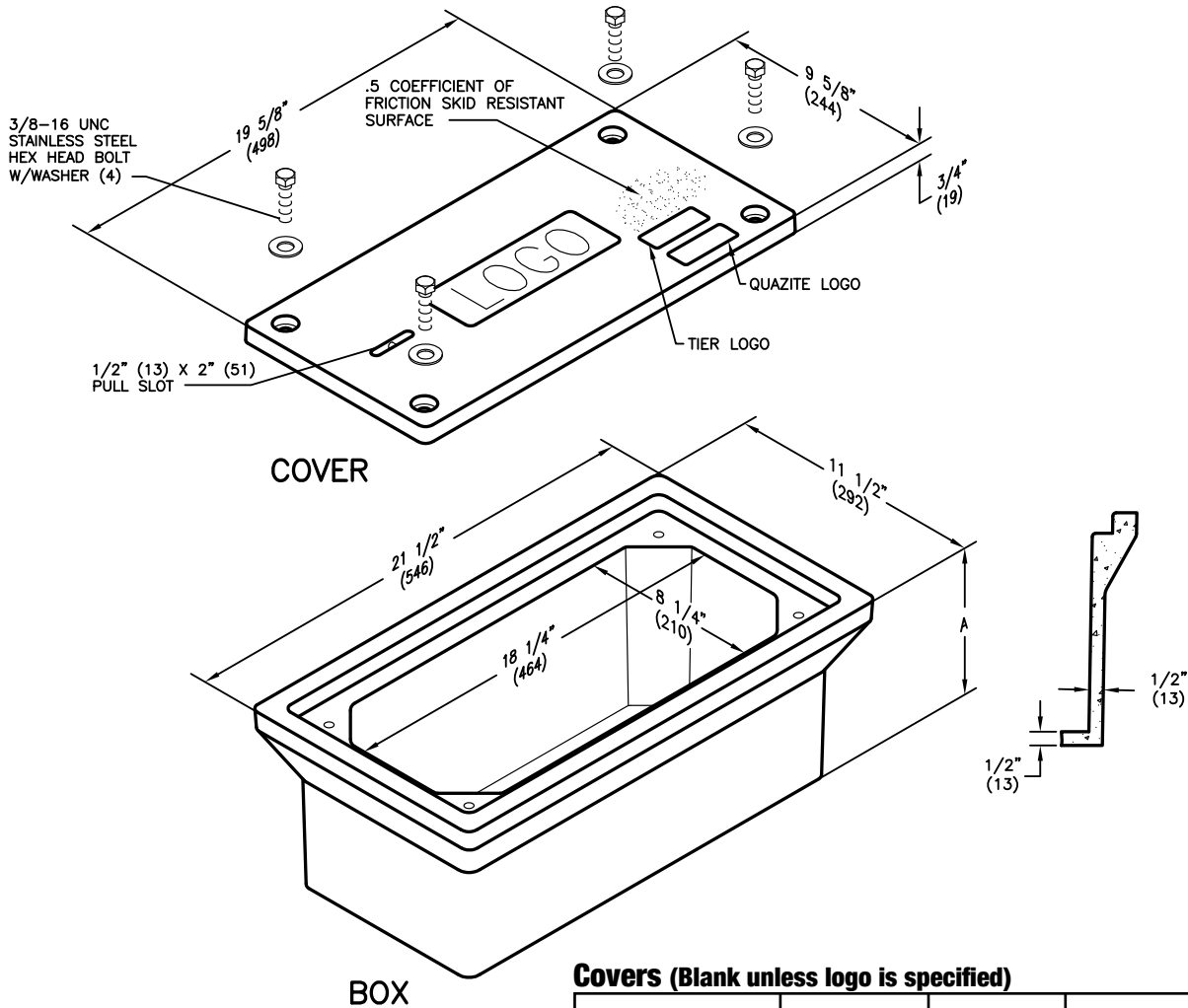

ENCLOSURE DRAWINGS

Covers (Blank unless logo is specified)

	DESCRIPTION	PART NO.	WEIGHT #	DESIGN/TEST LOAD #	ANSI TIER*
Ⓛ	W/4 Bolts	PC0818CA00	11 (5.0 kg)	8,000 / 12,000	8
Ⓛ	Gasketed w/4 Bolts	PC0818CG00	11 (5.0 kg)	8,000 / 12,000	8
Ⓛ	No Bolts	PC0818WA00	11 (5.0 kg)	8,000 / 12,000	8
Ⓛ	Heavy Duty w/4 Bolts	PC0818HA00	11 (5.0 kg)	15,000 / 22,500	15
Ⓛ	Gasketed Heavy Duty w/4 Bolts	PC0818HG00	11 (5.0 kg)	15,000 / 22,500	15

* Gasketed covers and bolt grommets must be used with a gasketed box. Gaskets reduce the inflow of fluids but do not make the enclosure water tight.

Boxes (Stackable with self-aligning, replaceable EZ-Nut)

	DESCRIPTION	PART NO.	WEIGHT #	DIMENSION A	DESIGN/TEST LOAD #	ANSI TIER*
Ⓛ	Open Bottom	PC0818BA07	25 (11 kg)	7" (178 mm)	15,000 / 22,500	15
		PC0818BA08	27 (12.2 kg)	8" (203 mm)	15,000 / 22,500	15
Ⓛ	Open Bottom w/ Gasket	PC0818BG07	25 (11 kg)	7" (178 mm)	15,000 / 22,500	15
		PC0818BG08	27 (12.2 kg)	8" (203 mm)	15,000 / 22,500	15
Ⓛ	Solid Bottom	PC0818DA07	32 (14.5 kg)	7 1/2" (191 mm)	15,000 / 22,500	15
		PC0818DA08	35 (15.9 kg)	8 1/2" (216 mm)	15,000 / 22,500	15
Ⓛ	Solid Bottom w/ Gasket	PC0818DG07	32 (14.5 kg)	7 1/2" (191 mm)	15,000 / 22,500	15
		PC0818DG08	35 (15.9 kg)	8 1/2" (216 mm)	15,000 / 22,500	15

Dimensions & weights in parentheses are metric equivalent.

* Loadings comply with ANSI/SCTE 77 (see page 9).

SPECIFICATIONS/DATA

10" x 15" PT Style (Nestable) Assembly

Covers (Blank unless logo is specified)

DESCRIPTION	PART NO.	WEIGHT #	DESIGN/ TEST LOAD #	ANSI TIER*
W/2 Bolts	PG1015CA00	20 (9.0 kg)	8,000 / 12,000	8
Gasketed w/2 Bolts	PG1015CG00	20 (9.0 kg)	8,000 / 12,000	8
No Bolts	PG1015WA00	20 (9.0 kg)	8,000 / 12,000	8
Heavy Duty w/2 Bolts	PG1015HA00	20 (9.0 kg)	15,000 / 22,500	15
Gasketed Heavy Duty w/2 Bolts	PG1015HG00	20 (9.0 kg)	15,000 / 22,500	15

* Gasketed covers and bolt grommets must be used with a gasketed box. Gaskets reduce the inflow of fluids but do not make the enclosure water tight.

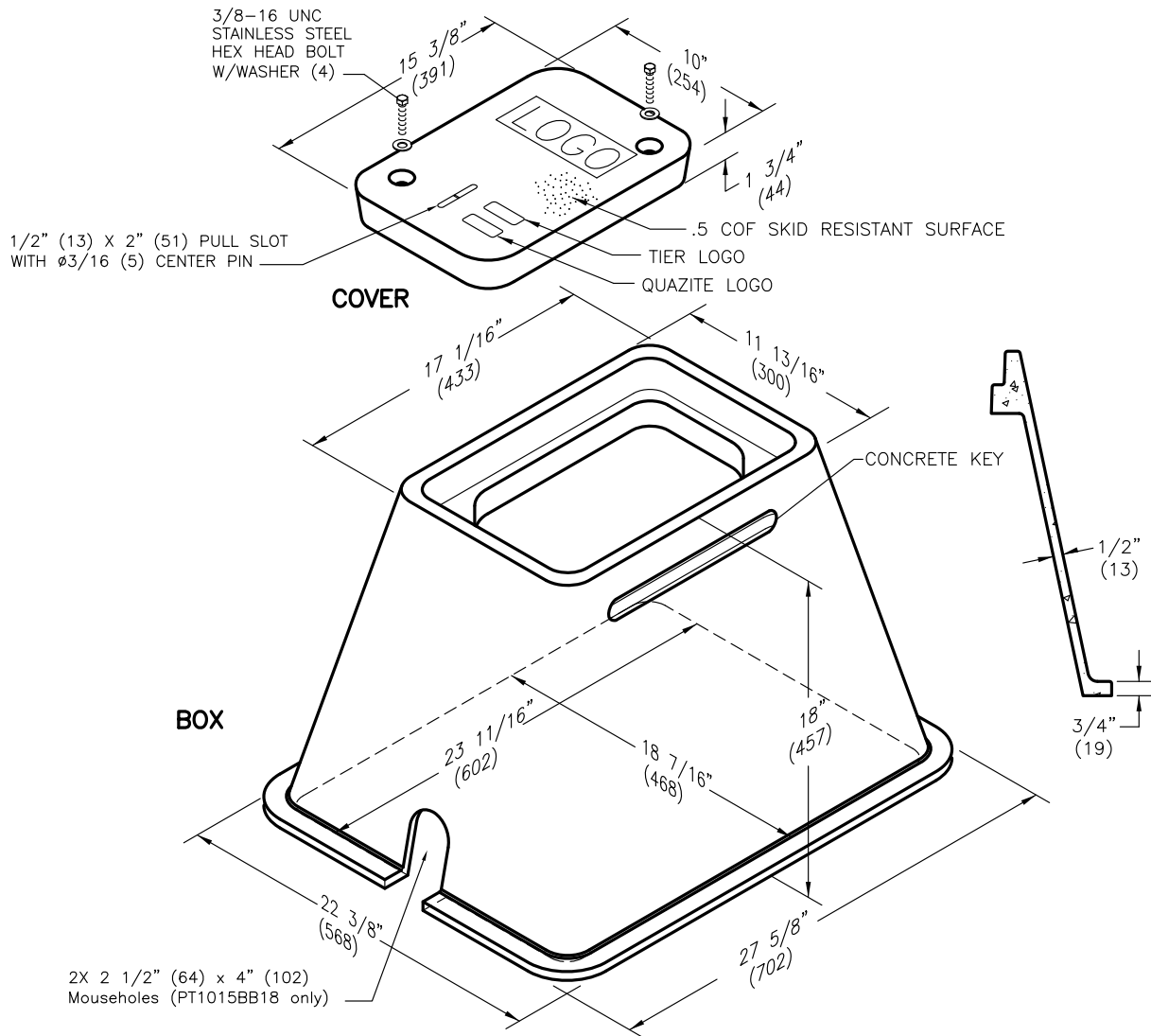

ENCLOSURE DRAWINGS

BOXES (Nestable with self-aligning, replaceable EZ-Nut)

DESCRIPTION	PART NO.	WEIGHT #	DESIGN/TEST LOAD #	ANSI TIER*
Open Bottom	PT1015BA18	70 (32.0 kg)	15,000 / 22,500	15
Open Bottom w/Gasket	PT1015BG18	70 (32.0 kg)	15,000 / 22,500	15
Open Bottom w/2 Mouseholes	PT1015BB18	69 (31.0 kg)	15,000 / 22,500	15

Dimensions & weights in parentheses are metric equivalent.
* Loadings comply with ANSI/SCTE 77 (see page 9).



SPECIFICATIONS/DATA

11" x 18" PG Style (Stackable) Assembly

Covers (Blank unless logo is specified)

DESCRIPTION	PART NO.	WEIGHT #	DESIGN/TEST LOAD #	ANSI TIER*
Ⓛ W/2 Bolts	PG1118CA00	27 (12.2 kg)	8,000 / 12,000	8
Ⓛ Gasketed w/2 Bolts	PG1118CG00	27 (12.2 kg)	8,000 / 12,000	8
Ⓛ No Bolts	PG1118WA00	27 (12.2 kg)	8,000 / 12,000	8
Ⓛ Heavy Duty w/2 Bolts	PG1118HA00	27 (12.2 kg)	15,000 / 22,500	15
Ⓛ Gasketed Heavy Duty w/2 Bolts	PG1118HG00	27 (12.2 kg)	15,000 / 22,500	15
Ⓛ Extra Heavy Duty w/2 Bolts	PG1118HH00	27 (12.2 kg)	22,500 / 33,750	22

- Covers with meter lids available upon request. See page 12 or page 57 for meter lid cover load rating explanation.
- Gasketed covers and bolt grommets must be used with a gasketed box. Gaskets reduce the inflow of fluids but do not make the enclosure water tight.

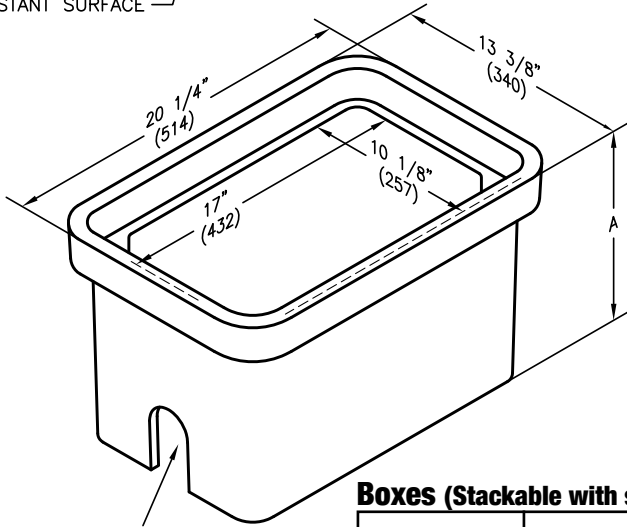
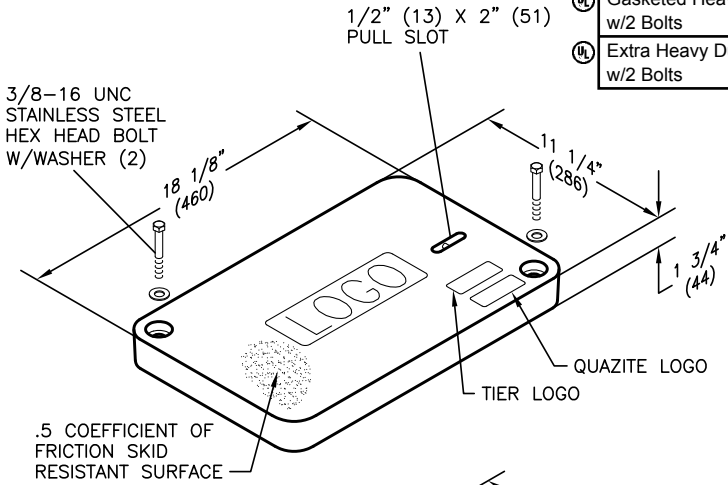

2X 2 1/2" (64) X 4" (102) MOUSEHOLES (PG1118BB only)

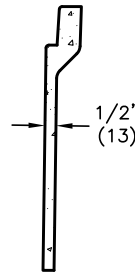

Boxes (Stackable with self-aligning, replaceable EZ-Nut)

DESCRIPTION	PART NO.	WEIGHT #	DIMENSION A	DESIGN/TEST LOAD #	ANSI TIER*
Ⓛ Open Bottom	PG1118BA12	40 (18 kg)	12" (305 mm)	22,500 / 33,750	22
	PG1118BA18	53 (24 kg)	18" (457 mm)	22,500 / 33,750	22
Ⓛ Open Bottom w/ Gasket	PG1118BG12	40 (18 kg)	12" (305 mm)	22,500 / 33,750	22
	PG1118BG18	53 (24 kg)	18" (457 mm)	22,500 / 33,750	22
Ⓛ Open Bottom w/ 2 Mouseholes	PG1118BB12	40 (18 kg)	12" (305 mm)	22,500 / 33,750	22
	PG1118BB18	53 (24 kg)	18" (457 mm)	22,500 / 33,750	22
Ⓛ Solid Bottom	PG1118DA12	43 (19.5 kg)	12 1/2" (318 mm)	22,500 / 33,750	22
	PG1118DA18	60 (27 kg)	18 1/2" (470 mm)	22,500 / 33,750	22
Ⓛ Solid Bottom w/ Gasket	PG1118DG12	43 (19.5 kg)	12 1/2" (318 mm)	22,500 / 33,750	22
	PG1118DG18	60 (27 kg)	18 1/2" (470 mm)	22,500 / 33,750	22
Ⓛ Footed Box	PG1118JA12	41 (19 kg)	12 1/2" (318 mm)	22,500 / 33,750	22
	PG1118JA18	55 (25 kg)	18 1/2" (470 mm)	22,500 / 33,750	22

Dimensions & weights in parentheses are metric equivalent.
 * Loadings comply with ANSI/SCTE 77 (see page 9).

ENCLOSURE DRAWINGS

SPECIFICATIONS/DATA

11" x 18" PC Style (Stackable) Assembly

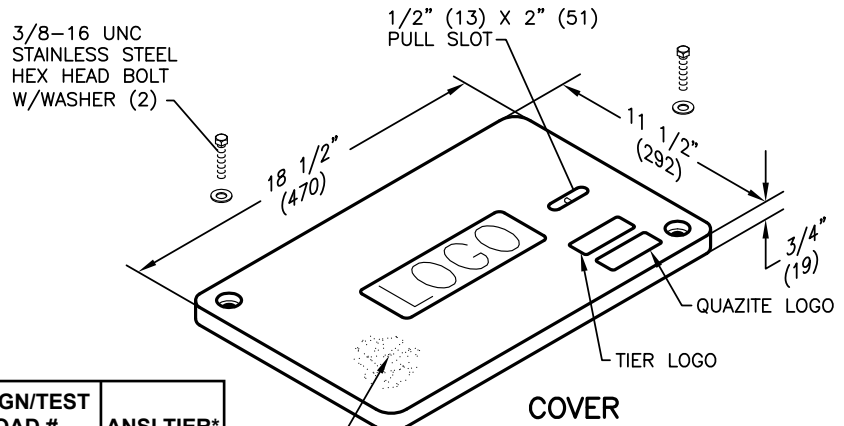

Covers (Blank unless logo is specified)

	DESCRIPTION	PART NO.	WEIGHT #	DESIGN/TEST LOAD #	ANSI TIER*
Ⓞ	W/2 Bolts	PC1118CA00	13 (5.9 kg)	8,000 / 12,000	8
Ⓞ	Gasketed w/4 Bolts	PC1118CG00	13 (5.9 kg)	8,000 / 12,000	8
Ⓞ	No Bolts	PC1118WA00	13 (5.9 kg)	8,000 / 12,000	8

* Gasketed covers and bolt grommets must be used with a gasketed box. Gaskets reduce the inflow of fluids but do not make the enclosure water tight.

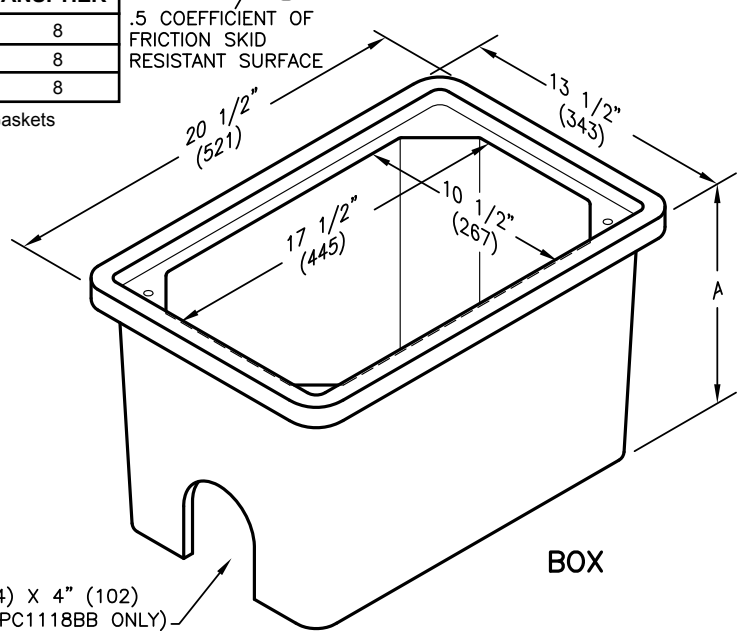
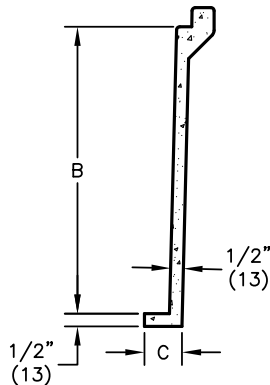

Boxes (Stackable with self-aligning, replaceable EZ-Nut)

	DESCRIPTION	PART NO.	WEIGHT #	DIMENSION A	DIMENSION B	DIMENSION C	DESIGN/TEST LOAD #	ANSI TIER*
Ⓞ	Open Bottom	PC1118BA12	37 (16.8 kg)	12" (304.8 mm)	11 1/4" (286 mm)	N/A	8,000 / 12,000	8
		PC1118BA18	53 (24.0 kg)	18" (457 mm)	17 1/4" (438 mm)	N/A	8,000 / 12,000	8
Ⓞ	Open Bottom w/ Gasket	PC1118BG12	37 (16.8 kg)	12" (304.8 mm)	11 1/4" (286 mm)	N/A	8,000 / 12,000	8
		PC1118BG18	53 (24.0 kg)	18" (457 mm)	17 1/4" (438 mm)	N/A	8,000 / 12,000	8
Ⓞ	Open Bottom w/ 2 Mouseholes	PC1118BB12	36 (16.3 kg)	12" (304.8 mm)	11 1/4" (286 mm)	N/A	8,000 / 12,000	8
		PC1118BB18	52 (23.6 kg)	18" (457 mm)	17 1/4" (438 mm)	N/A	8,000 / 12,000	8
Ⓞ	Solid Bottom	PC1118DA12	45 (20.4 kg)	12 1/2" (317.5 mm)	11 1/4" (286 mm)	N/A	8,000 / 12,000	8
		PC1118DA18	60 (27.2 kg)	18 1/2" (470 mm)	17 1/4" (438 mm)	N/A	8,000 / 12,000	8
Ⓞ	Solid Bottom w/ Gasket	PC1118DG12	45 (20.4 kg)	12 1/2" (317.5 mm)	11 1/4" (286 mm)	N/A	8,000 / 12,000	8
		PC1118DG18	60 (27.2 kg)	18 1/2" (470 mm)	17 1/4" (438 mm)	N/A	8,000 / 12,000	8
Ⓞ	Footed Box	PC1118JA12	37 (16.8 kg)	12 1/2" (317.5 mm)	11 1/4" (286 mm)	1 1/2" (38 mm)	8,000 / 12,000	8
		PC1118JA18	56 (25.4 kg)	18 1/2" (470 mm)	17 1/4" (438 mm)	1 1/2" (38 mm)	8,000 / 12,000	8

Dimensions & weights in parentheses are metric equivalent.

* Loadings comply with ANSI/SCTE 77 (see page 9).



SPECIFICATIONS/DATA

11" x 20" PG Style (Stackable) Assembly

Covers (Blank unless logo is specified)

DESCRIPTION	PART NO.	WEIGHT #	DESIGN/TEST LOAD #	ANSI TIER*
w/2 Bolts	PG1120CA00	28 (12.7 kg)	8,000 / 12,000	8
Gasketed w/2 Bolts	PG1120CG12	28 (12.7 kg)	8,000 / 12,000	8
No Bolts	PG1120WA00	28 (12.7 kg)	8,000 / 12,000	8
Heavy Duty w/2 Bolts	PG1120HA00	38 (17.2 kg)	15,000 / 22,500	15
Gasketed Heavy Duty w/2 Bolts	PG1120HG00	38 (17.2 kg)	15,000 / 22,500	15
Extra Heavy Duty w/2 Bolts	PG1120HH00	38 (17.2 kg)	22,500 / 33,750	22

- Covers with meter lids available upon request. See page 12 or page 57 for meter lid cover load rating explanation.
- Gasketed covers and bolt grommets must be used with a gasketed box. Gaskets reduce the inflow of fluids but do not make the enclosure water tight.
- * Loadings comply with ANSI/SCTE 77 (See page 9)

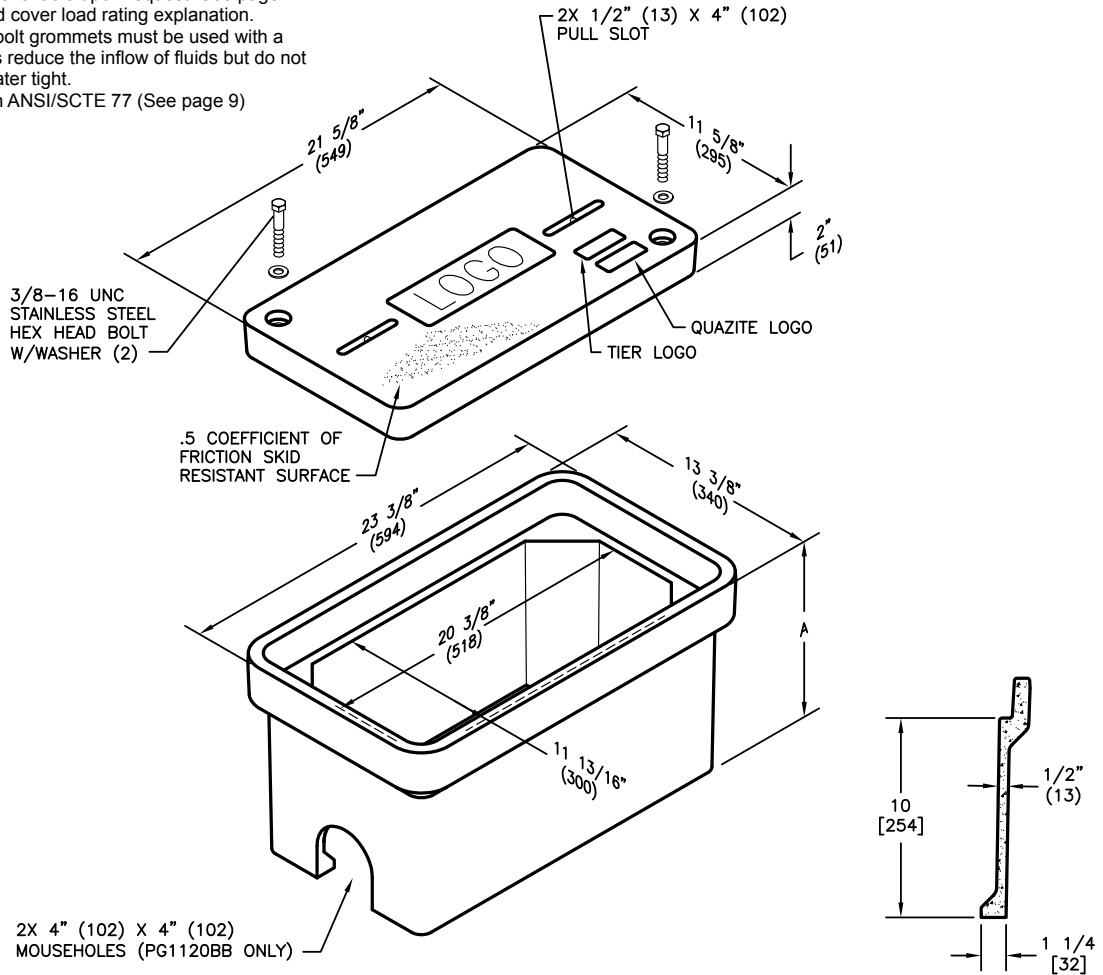

Boxes (Stackable with self-aligning, replaceable EZ-Nut)

DESCRIPTION	PART NO.	WEIGHT #	DIMENSION A	DESIGN/TEST LOAD #	ANSI TIER*
Open Bottom	PG1120BA12	12 (305 mm)	50 (22.7 kg)	22,500 / 33,750	22
Open Bottom w/Gasket	PG1120BG12	12 (305 mm)	50 (22.7 kg)	22,500 / 33,750	22
Open Bottom w/Mouseholes	PG1120BB12	12 (305 mm)	50 (22.7 kg)	22,500 / 33,750	22
Solid Bottom	PG1120DA12	12 1/2 (318 mm)	59 (26.8 kg)	22,500 / 33,750	22
Solid Bottom w/Gasket	PG1120DG12	12 1/2 (318 mm)	59 (26.8 kg)	22,500 / 33,750	22

Dimensions & weights in parentheses are metric equivalent.

* Loadings comply with ANSI/SCTE 77 (see page 9).

SPECIFICATIONS/DATA

12" x 12" PC Style (Stackable) Assembly

Covers (Blank unless logo is specified)

DESCRIPTION	PART NO.	WEIGHT #	DESIGN/TEST LOAD #	ANSI TIER*
Ⓛ W/2 Bolts	PC1212CA00	12 (5.4 kg)	8,000 / 12,000	8
Ⓛ Gasketed w/4 Bolts	PC1212CG00	12 (5.4 kg)	8,000 / 12,000	8
Ⓛ No Bolts	PC1212WA00	12 (5.4 kg)	8,000 / 12,000	8
Ⓛ Heavy Duty w/2 Bolts	PC1212HA00	12 (5.4 kg)	15,000 / 22,500	15
Ⓛ Gasketed Heavy Duty w/4 Bolts	PC1212HG00	12 (5.4 kg)	15,000 / 22,500	15

• Gasketed covers and bolt grommets must be used with a gasketed box. Gaskets reduce the inflow of fluids but do not make the enclosure water tight.

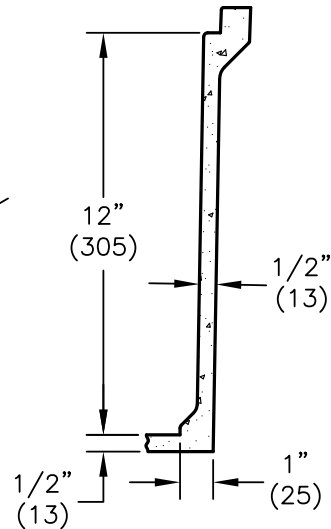
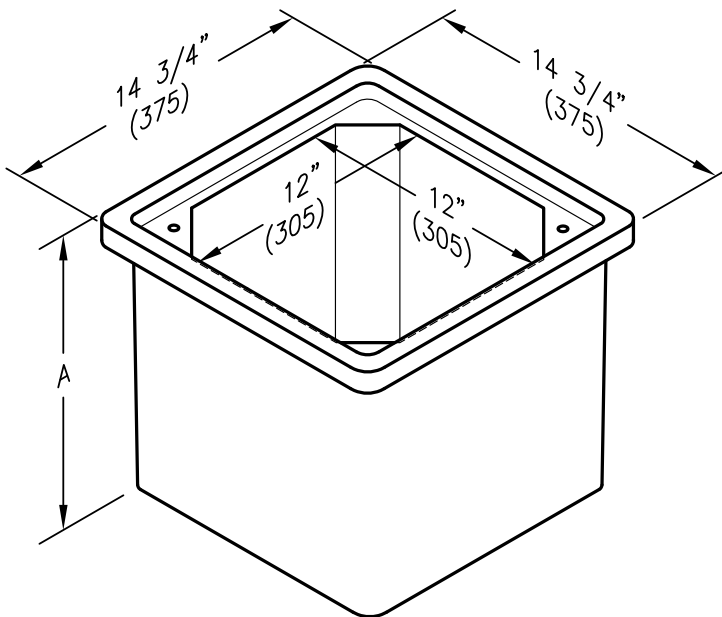
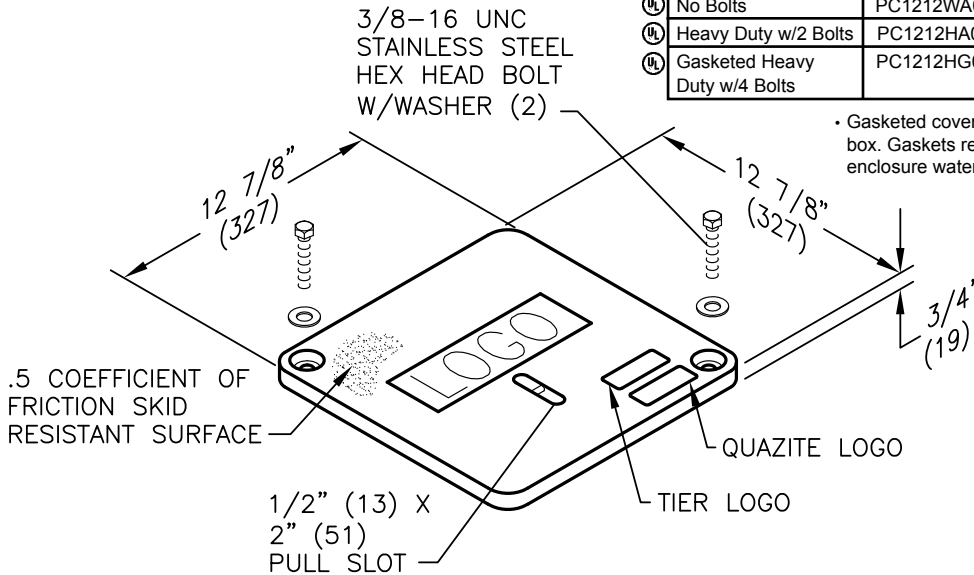

Boxes (Stackable with self-aligning, replaceable EZ-Nut)

DESCRIPTION	PART NO.	WEIGHT #	DIMENSION A	DESIGN/TEST LOAD #	ANSI TIER*
Ⓛ Open Bottom	PC1212BA12	36 (16 kg)	12 3/4" (324 mm)	15,000 / 22,500	15
Ⓛ Open Bottom w/Gasket	PC1212BG12	36 (16 kg)	12 3/4" (324 mm)	15,000 / 22,500	15
Ⓛ Solid Bottom	PC1212DA12	41 (19 kg)	13 1/4" (337 mm)	15,000 / 22,500	15
Ⓛ Solid Bottom w/Gasket	PC1212DG12	41 (19 kg)	13 1/4" (337 mm)	15,000 / 22,500	15

Dimensions & weights in parentheses are metric equivalent.

* Loadings comply with ANSI/SCTE 77 (see page 9).



SPECIFICATIONS/DATA

12" x 12" PX Style (Nestable) Assembly

Covers (Blank unless logo is specified)

DESCRIPTION	PART NO.	WEIGHT #	DESIGN/TEST LOAD #	ANSI TIER*
Ⓛ W/2 Bolts	PC1212CA00	12 (5.4 kg)	8,000 / 12,000	8
Ⓛ Gasketed w/4 Bolts	PC1212CG00	12 (5.4 kg)	8,000 / 12,000	8
Ⓛ No Bolts	PC1212WA00	12 (5.4 kg)	8,000 / 12,000	8
Ⓛ Heavy Duty w/2 Bolts	PC1212HA00	12 (5.4 kg)	15,000 / 22,500	15
Ⓛ Gasketed Heavy Duty w/4 Bolts	PC1212HG00	12 (5.4 kg)	15,000 / 22,500	15

• Gasketed covers and bolt grommets must be used with a gasketed box. Gaskets reduce the inflow of fluids but do not make the enclosure water tight.

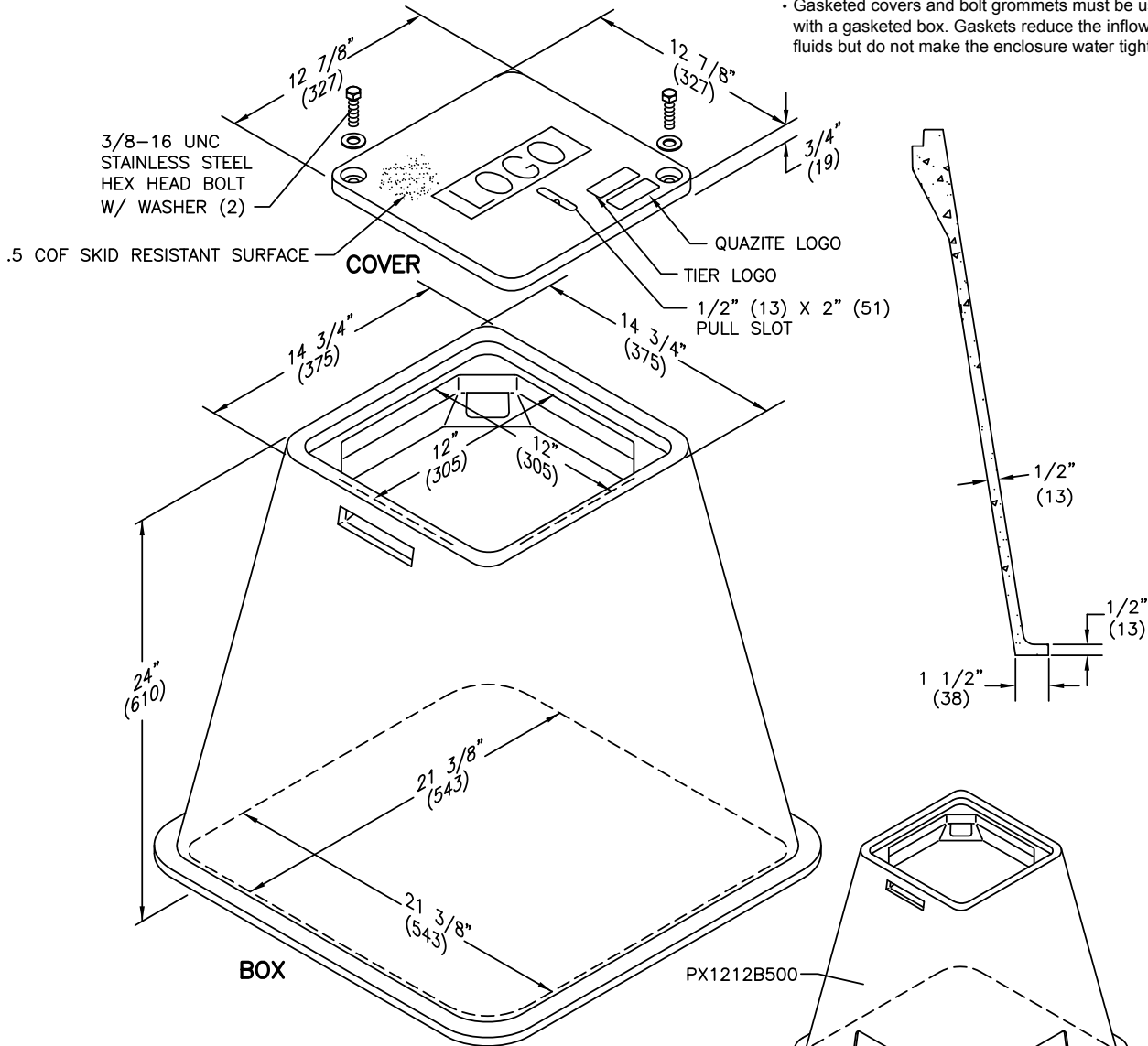

Boxes (Nestable)

DESCRIPTION	PART NO.	WEIGHT #	DESIGN/TEST LOAD #	ANSI TIER*
Open Bottom	PX1212BA24	85 (39 kg)	15,000 / 22,500	15
Open Bottom w/Gasket	PX1212BG24	85 (39 kg)	15,000 / 22,500	15
Open Bottom w/Knockouts	PX1212B500	84 (38 kg)	15,000 / 22,500	15

Dimensions & weights in parentheses are metric equivalent.

* Loadings comply with ANSI/SCTE 77 (see page 9).

SPECIFICATIONS/DATA

13" x 24" PG Style (Stackable) Assembly and 13" x 24" PD Style Assembly

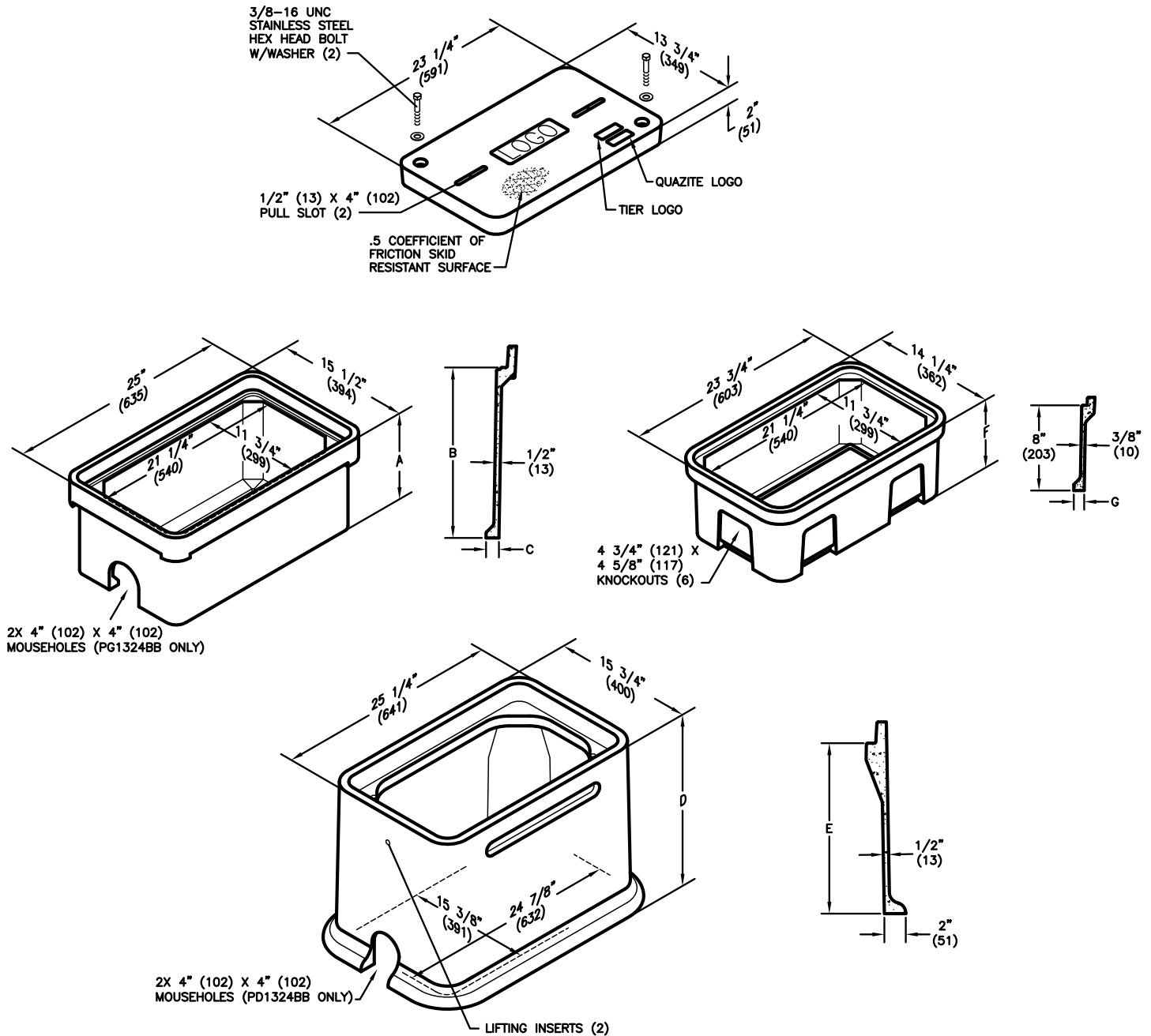

ENCLOSURE DRAWINGS



13" x 24" PG Style (Stackable) Assembly and 13" x 24" PD Style Assembly

SPECIFICATIONS/DATA

Covers (Blank unless logo is specified)

DESCRIPTION	PART NO.	WEIGHT #	DESIGN/TEST LOAD #	ANSI TIER*
W/2 Bolts	PG1324CA00	33 (15 kg)	8,000 / 12,000	8
Gasketed w/2 Bolts	PG1324CG00	33 (15 kg)	8,000 / 12,000	8
No Bolts	PG1324WA00	33 (15 kg)	8,000 / 12,000	8
Heavy Duty w/2 Bolts	PG1324HA00	51 (23 kg)	15,000 / 22,500	15
Gasketed Heavy Duty w/2 Bolts	PG1324HG00	51 (23 kg)	15,000 / 22,500	15
Extra Heavy Duty w/2 Bolts	PG1324HH00	54 (24 kg)	22,500 / 33,750	22

- Covers with meter lids available upon request. See page 12 or page 57 for meter lid cover load rating explanation.
- Gasketed covers and bolt grommets must be used with a gasketed box. Gaskets reduce the inflow of fluids but do not make the enclosure water tight.

PG Boxes (Stackable with self-aligning, replaceable EZ Nut)

DESCRIPTION	PART NO.	WEIGHT #	DIMENSION A	DIMENSION B	DIMENSION C	DESIGN/TEST LOAD #	ANSI TIER*
Open Bottom	PG1324BA12	53 (24 kg)	12" (305 mm)	10" (254 mm)	1 1/4" (32 mm)	22,500 / 33,750	22
	PG1324BA18	72 (33 kg)	18" (457 mm)	16" (406 mm)	1 1/4" (32 mm)	22,500 / 33,750	22
Open Bottom w/2 Mouseholes	PG1324BB12	49 (22.2 kg)	12" (305 mm)	10" (254 mm)	1 1/4" (32 mm)	22,500 / 33,750	22
	PG1324BB18	68 (31 kg)	18" (457 mm)	16" (406 mm)	1 1/4" (32 mm)	22,500 / 33,750	22
Solid Bottom	PG1324DA12	63 (28.6 kg)	12 1/2" (318 mm)	10" (254 mm)	N/A	22,500 / 33,750	22
	PG1324DA18	85 (39 kg)	18 1/2" (470 mm)	16" (406 mm)	N/A	22,500 / 33,750	22

PD Boxes

DESCRIPTION	PART NO.	WEIGHT #	DIMENSION D	DIMENSION E	DESIGN/TEST LOAD #	ANSI TIER*
Open Bottom	PD1324BA18	104 (47 kg)	18" (457 mm)	16" (406 mm)	22,500 / 33,750	22
	PD1324BA26	133 (60 kg)	26" (660 mm)	24" (610 mm)	22,500 / 33,750	22
Open Bottom w/2 Mouseholes	PD1324BB18	102 (46 kg)	18" (457 mm)	16" (406 mm)	22,500 / 33,750	22
	PD1324BB26	131 (59 kg)	26" (660 mm)	24" (610 mm)	22,500 / 33,750	22
Open Bottom w/Gasket	PD1324BG18	104 (47 kg)	18" (457 mm)	16" (406 mm)	22,500 / 33,750	22
	PD1324BG26	133 (60 kg)	26" (660 mm)	24" (610 mm)	22,500 / 33,750	22

Extensions (For use under box only, one per box.)

DESCRIPTION	PART NO.	WEIGHT #	DIMENSION F	DIMENSION G	DESIGN/TEST LOAD #	ANSI TIER*
Open Bottom	PG1324EA08	25 (11.3 kg)	8 3/4" (222 mm)	1" (25 mm)	22,500 / 33,750	22
Solid Bottom	PG1324RA08	35 (15.9 kg)	9 1/4" (235 mm)	N/A	22,500 / 33,750	22

Dimensions & weights in parentheses are metric equivalent.

* Loadings comply with ANSI/SCTE 77 (see page 9).

SPECIFICATIONS/DATA

13" x 24" PC Style (Stackable) Assembly

Covers (Blank unless logo is specified)

	DESCRIPTION	PART NO.	WEIGHT #	DESIGN/ TEST LOAD #	ANSI TIER*
Ⓛ	W/2 Bolts	PC1324CA00	23 (10.4 kg)	5,000 / 7,500	5
Ⓛ	Gasketed w/2 Bolts	PC1324CG00	23 (10.4 kg)	5,000 / 7,500	5
Ⓛ	No Bolts	PC1324WA00	23 (10.4 kg)	5,000 / 7,500	5

• Gasketed covers and bolt grommets must be used with a gasketed box.
Gaskets reduce the inflow of fluids but do not make the enclosure water tight.

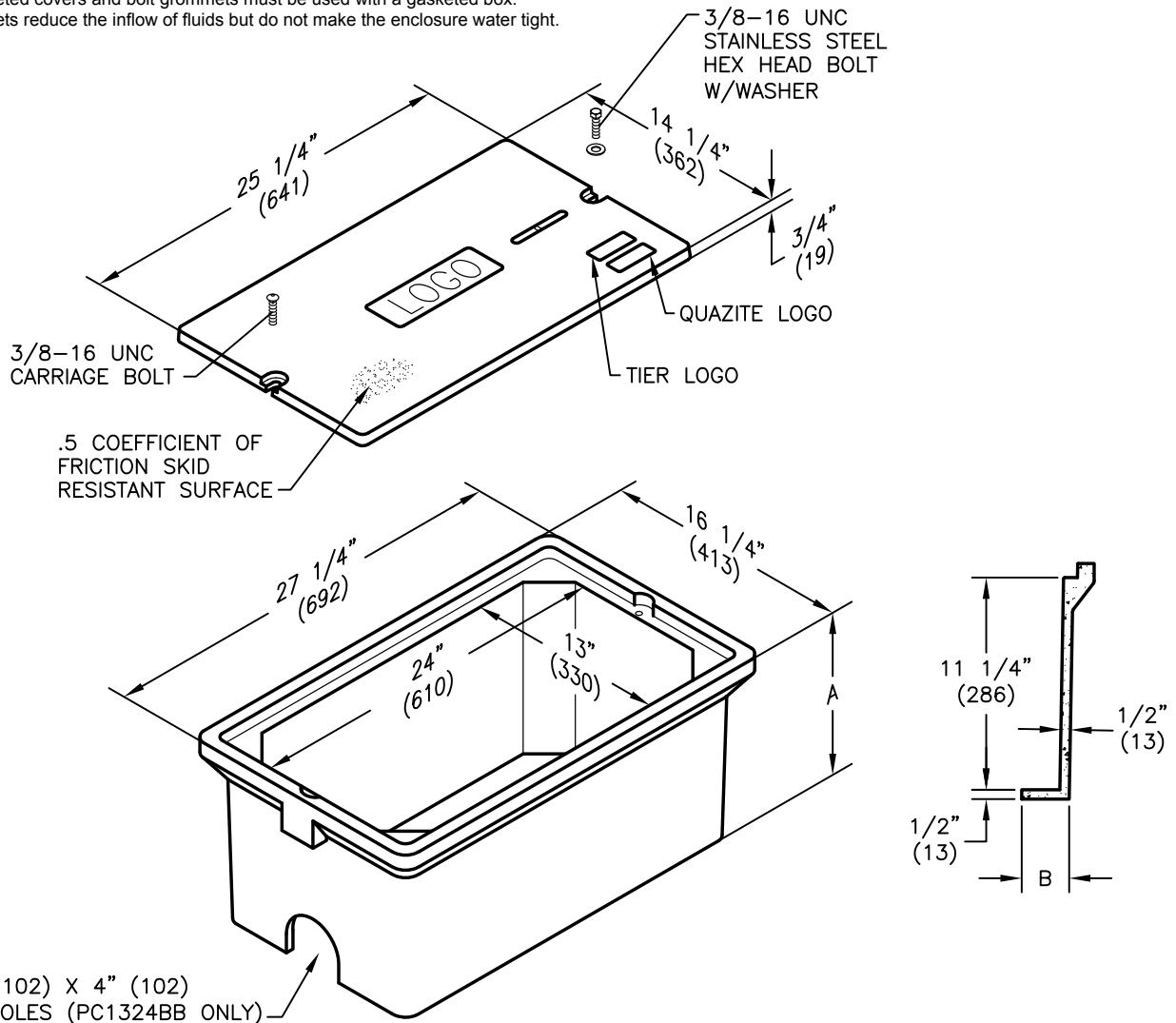

2X 4" (102) X 4" (102)
MOUSEHOLES (PC1324BB ONLY)

Boxes (Stackable with self-aligning, replaceable EZ-Nut)

	DESCRIPTION	PART NO.	WEIGHT #	DIMENSION A	DIMENSION B	DESIGN/TEST LOAD #	ANSI TIER*
Ⓛ	Open Bottom	PC1324BA12	50 (22.7 kg)	12" (305 mm)	N/A	5,000 / 7,500	5
Ⓛ	Open Bottom w/Gasket	PC1324BG12	50 (22.7 kg)	12" (305 mm)	N/A	5,000 / 7,500	5
Ⓛ	Open Bottom w/2 Mouseholes	PC1324BB12	50 (22.7 kg)	12" (305 mm)	N/A	5,000 / 7,500	5
Ⓛ	Solid Bottom	PC1324DA12	60 (27.2 kg)	12 1/2" (318 mm)	N/A	5,000 / 7,500	5
Ⓛ	Solid Bottom w/Gasket	PC1324DG12	60 (27.2 kg)	12 1/2" (318 mm)	N/A	5,000 / 7,500	5
Ⓛ	Footed Box	PC1324JA12	57 (25.9 kg)	12 1/2" (318 mm)	2 7/8" (73 mm)	5,000 / 7,500	5

Dimensions & weights in parentheses are metric equivalent.

* Loadings comply with ANSI/SCTE 77 (see page 9).



SPECIFICATIONS/DATA

13" x 24" PT Style (Nestable) Assembly

Covers (Blank unless logo is specified)

DESCRIPTION	PART NO.	WEIGHT #	DESIGN/TEST LOAD #	ANSI TIER*
Ⓛ W/2 Bolts	PT1324CA00	32 (14.5 kg)	8,000 / 12,000	8
Ⓛ Gasketed w/2 Bolts	PT1324CG00	32 (14.5 kg)	8,000 / 12,000	8
Ⓛ No Bolts	PT1324WA00	32 (14.5 kg)	8,000 / 12,000	8
Ⓛ Heavy Duty w/2 Bolts	PT1324HA00	49 (22.2 kg)	15,000 / 22,500	15
Ⓛ Gasketed Heavy Duty w/2 Bolts	PT1324HG00	49 (22.2 kg)	15,000 / 22,500	15

3/8-16 UNC
STAINLESS STEEL
HEX HEAD BOLT
W/ WASHER (2)

- Covers with meter lids available upon request. See page 12 or page 57 for meter lid cover load rating explanation.
- PT covers are PG covers with shorter bolts.
- Gasketed covers and bolt grommets must be used with a gasketed box. Gaskets reduce the inflow of fluids but do not make the enclosure water tight.

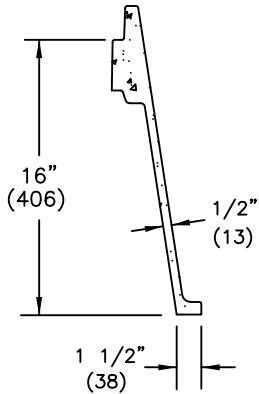
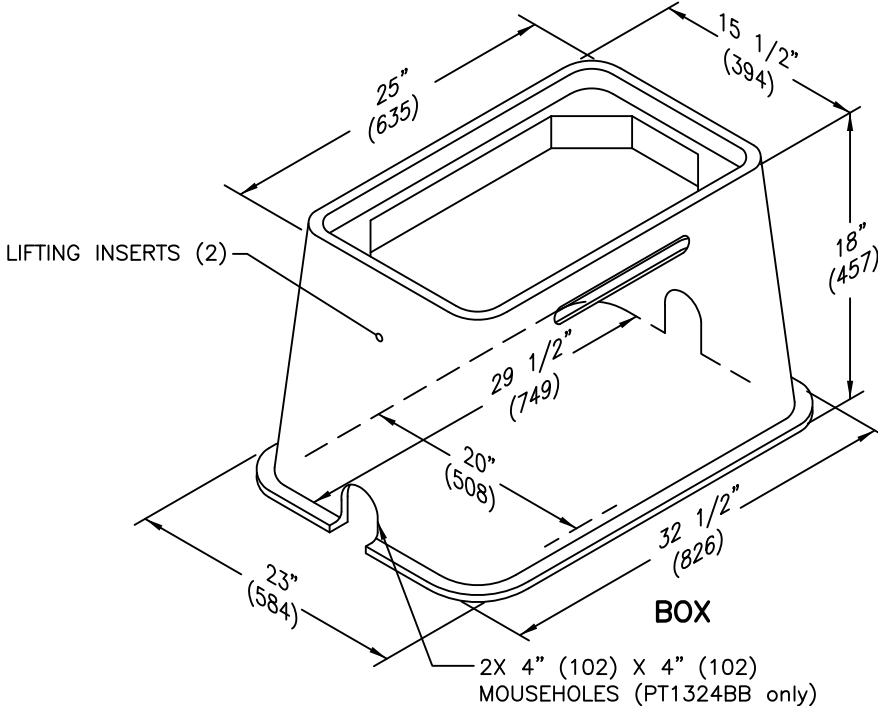
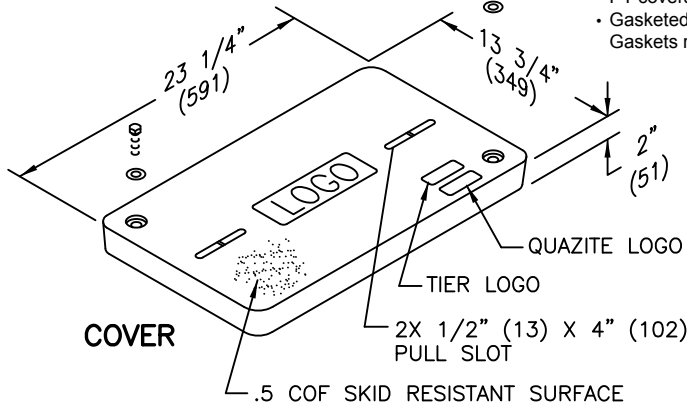

Boxes (Nestable)

DESCRIPTION	PART NO.	WEIGHT #	DESIGN/TEST LOAD #	ANSI TIER*
Ⓛ Open Bottom	PT1324BA18	97 (44.0 kg)	15,000 / 22,500	15
Ⓛ Open Bottom w/Gasket	PT1324BG18	97 (44.0 kg)	15,000 / 22,500	15
Ⓛ Open Bottom w/2 Mouseholes	PT1324BB18	96 (43.5 kg)	15,000 / 22,500	15

Dimensions & weights in parentheses are metric equivalent.
* Loadings comply with ANSI/SCTE 77 (see page 9).



SPECIFICATIONS/DATA

17" x 30" PC Style (Stackable) Assembly

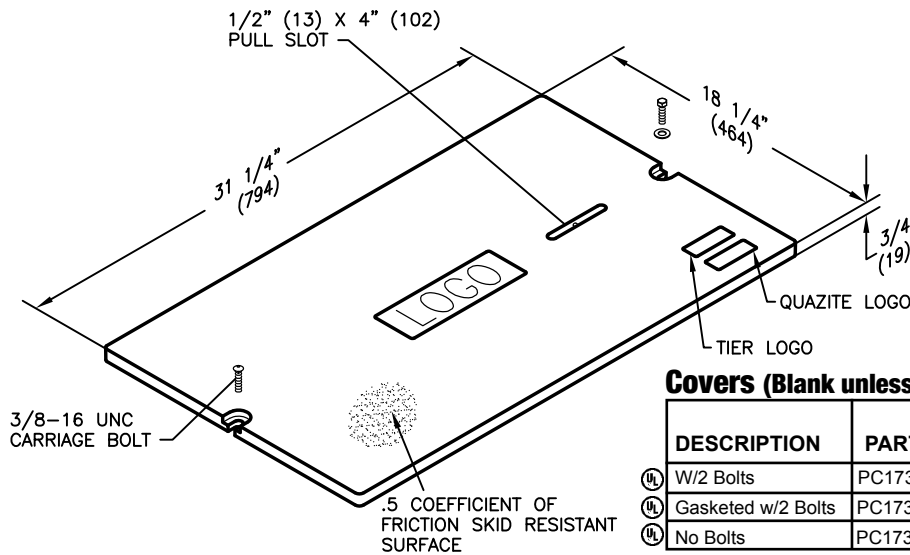

Covers (Blank unless logo is specified)

	DESCRIPTION	PART NO.	WEIGHT #	DESIGN/TEST LOAD #	ANSI TIER*
Ⓛ	W/2 Bolts	PC1730CA00	33 (15.0 kg)	5,000 / 7,500	5
Ⓛ	Gasketed w/2 Bolts	PC1730CG00	33 (15.0 kg)	5,000 / 7,500	5
Ⓛ	No Bolts	PC1730WA00	33 (15.0 kg)	5,000 / 7,500	5

* Gasketed covers and bolt grommets must be used with a gasketed box. Gaskets reduce the inflow of fluids but do not make the enclosure watertight.

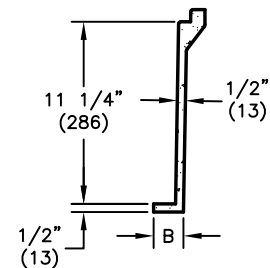
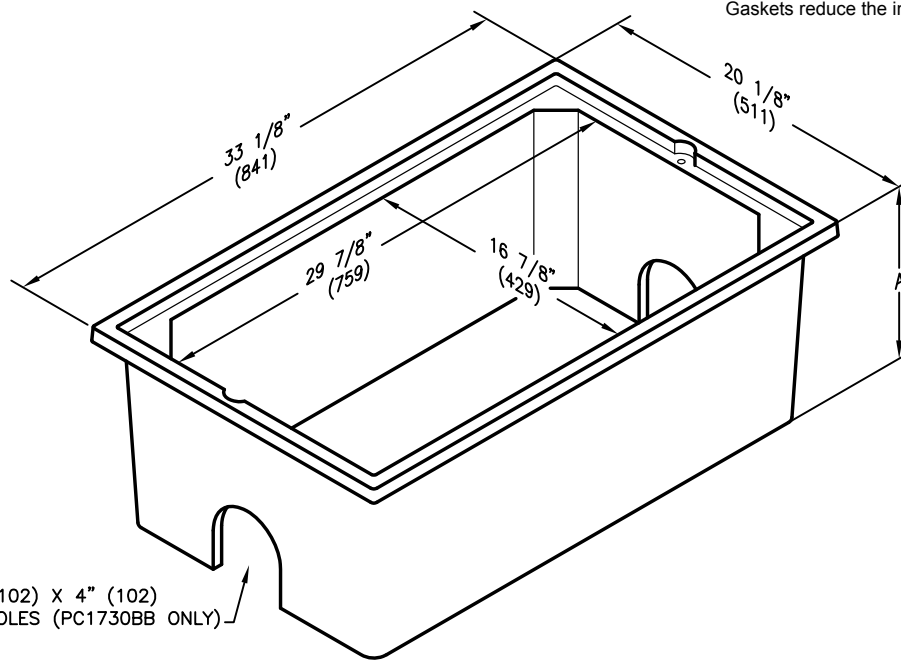

ENCLOSURE DRAWINGS

Boxes (Stackable with self-aligning, replaceable EZ-Nut)

	DESCRIPTION	PART NO.	WEIGHT #	DIMENSION A	DIMENSION B	DESIGN/TEST LOAD #	ANSI TIER*
Ⓛ	Open Bottom	PC1730BA12	58 (26.3 kg)	12" (305 mm)	N/A	5,000 / 7,500	5
Ⓛ	Open Bottom w/Gasket	PC1730BG12	58 (26.3 kg)	12" (305 mm)	N/A	5,000 / 7,500	5
Ⓛ	Open Bottom w/2 Mouseholes	PC1730BB12	58 (26.3 kg)	12" (305 mm)	N/A	5,000 / 7,500	5
Ⓛ	Solid Bottom	PC1730DA12	83 (37.6 kg)	12 1/2" (318 mm)	N/A	5,000 / 7,500	5
Ⓛ	Solid Bottom w/Gasket	PC1730DG12	83 (37.6 kg)	12 1/2" (318 mm)	N/A	5,000 / 7,500	5
Ⓛ	Footed Box	PC1730JA12	67 (30.4 kg)	12 1/2" (318 mm)	2 7/8" (73 mm)	5,000 / 7,500	5

Dimensions & weights in parentheses are metric equivalent.

* Loadings comply with ANSI/SCTE 77 (see page 9).



SPECIFICATIONS/DATA

17" x 30" PG Style (Stackable) Assembly and 17" x 30" PD Style Assembly

ENCLOSURE DRAWINGS

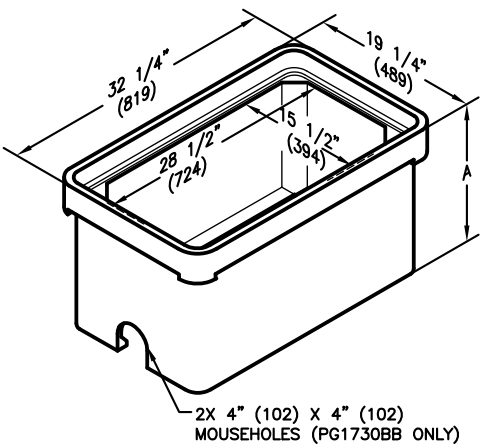
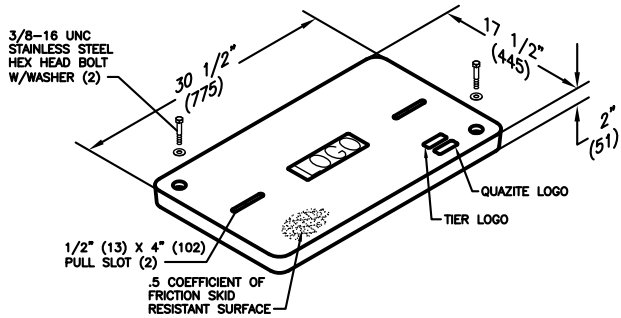

2X 4" (102) X 4" (102) MOUSEHOLES (PG1730BB ONLY)

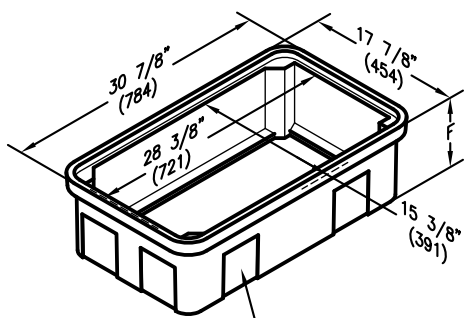
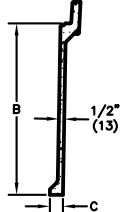

4 3/4" (121) X 4 5/8" (117) KNOCKOUTS (6)

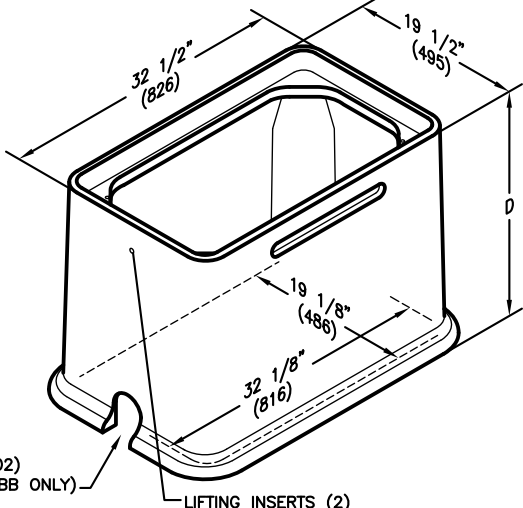
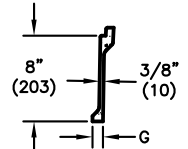

2X 4" (102) X 4" (102) MOUSEHOLES (PD1730BB ONLY)

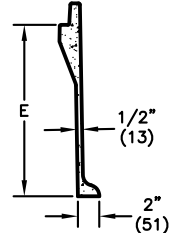

17" x 30" PG Style (Stackable) Assembly and 17" x 30 PD Style Assembly

SPECIFICATIONS/DATA

Covers (Blank unless logo is specified)

	DESCRIPTION	PART NO.	WEIGHT #	DESIGN/TEST LOAD #	ANSI TIER*
Ⓢ	W/2 Bolts	PG1730CA00	52 (23.6 kg)	8,000 / 12,000	8
Ⓢ	Gasketed w/2 Bolts	PG1730CG00	52 (23.6 kg)	8,000 / 12,000	8
Ⓢ	No Bolts	PG1730WA00	52 (23.6 kg)	8,000 / 12,000	8
Ⓢ	Heavy Duty w/2 Bolts	PG1730HA00	83 (37.6 kg)	15,000 / 22,500	15
Ⓢ	Gasketed Heavy Duty w/2 Bolts	PG1730HG00	83 (37.6 kg)	15,000 / 22,500	15
Ⓢ	Extra Heavy Duty w/2 Bolts	PG1730HH00	83 (37.6 kg)	22,500 / 33,750	22

- Covers with meter lids available upon request. See page 12 or page 57 for meter lid cover load rating explanation.
- Gasketed covers and bolt grommets must be used with a gasketed box. Gaskets reduce the inflow of fluids but do not make the enclosure water tight.

PG Boxes (Stackable with self-aligning, replaceable EZ Nut) **22" - 30" Deep boxes must be used as bottom of any stack.)

	DESCRIPTION	PART NO.	WEIGHT #	DIMENSION A	DIMENSION B	DIMENSION C	DESIGN/TEST LOAD #	ANSI TIER*
Ⓢ	Open Bottom	PG1730BA12	67 (30.4 kg)	12" (305 mm)	10" (254 mm)	1 1/4" (32 mm)	22,500 / 33,750	22
		PG1730BA18	94 (42.6 kg)	18" (457 mm)	16" (406 mm)	1 1/4" (32 mm)	22,500 / 33,750	22
		PG1730BA22	106 (48.1 kg)	22" (559 mm)	20" (508 mm)	1 1/4" (32 mm)	22,500 / 33,750	22
		PG1730BA24	122 (55.3 kg)	24" (610 mm)	22" (559 mm)	1 1/4" (32 mm)	22,500 / 33,750	22
		PG1730BA28	126 (57.2 kg)	28" (711 mm)	26" (660 mm)	1/2" (13 mm)	22,500 / 33,750	22
		PG1730BA30	144 (65.3 kg)	30" (762 mm)	28" (711 mm)	1/2" (13 mm)	22,500 / 33,750	22
Ⓢ	Open Bottom w/2 Mouseholes	PG1730BB12	65 (29.5 kg)	12" (305 mm)	10" (254 mm)	1 1/4" (32 mm)	22,500 / 33,750	22
		PG1730BB18	92 (41.7 kg)	18" (457 mm)	16" (406 mm)	1 1/4" (32 mm)	22,500 / 33,750	22
		PG1730BB22	104 (47.2 kg)	22" (559 mm)	20" (508 mm)	1 1/4" (32 mm)	22,500 / 33,750	22
		PG1730BB24	120 (54.4 kg)	24" (610 mm)	22" (559 mm)	1 1/4" (32 mm)	22,500 / 33,750	22
		PG1730BB28	124 (56.2 kg)	28" (711 mm)	26" (660 mm)	1/2" (13 mm)	22,500 / 33,750	22
		PG1730BB30	142 (64.4 kg)	30" (762 mm)	28" (711 mm)	1/2" (13 mm)	22,500 / 33,750	22
Ⓢ	Open Bottom w/Gasket	PG1730BG12	67 (30.4 kg)	12" (305 mm)	10" (254 mm)	1 1/4" (32 mm)	22,500 / 33,750	22
		PG1730BG18	94 (42.6 kg)	18" (457 mm)	16" (406 mm)	1 1/4" (32 mm)	22,500 / 33,750	22
		PG1730BG22	106 (48.1 kg)	22" (559 mm)	20" (508 mm)	1 1/4" (32 mm)	22,500 / 33,750	22
		PG1730BG24	122 (55.3 kg)	24" (610 mm)	22" (559 mm)	1 1/4" (32 mm)	22,500 / 33,750	22
		PG1730BG28	126 (57.2 kg)	28" (711 mm)	26" (660 mm)	1/2" (13 mm)	22,500 / 33,750	22
		PG1730BG30	144 (65.3 kg)	30" (762 mm)	28" (711 mm)	1/2" (13 mm)	22,500 / 33,750	22
Ⓢ	Solid Bottom	PG1730DA12	85 (38.5 kg)	12 1/2" (318 mm)	10" (254 mm)	N/A	22,500 / 33,750	22
		PG1730DA18	112 (50.8 kg)	18 1/2" (470 mm)	16" (406 mm)	N/A	22,500 / 33,750	22
		PG1730DA22	124 (56.2 kg)	22 1/2" (572 mm)	20" (508 mm)	N/A	22,500 / 33,750	22
		PG1730DA24	137 (62.0 kg)	24 1/2" (622 mm)	22" (559 mm)	N/A	22,500 / 33,750	22
		PG1730DA28	143 (64.9 kg)	28 1/2" (724 mm)	26" (660 mm)	N/A	22,500 / 33,750	22
		PG1730DA30	150 (68.0 kg)	30 1/2" (775 mm)	28" (711 mm)	N/A	22,500 / 33,750	22

PD Boxes

	DESCRIPTION	PART NO.	WEIGHT #	DIMENSION D	DIMENSION E	DESIGN/TEST LOAD #	ANSI TIER*
Ⓢ	Open Bottom	PD1730BA18	129 (59 kg)	18" (457 mm)	16" (406 mm)	22,500 / 33,750	22
		PD1730BA26	166 (75 kg)	26" (660 mm)	24" (610 mm)	22,500 / 33,750	22
Ⓢ	Open Bottom w/2 Mouseholes	PD1730BB18	127 (58 kg)	18" (457 mm)	16" (406 mm)	22,500 / 33,750	22
		PD1730BB26	164 (74 kg)	26" (660 mm)	24" (610 mm)	22,500 / 33,750	22
Ⓢ	Open Bottom w/Gasket	PD1730BG18	129 (59 kg)	18" (457 mm)	16" (406 mm)	22,500 / 33,750	22
		PD1730BG26	166 (75 kg)	26" (660 mm)	24" (610 mm)	22,500 / 33,750	22

Extensions (For use under 12" and 18" boxes only, one per box.)

	DESCRIPTION	PART NO.	WEIGHT #	DIMENSION F	DIMENSION G	DESIGN/TEST LOAD #	ANSI TIER*
	Open Bottom	PG1730EA08	36 (16.3 kg)	8 3/4" (222 mm)	1" (25 mm)	22,500 / 33,750	22
	Solid Bottom	PG1730RA08	55 (24.9 kg)	9 1/4" (235 mm)	N/A	22,500 / 33,750	22

Dimensions & weights in parentheses are metric equivalent.

* Loadings comply with ANSI/SCTE 77 (see page 9).



SPECIFICATIONS/DATA

17" x 30" PT Style (Nestable) Assembly

Covers (Blank unless logo is specified)

	DESCRIPTION	PART NO.	WEIGHT #	DESIGN/TEST LOAD #	ANSI TIER*
UL	W/2 Bolts	PT1730CA00	52 (23.6 kg)	8,000 / 12,000	8
UL	Gasketed w/2 Bolts	PT1730CG00	52 (23.6 kg)	8,000 / 12,000	8
UL	No Bolts	PT1730WA00	52 (23.6 kg)	8,000 / 12,000	8
UL	Heavy Duty w/2 Bolts	PT1730HA00	83 (37.6 kg)	15,000 / 22,500	15
UL	Gasketed Heavy Duty w/2 Bolts	PT1730HG00	83 (37.6 kg)	15,000 / 22,500	15

- Covers with meter lids available upon request. See page 12 or page 57 for meter lid cover load rating explanation.
- PT covers are PG covers with shorter bolts
- Gasketed covers and bolt grommets must be used with a gasketed box. Gaskets reduce the inflow of fluids but do not make the enclosure water tight.

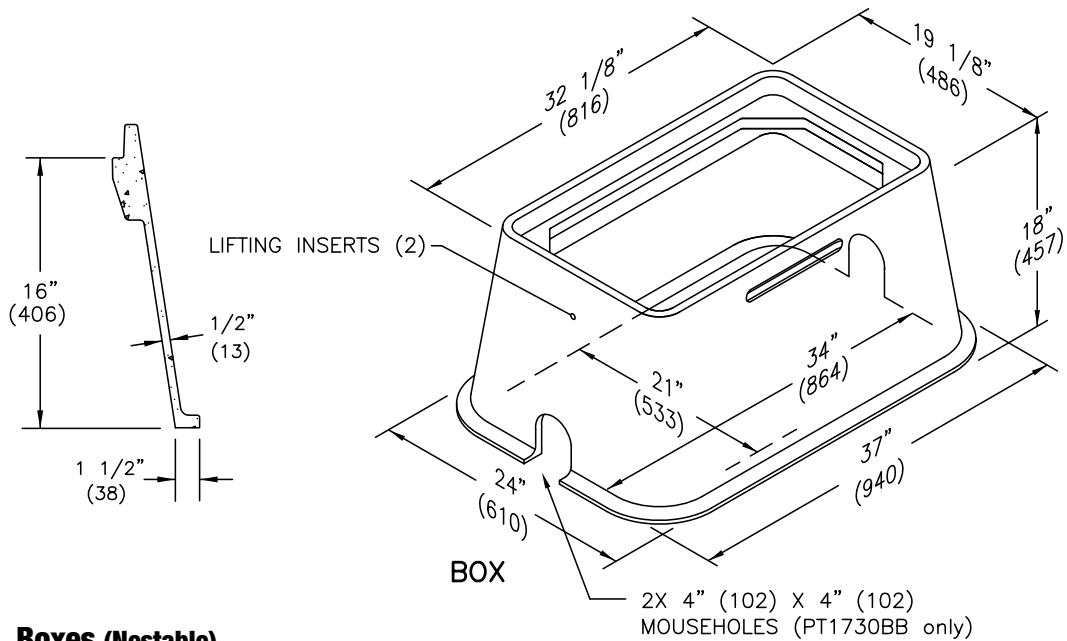
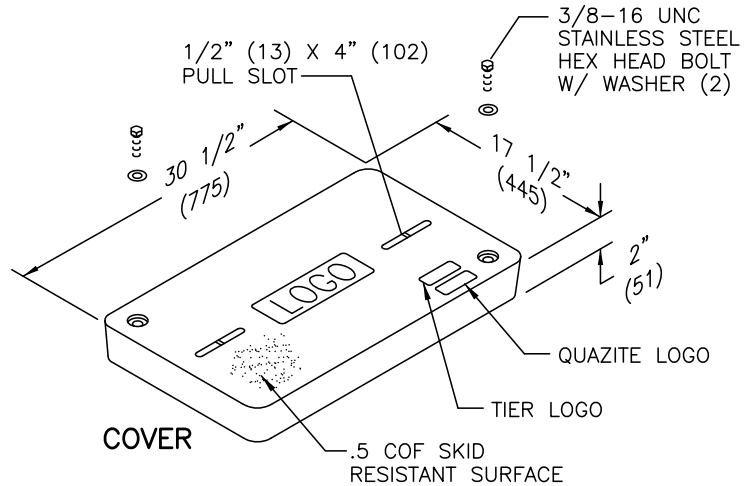

Boxes (Nestable)

	DESCRIPTION	PART NO.	WEIGHT #	DESIGN/TEST LOAD #	ANSI TIER*
UL	Open Bottom	PT1730BA18	126 (57.2 kg)	15,000 / 22,500	15
UL	Open Bottom w/Gasket	PT1730BG18	126 (57.2 kg)	15,000 / 22,500	15
UL	Open Bottom w/2 Mouseholes	PT1730BB18	125 (56.7 kg)	15,000 / 22,500	15

Dimensions & weights in parentheses are metric equivalent.
 * Loadings comply with ANSI/SCTE 77 (see page 9).



SPECIFICATIONS/DATA

24" x 24" PG Style (Stackable) Assembly

Covers (Blank unless logo is specified)

	DESCRIPTION	PART NO.	WEIGHT #	DESIGN/TEST LOAD #	ANSI TIER*
Ⓛ	W/2 Bolts	PG2424CA00	70 (32.0 kg)	8,000 / 12,000	8
Ⓛ	Gasketed w/2 Bolts	PG2424CG00	70 (32.0 kg)	8,000 / 12,000	8
Ⓛ	No Bolts	PG2424WA00	70 (32.0 kg)	8,000 / 12,000	8
Ⓛ	Heavy Duty w/2 Bolts	PG2424HA00	100 (45.4 kg)	15,000 / 22,500	15
Ⓛ	Gasketed Heavy Duty w/2 Bolts	PG2424HG00	100 (45.4 kg)	15,000 / 22,500	15
Ⓛ	Extra Heavy Duty w/2 Bolts	PG2424HH00	100 (45.4 kg)	22,500 / 33,750	22

- Covers with meter lids available upon request. See page 12 or page 57 for meter lid cover load rating explanation.
- Gasketed covers and bolt grommets must be used with a gasketed box. Gaskets reduce the inflow of fluids but do not make the enclosure water tight.

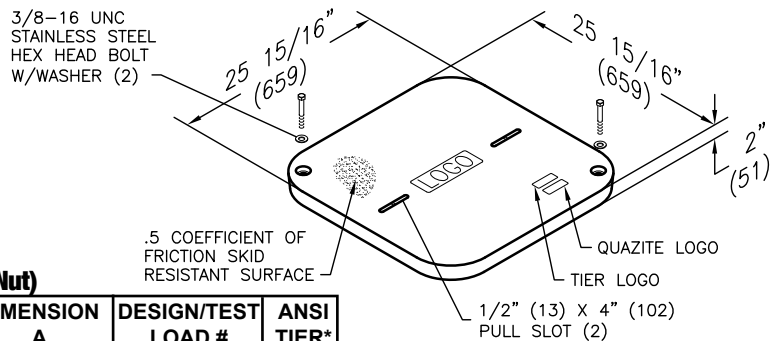

Boxes (Stackable with self-aligning, replaceable EZ Nut)

	DESCRIPTION	PART NO.	WEIGHT #	DIMENSION A	DESIGN/TEST LOAD #	ANSI TIER*
Ⓛ	Open Bottom	PG2424BA24	165 (75.0 kg)	24" (610 kg)	22,500 / 33,750	22
Ⓛ	Open Bottom w/Gasket	PG2424BG24	165 (75.0 kg)	24" (610 kg)	22,500 / 33,750	22
Ⓛ	Open Bottom w/2 Mouseholes	PG2424BB24	165 (75.0 kg)	24" (610 kg)	22,500 / 33,750	22
Ⓛ	Solid Bottom	PG2424DA24	185 (83.0 kg)	24 1/2" (622 kg)	22,500 / 33,750	22
Ⓛ	Solid Bottom w/Gasket	PG2424DG24	185 (83.0 kg)	24 1/2" (622 kg)	22,500 / 33,750	22

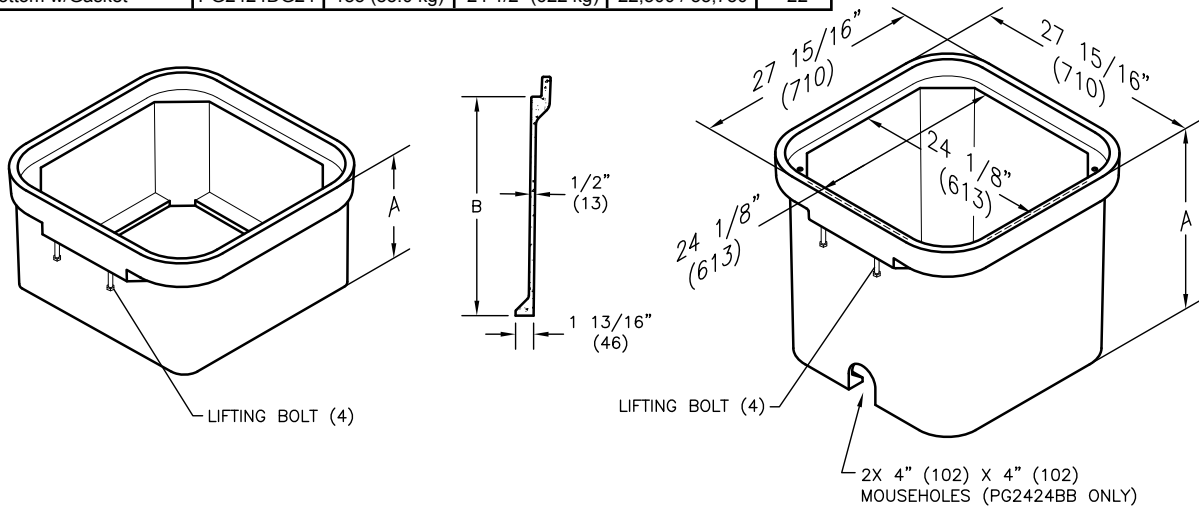

Extensions (Stackable - can be used as a top or bottom extension)

	DESCRIPTION	PART NO.	WEIGHT #	DIMENSION A	DESIGN/TEST LOAD #	ANSI TIER*
	Open Bottom	PG2424EA06	71 (32.0 kg)	8" (203 mm)	15,000 / 22,500	15
		PG2424EA12	112 (51.0 kg)	14" (356 mm)	15,000 / 22,500	15
	Solid Bottom	PG2424RA06	96 (44.0 kg)	8 1/2" (216 mm)	15,000 / 22,500	15
		PG2424RA12	130 (59.0 kg)	14 1/2" (368 mm)	15,000 / 22,500	15



Dimensions & weights in parentheses are metric equivalent.
* Loadings comply with ANSI/SCTE 77 (see page 9).

SPECIFICATIONS/DATA

24" x 36" PG Style (Stackable) Assembly and 24" x 36" PD Style Assembly

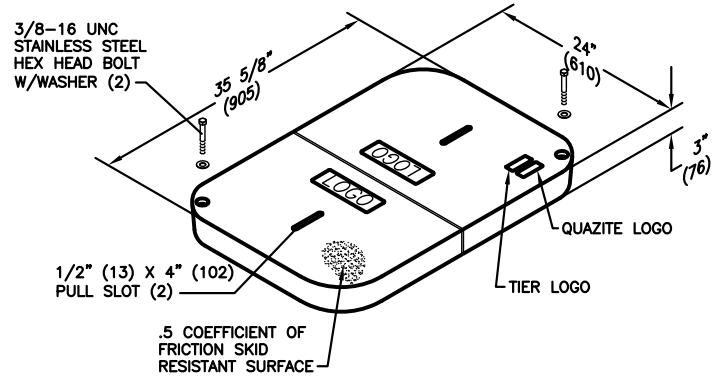
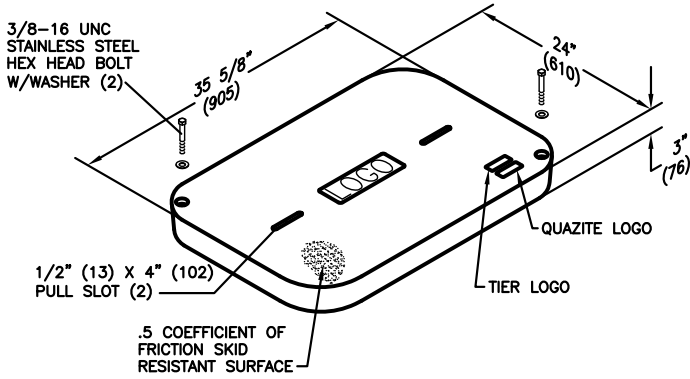

ENCLOSURE DRAWINGS

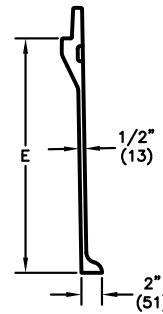
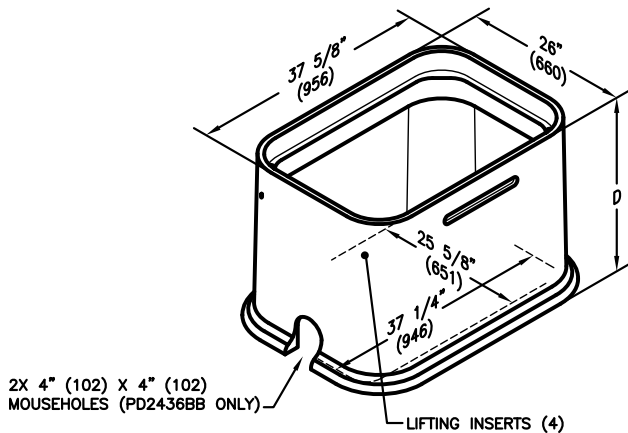
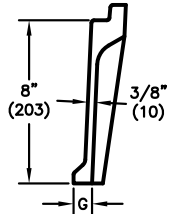
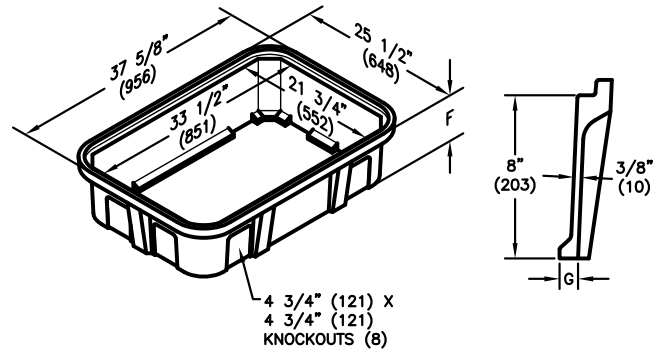
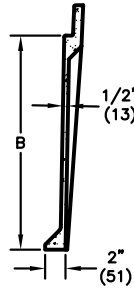
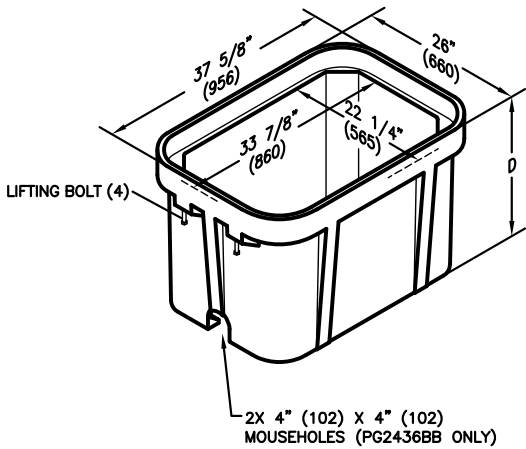

24" x 36" PG Style (Stackable) Assembly and 24" x 36" PD Style Assembly

SPECIFICATIONS/DATA

Covers (Blank unless logo is specified)

	DESCRIPTION	PART NO.	WEIGHT #	DESIGN/TEST LOAD #	ANSI TIER*
Ⓛ	W/2 Bolts	PG2436CA00	100 (45 kg)	8,000 / 12,000	8
Ⓛ	Gasketed w/2 Bolts	PG2436CG00	100 (45 kg)	8,000 / 12,000	8
	2-Piece w/2 Bolts	PG2436CS00	122 (55 kg)	8,000 / 12,000	8
Ⓛ	No Bolts	PG2436WA00	100 (45 kg)	8,000 / 12,000	8
Ⓛ	Heavy Duty w/2 Bolts	PG2436HA00	115 (52 kg)	15,000 / 22,500	15
Ⓛ	Gasketed Heavy Duty w/2 Bolts	PG2436HG00	115 (52 kg)	15,000 / 22,500	15
Ⓛ	Heavy Duty 2-Piece w/2 Bolts	PG2436HS00	122 (55 kg)	15,000 / 22,500	15
Ⓛ	Heavy Duty w/2 Bolts	PG2436HH00	122 (55 kg)	22,500 / 33,750	22

- Covers with meter lids available upon request. See page 12 or page 57 for meter lid cover load rating explanation.
- Gasketed covers and bolt grommets must be used with a gasketed box. Gaskets reduce the inflow of fluids but do not make the enclosure water tight.

PG Boxes (Stackable with self-aligning, replaceable EZ Nut) **24" - 42" Deep boxes must be used as bottom of any stack.)

	DESCRIPTION	PART NO.	WEIGHT #	DIMENSION A	DIMENSION B	DESIGN/TEST LOAD #	ANSI TIER*
Ⓛ	Open Bottom	PG2436BA18	141 (64 kg)	18" (457 mm)	15" (381 mm)	22,500 / 33,750	22
		PG2436BA24	180 (81.6 kg)	24" (610 mm)	21" (533 mm)	22,500 / 33,750	22
		PG2436BA30	196 (88.9 kg)	30" (762 mm)	27" (686 mm)	22,500 / 33,750	22
		PG2436BA36	254 (115 kg)	36" (914 mm)	33" (838 mm)	22,500 / 33,750	22
		PG2436BA42	293 (133 kg)	42" (1067 mm)	39" (991 mm)	22,500 / 33,750	22
Ⓛ	Open Bottom w/2 Mouseholes	PG2436BB18	139 (63.1 kg)	18" (457 mm)	15" (381 mm)	22,500 / 33,750	22
		PG2436BB24	178 (80.7 kg)	24" (610 mm)	21" (533 mm)	22,500 / 33,750	22
		PG2436BB30	194 (88.0 kg)	30" (762 mm)	27" (686 mm)	22,500 / 33,750	22
		PG2436BB36	252 (114 kg)	36" (914 mm)	33" (838 mm)	22,500 / 33,750	22
		PG2436BB42	293 (133 kg)	42" (1067 mm)	39" (991 mm)	22,500 / 33,750	22
Ⓛ	Open Bottom w/Gasket	PG2436BG18	141 (64 kg)	18" (457 mm)	15" (381 mm)	22,500 / 33,750	22
		PG2436BG24	180 (81.6 kg)	24" (610 mm)	21" (533 mm)	22,500 / 33,750	22
		PG2436BG30	196 (88.9 kg)	30" (762 mm)	27" (686 mm)	22,500 / 33,750	22
		PG2436BG36	254 (115 kg)	36" (914 mm)	33" (838 mm)	22,500 / 33,750	22
		PG2436BG42	293 (133 kg)	42" (1067 mm)	39" (991 mm)	22,500 / 33,750	22
Ⓛ	Solid Bottom	PG2436DA18	171 (78 kg)	18 1/2" (470 mm)	15" (381 mm)	22,500 / 33,750	22
		PG2436DA24	228 (103.4 kg)	24 1/2" (622 mm)	21" (533 mm)	22,500 / 33,750	22
		PG2436DA30	238 (107.0 kg)	30 1/2" (775 mm)	27" (686 mm)	22,500 / 33,750	22
		PG2436DA36	282 (128 kg)	36 1/2" (927 mm)	33" (838 mm)	22,500 / 33,750	22
		PG2436DA42	321 (146 kg)	42 1/2" (1080 mm)	39" (991 mm)	22,500 / 33,750	22

PD Boxes

	DESCRIPTION	PART NO.	WEIGHT #	DIMENSION D	DIMENSION E	DESIGN/TEST LOAD #	ANSI TIER*
Ⓛ	Open Bottom	PD2436BA18	159 (72 kg)	18" (457 mm)	15" (381 mm)	22,500 / 33,750	22
Ⓛ		PD2436BA26	199 (90 kg)	26" (660 mm)	23" (584 mm)	22,500 / 33,750	22
		PD2436BA48	313 (142 kg)	48" (1219 mm)	45" (1143 mm)	22,500 / 33,750	22
Ⓛ	Open Bottom w/2 Mouseholes	PD2436BB18	157 (71 kg)	18" (457 mm)	15" (381 mm)	22,500 / 33,750	22
Ⓛ		PD2436BB26	197 (89 kg)	26" (660 mm)	23" (584 mm)	22,500 / 33,750	22
		PD2436BB48	311 (141 kg)	48" (1219 mm)	45" (1143 mm)	22,500 / 33,750	22
Ⓛ	Open Bottom w/Gasket	PD2436BG18	159 (72 kg)	18" (457 mm)	15" (381 mm)	22,500 / 33,750	22
Ⓛ		PD2436BG26	199 (90 kg)	26" (660 mm)	23" (584 mm)	22,500 / 33,750	22
		PD2436BG48	313 (142 kg)	48" (1219 mm)	45" (1143 mm)	22,500 / 33,750	22

Extensions (For use under 18" deep box only, one per box.)

	DESCRIPTION	PART NO.	WEIGHT #	DIMENSION F	DIMENSION G	DESIGN/TEST LOAD #	ANSI TIER*
	Open Bottom	PG2436EA08	81 (37 kg)	8 3/4" (222 mm)	1" (25 mm)	22,500 / 33,750	22
	Solid Bottom	PG2436RA08	95 (43.1 kg)	9 1/4" (235 mm)	N/A	22,500 / 33,750	22

Dimensions & weights in parentheses are metric equivalent.

* Loadings comply with ANSI/SCTE 77 (see page 9).



SPECIFICATIONS/DATA

30" x 48" PG Style (Stackable) Assembly 30" x 48" PD Style (Nestable) Assembly

ENCLOSURE DRAWINGS

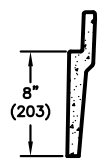
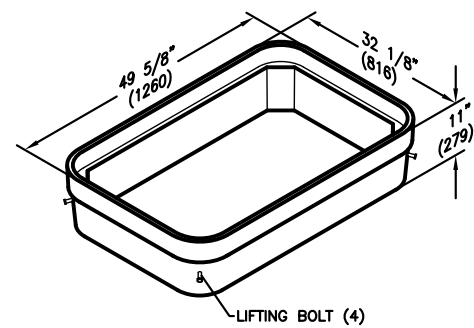
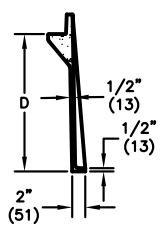
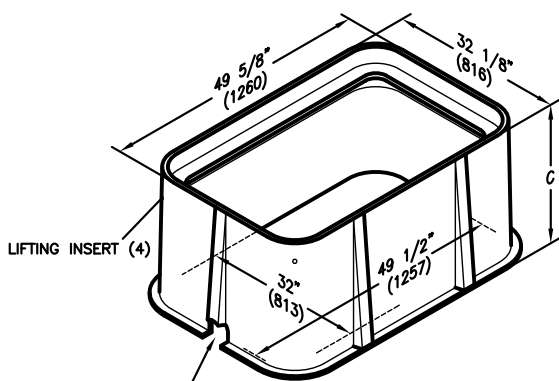
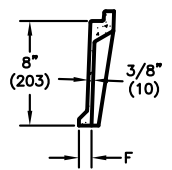
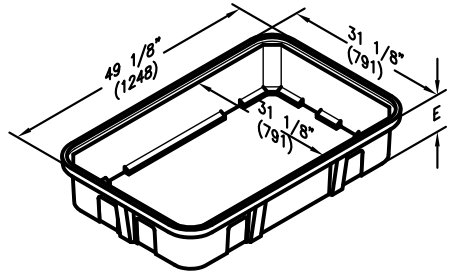
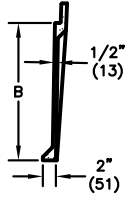
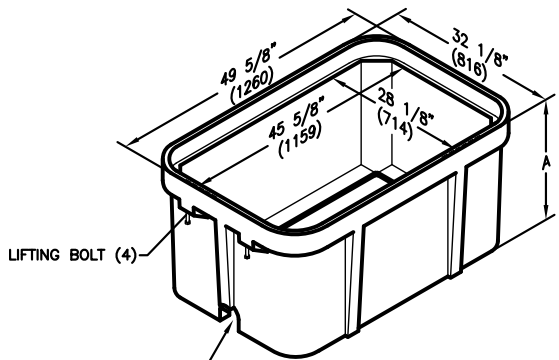
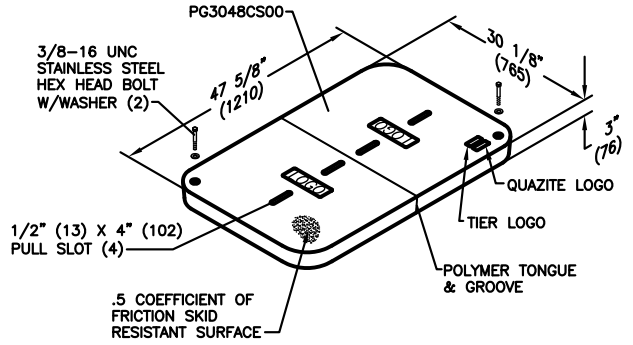
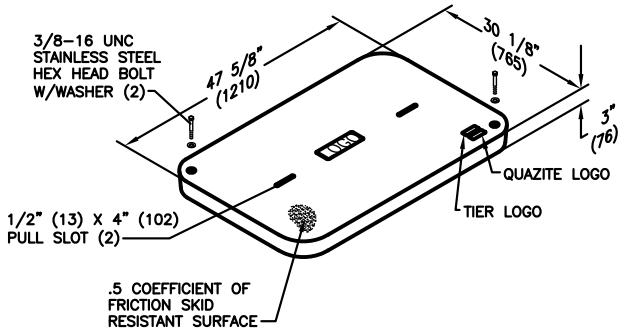
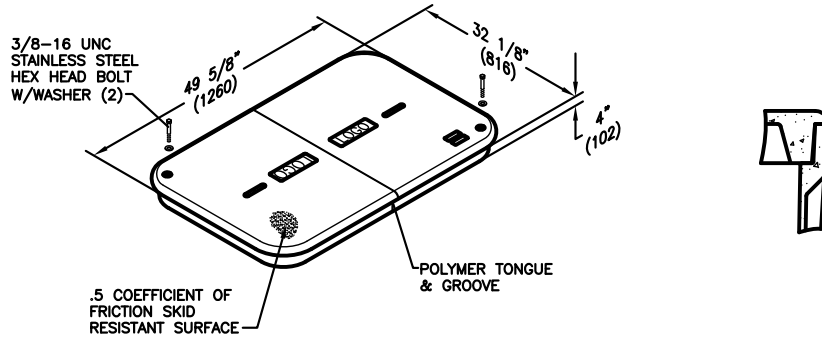

SPECIFICATIONS/DATA

30" x 48" PG Style (Stackable) Assembly 30" x 48" PD Style (Nestable) Assembly

Covers (Blank unless logo is specified)

DESCRIPTION	PART NO.	WEIGHT #	DESIGN/TEST LOAD	ANSI TIER*
W/2 Bolts	PG3048CA00	159 (72.1 kg)	8,000 / 12,000	8
Gasketed w/2 Bolts	PG3048CG00	159 (72.1 kg)	8,000 / 12,000	8
No Bolts	PG3048WA00	159 (72.1 kg)	8,000 / 12,000	8
Heavy Duty w/2 Bolts	PG3048HA00	206 (93.4 kg)	15,000 / 22,500	15
Gasketed Heavy Duty w/2 Bolts	PG3048HG00	206 (93.4 kg)	15,000 / 22,500	15
Extra Heavy Duty w/2 Bolts	PG3048HH00	220 (99.7 kg)	22,500 / 33,750	22
2-piece w/2 Bolts	PG3048CS00	181 (82.1 kg)	8,000 / 12,000	8
Heavy Duty 2-piece w/2 Bolts	PG3048HS00	206 (93.4 kg)	15,000 / 22,500	15
2-piece Overlapping	PG3048CC00	248 (112.0 kg)	8,000 / 12,000	8
Heavy Duty 2-piece Overlapping	PG3048HC00	248 (112.0 kg)	15,000 / 22,500	15

- Covers with meter lids available upon request. See page 12 or page 57 for meter lid cover load rating explanation.
- Gasketed covers and bolt grommets must be used with a gasketed box. Gaskets reduce the inflow of fluids but do not make the enclosure water tight.

PG Boxes (Stackable with self-aligning, replaceable EZ-Nut) *24" & 36" deep boxes must be used as bottom of any stack

DESCRIPTION	PART NO.	WEIGHT #	DIMENSION A	DIMENSION B	DESIGN/TEST LOAD #	ANSI TIER*
Open Bottom	PG3048BA18	185 (83.9 kg)	18" (457 mm)	15" (381 mm)	22,500 / 33,750	22
	PG3048BA24	236 (107.0 kg)	24" (609 mm)	21" (533 mm)	22,500 / 33,750	22
	PG3048BA36	343 (155.6 kg)	36" (914 mm)	33" (838 mm)	22,500 / 33,750	22
Open Bottom w/ Gasket	PG3048BG18	185 (83.9 kg)	18" (457 mm)	15" (381 mm)	22,500 / 33,750	22
	PG3048BG24	236 (107.0 kg)	24" (609 mm)	21" (533 mm)	22,500 / 33,750	22
	PG3048BG36	343 (155.6 kg)	36" (914 mm)	33" (838 mm)	22,500 / 33,750	22
Open Bottom w/ 2 Mouseholes	PG3048BB18	185 (83.9 kg)	18" (457 mm)	15" (381 mm)	22,500 / 33,750	22
	PG3048BB24	236 (107.0 kg)	24" (610 mm)	21" (533 mm)	22,500 / 33,750	22
	PG3048BB36	343 (155.6 kg)	36" (914 mm)	33" (838 mm)	22,500 / 33,750	22
Solid Bottom	PG3048DA18	220 (99.8 kg)	18 1/2" (470 mm)	15" (381 mm)	22,500 / 33,750	22
	PG3048DA24	287 (130.2 kg)	24 1/2" (622 mm)	21" (533 mm)	22,500 / 33,750	22
	PG3048DA36	394 (178.7 kg)	36 1/2" (927 mm)	33" (838 mm)	22,500 / 33,750	22
Solid Bottom w/ Gasket	PG3048DG18	220 (99.8 kg)	18 1/2" (470 mm)	15" (381 mm)	22,500 / 33,750	22
	PG3048DG24	287 (130.2 kg)	24 1/2" (622 mm)	21" (533 mm)	22,500 / 33,750	22
	PG3048DG36	394 (178.7 kg)	36 1/2" (927 mm)	33" (838 mm)	22,500 / 33,750	22

PD Boxes (Nestable)

DESCRIPTION	PART NO.	WEIGHT #	DIMENSION C	DIMENSION D	DESIGN/TEST LOAD #	ANSI TIER*
Open Bottom	PD3048BA24	286 (130 kg)	24" (610 mm)	21" (533 mm)	22,500 / 33,750	22
	PD3048BA48	614 (278.5 kg)	48" (1219 mm)	45" (1143 mm)	22,500 / 33,750	22
Open Bottom w/ Gasket	PD3048BG24	286 (130 kg)	24" (610 mm)	21" (533 mm)	22,500 / 33,750	22
	PD3048BG48	614 (278.5 kg)	48" (1219 mm)	45" (1143 mm)	22,500 / 33,750	22
Open Bottom w/ 2 Mouseholes	PD3048BB24	286 (130 kg)	24" (610 mm)	21" (533 mm)	22,500 / 33,750	22
	PD3048BB48	614 (278.5 kg)	48" (1219 mm)	45" (1143 mm)	22,500 / 33,750	22

Top Extension (For use on top of PG and PD boxes of any depth)

DESCRIPTION	PART NO.	WEIGHT #	DESIGN/TEST LOAD #	ANSI TIER*
Open Bottom*	PG3048EA11	100 (45.4 kg)	22,500 / 33,750	22

* In addition, this extension can be used as a bottom extension for 18" deep PG boxes.

Bottom Extensions (For use under 18" deep PG style box only, one per box)

DESCRIPTION	PART NO.	WEIGHT #	DIMENSION E	DIMENSION F	DESIGN/TEST LOAD #	ANSI TIER*
Open Bottom	PG3048EA08	102 (46.3 kg)	8 3/4" (222 mm)	1" (25 mm)	22,500 / 33,750	22
Solid Bottom	PG3048RA08	151 (58.0 kg)	9 1/4" (235 mm)	N/A	22,500 / 33,750	22

Dimensions & weights in parentheses are metric equivalent.

* Loadings comply with ANSI/SCTE 77 (see page 9).



SPECIFICATIONS/DATA

30" x 60" PG Style (Stackable) Assembly

2-Piece Covers (Blank unless logo is specified)

DESCRIPTION	PART NO.	WEIGHT #	DESIGN/TEST LOAD	ANSI TIER*
Lightweight w/2 Bolts	LG3060CA00	228 (103.4 kg)	5,000 / 7,500	5
Lightweight w/No Bolts	LG3060WA00	228 (103.4 kg)	5,000 / 7,500	5
Heavy Duty w/2 Bolts	PG3060HA00	346 (156.9 kg)	15,000 / 22,500	15
Extra Heavy Duty w/2 Bolts	PG3060HH00	368 (166.9 kg)	22,500 / 33,750	22
Lightweight Overlapping	LG3060CC00	308 (139.7 kg)	5,000 / 7,500	5
Heavy Duty Overlapping	PG3060HC00	404 (183.3 kg)	15,000 / 22,500	15

- Covers with meter lids available upon request. See page 12 or page 57 for meter lid cover load rating explanation.
- Gasketed covers and bolt grommets must be used with a gasketed box. Gaskets reduce the inflow of fluids but do not make the enclosure water tight.

ENCLOSURE DRAWINGS

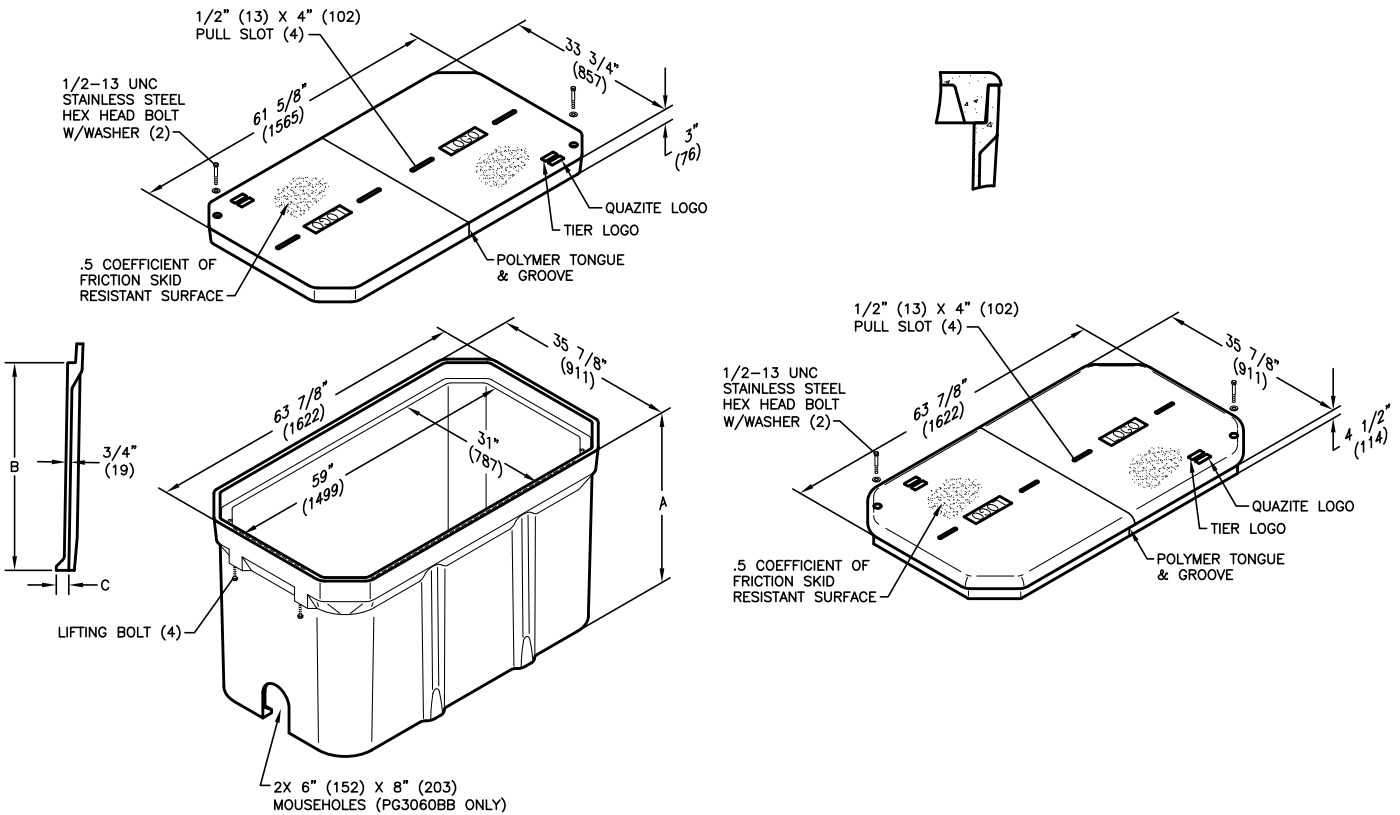

Boxes (Stackable with self-aligning, replaceable EZ-Nut) *30" & 36" deep boxes must be used as bottom of any stack

DESCRIPTION	PART NO.	WEIGHT #	DIMENSION A	DIMENSION B	DIMENSION C	DESIGN/TEST LOAD #	ANSI TIER*
Open Bottom	PG3060BA21	350 (159.0 kg)	21" (533 mm)	18" (457 mm)	2" (51 mm)	22,500 / 33,750	22
	PG3060BA30	492 (223.2 kg)	30" (762 mm)	27" (686 mm)	2 1/8" (54 mm)	22,500 / 33,750	22
	PG3060BA36	565 (256.3 kg)	36" (914 mm)	33" (838 mm)	2 1/8" (54 mm)	22,500 / 33,750	22
Open Bottom w/ 2 Mouseholes	PG3060BB21	350 (159.0 kg)	21" (533 mm)	18" (457 mm)	2" (51 mm)	22,500 / 33,750	22
	PG3060BB30	490 (222.3 kg)	30" (762 mm)	27" (686 mm)	2 1/8" (54 mm)	22,500 / 33,750	22
	PG3060BB36	563 (255.4 kg)	36" (914 mm)	33" (838 mm)	2 1/8" (54 mm)	22,500 / 33,750	22
Solid Bottom	PG3060DA21	420 (190.5 kg)	21 1/2" (546 mm)	18" (457 mm)	N/A	22,500 / 33,750	22
	PG3060DA30	532 (241.3 kg)	30 1/2" (775 mm)	27" (686 mm)	N/A	22,500 / 33,750	22
	PG3060DA36	601 (272.6 kg)	36 1/2" (927 mm)	33" (838 mm)	N/A	22,500 / 33,750	22

Dimensions & weights in parentheses are metric equivalent.
 * Loadings comply with ANSI/SCTE 77 (see page 9).

SPECIFICATIONS/DATA

36" x 36" PG Style (Stackable) Assembly

Covers (Blank unless logo is specified)

	DESCRIPTION	PART NO.	WEIGHT #	DESIGN/TEST LOAD #	ANSI TIER*
Ⓛ	W/2 Bolts	PG3636CA00	174 (79 kg)	8,000 / 12,000	8
Ⓛ	No Bolts	PG3636WA00	174 (79 kg)	8,000 / 12,000	8
Ⓛ	Heavy Duty w/2 Bolts	PG3636HA00	220 (100 kg)	15,000 / 22,500	15
Ⓛ	2-piece w/2 Bolts	PG3636CS00	220 (100 kg)	8,000 / 12,000	8
Ⓛ	Heavy Duty 2-piece w/2 Bolts	PG3636HS00	220 (100 kg)	15,000 / 22,500	15
Ⓛ	Extra Heavy Duty w/2 Bolts	PG3636HH00	330 (150 kg)	22,500 / 33,750	22

* Covers with meter lids available upon request. See page 12 or page 57 for meter lid cover load rating explanation.

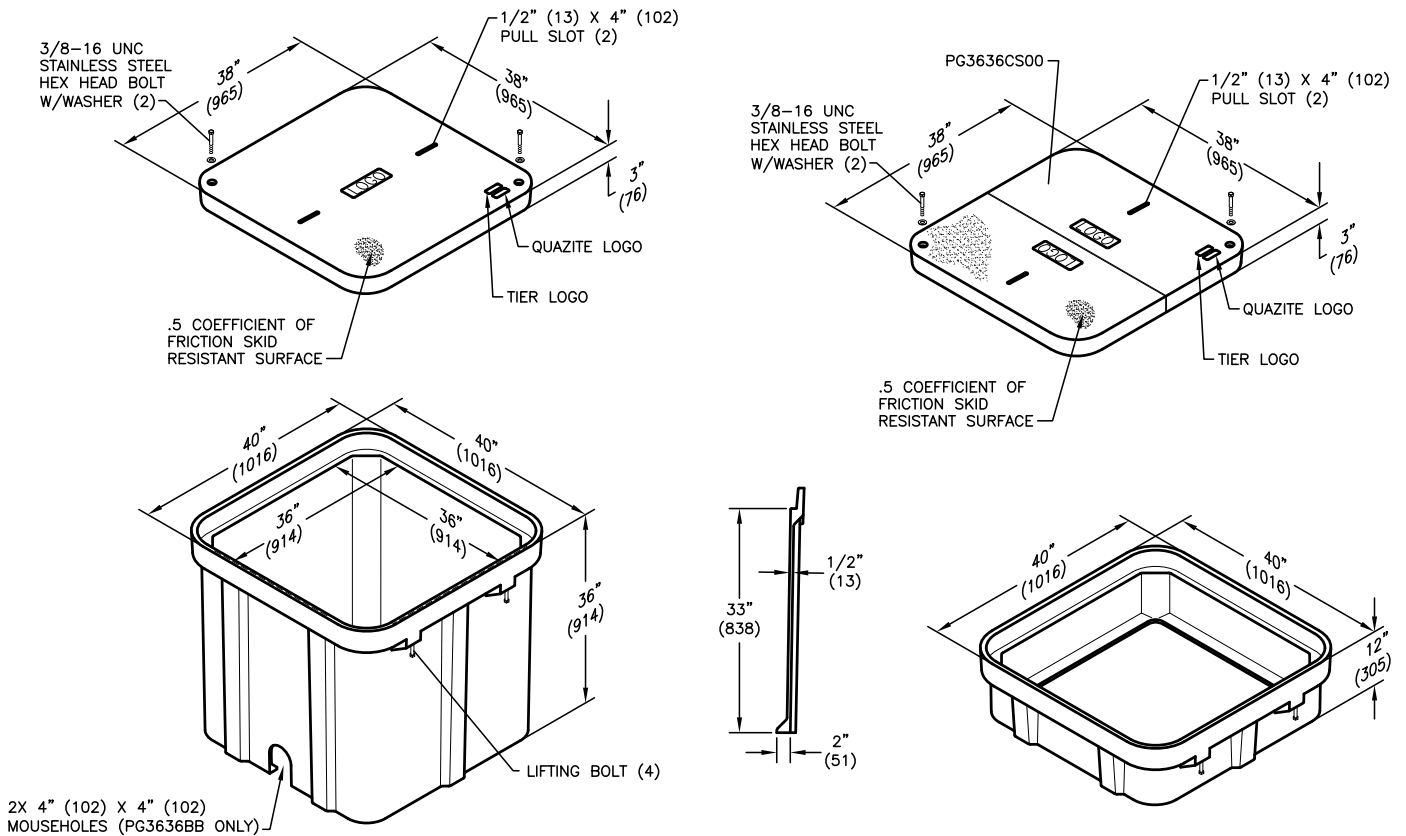

ENCLOSURE DRAWINGS

Boxes (Stackable with self-aligning, replaceable EZ-Nut)

	DESCRIPTION	PART NO.	WEIGHT #	DESIGN/TEST LOAD #	ANSI TIER*
Ⓛ	Open Bottom	PG3636BA36	367 (166 kg)	22,500 / 33,750	22
Ⓛ	Open Bottom w/2 Mouseholes	PG3636BB36	367 (166 kg)	22,500 / 33,750	22
Ⓛ	Solid Bottom	PG3636DA36	407 (185 kg)	22,500 / 33,750	22

Extensions (For use on top of box only)

	DESCRIPTION	PART NO.	WEIGHT #	DESIGN/TEST LOAD #	ANSI TIER*
	Open Bottom	PG3636EA12	129 (59 kg)	22,500 / 33,750	22

Dimensions & weights in parentheses are metric equivalent.

* Loadings comply with ANSI/SCTE 77 (see page 9).



SPECIFICATIONS/DATA

36" x 60" PG Style (Stackable) Assembly

Covers (Blank unless logo is specified)

DESCRIPTION	PART NO.	WEIGHT #	DESIGN/TEST LOAD #	ANSI TIER*
Lightweight w/2 Bolts	LG3660CA00	222 (100.7 kg)	5,000 / 7,500	5
Lightweight w/No Bolts	LG3660WA00	222 (100.7 kg)	5,000 / 7,500	5
Heavy Duty w/2 Bolts	PG3660HA00	384 (174.0 kg)	15,000 / 22,500	15
Extra Heavy Duty w/2 Bolts	PG3660HH00	470 (213.2 kg)	22,500 / 33,750	22
Lightweight Overlapping	LG3660CC00	307 (139.3 kg)	5,000 / 7,500	5
Heavy Duty 2 pc. Overlapping	PG3660HC00	436 (197.8 kg)	15,000 / 22,500	15

• Covers with meter lids available upon request. See page 12 or page 57 for meter lid cover load rating explanation.

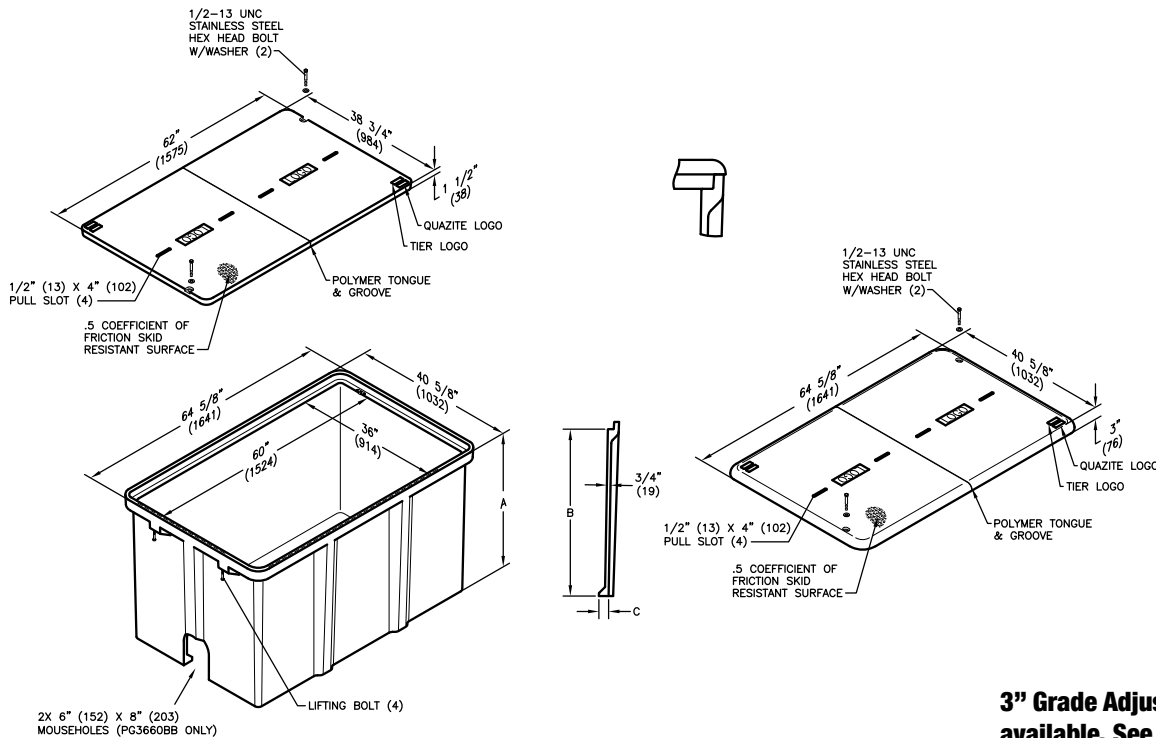

3" Grade Adjustable extension available. See page 45.

Boxes (Stackable with self-aligning, replaceable nut) *31" & 36" deep boxes must be used as bottom of any stack

DESCRIPTION	PART NO.	WEIGHT #	DIMENSION A	DIMENSION B	DIMENSION C	DESIGN/TEST LOAD #	ANSI TIER*
Open Bottom	PG3660BA19	381 (172.8 kg)	19 1/2" (495 mm)	18" (457 mm)	2" (51 mm)	22,500 / 33,750	22
	PG3660BA24	397 (180.0 kg)	24" (610 mm)	22 1/2" (572 mm)	2" (51 mm)	22,500 / 33,750	22
	* PG3660BA31	481 (218.2 kg)	31" (787 mm)	29 1/2" (749 mm)	2" (51 mm)	22,500 / 33,750	22
	* PG3660BA36	647 (293.0 kg)	36" (914 mm)	34 1/2" (876 mm)	2" (51 mm)	22,500 / 33,750	22
Open Bottom w/ 2 Mouseholes	PG3660BB19	379 (171.9 kg)	19 1/2" (495.0 mm)	18" (457 mm)	2" (51 mm)	22,500 / 33,750	22
	PG3660BB24	397 (180.0 kg)	24" (610 mm)	22 1/2" (572 mm)	2" (51 mm)	22,500 / 33,750	22
	* PG3660BB31	479 (217.3 kg)	31" (787 mm)	29 1/2" (749 mm)	2" (51 mm)	22,500 / 33,750	22
	* PG3660BB36	647 (293.0 kg)	36" (914 mm)	34 1/2" (876 mm)	2" (51 mm)	22,500 / 33,750	22
Solid Bottom	PG3660DA19	479 (217.0 kg)	20" (508 mm)	18 1/2" (470 mm)	N/A	22,500 / 33,750	22
	PG3660DA24	495 (224.5 kg)	24 1/2" (622 mm)	23" (584 mm)	N/A	22,500 / 33,750	22
	* PG3660DA31	590 (268.0 kg)	31 1/2" (800.1 mm)	30" (762 mm)	N/A	22,500 / 33,750	22
	* PG3660DA36	738 (334.8 kg)	36 1/2" (927 mm)	35" (889 mm)	N/A	22,500 / 33,750	22

Extensions (For use on top of box only)

DESCRIPTION	PART NO.	WEIGHT #	DIMENSION A	DIMENSION B	DIMENSION C	DESIGN/TEST LOAD #	ANSI TIER*
Open Bottom	PG3660EA12	200 (90.7 kg)	11 1/2"	10"	2"	22,500 / 33,750	22

Dimensions & weights in parentheses are metric equivalent.

* Loadings comply with ANSI/SCTE 77 (see page 9).

JANUARY 2011



SPECIFICATIONS/DATA

36" x 72" PG Style (Stackable) Assembly

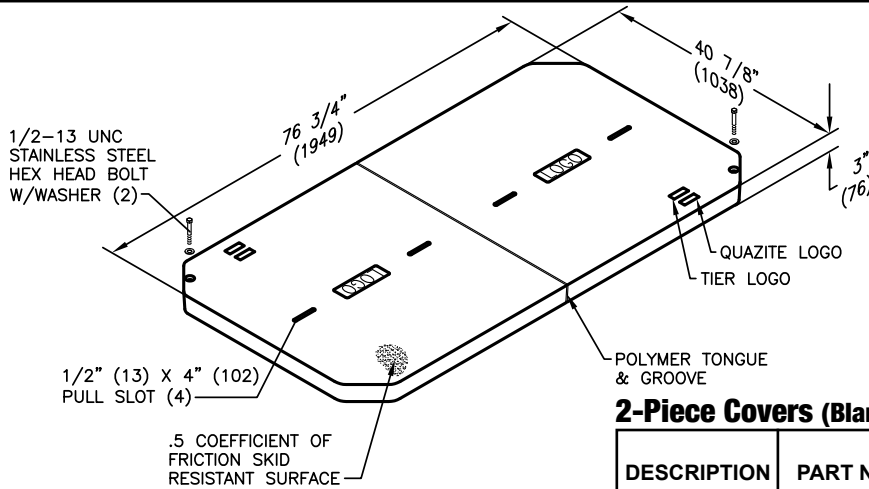

2-Piece Covers (Blank unless logo is specified)

DESCRIPTION	PART NO.	WEIGHT #	DESIGN/TEST LOAD #	ANSI TIER*
Lightweight w/ 2 Bolts	LG3672CA00	310 (140.6 kg)	5,000 / 7,500	5
Lightweight w/ No Bolts	LG3672WA00	310 (140.6 kg)	5,000 / 7,500	5
Heavy Duty w/ 2 Bolts	PG3672HA00	488 (221.0 kg)	15,000 / 22,500	15
Extra Heavy Duty w/2 Bolts	PG3672HH00	544 (246.8 kg)	22,500 / 33,750	22

* Covers with meter lids available upon request. See page 12 or page 57 for meter lid cover load rating explanation.

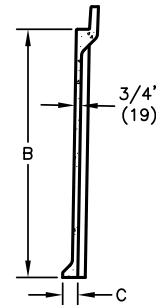
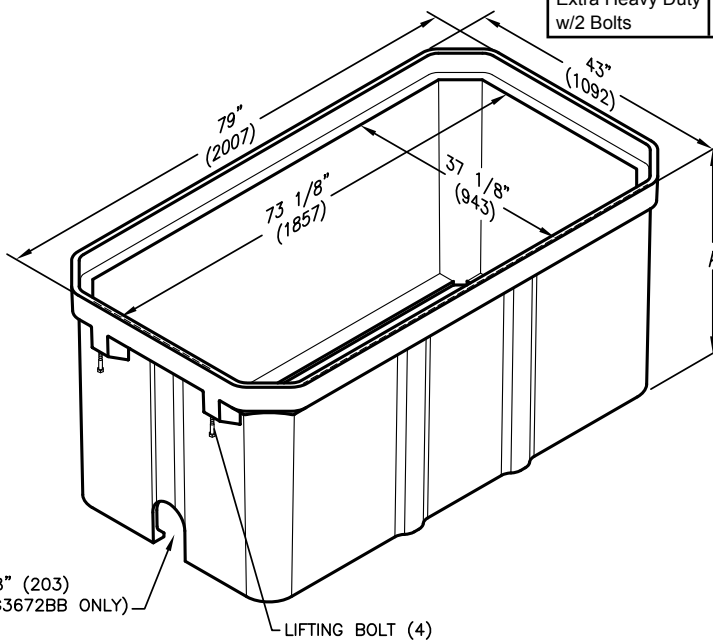

ENCLOSURE DRAWINGS

Boxes (Stackable with self-aligning, replaceable EZ-Nut) *36" deep box must be used as bottom of any stack

DESCRIPTION	PART NO.	WEIGHT #	DIMENSION A	DIMENSION B	DIMENSION C	DESIGN/TEST LOAD #	ANSI TIER*
Open Bottom	PG3672BA21	448 (203.2 kg)	21" (533 mm)	18" (457 mm)	2" (51 mm)	22,500 / 33,750	22
	* PG3672BA36	768 (348.0 kg)	36" (914 mm)	33" (838 mm)	2" (51 mm)	22,500 / 33,750	22
Open Bottom w/ 2 Mouseholes	PG3672BB21	445 (201.9 kg)	21" (533 mm)	18" (457 mm)	2" (51 mm)	22,500 / 33,750	22
	* PG3672BB36	768 (348.0 kg)	36" (914 mm)	33" (838 mm)	2" (51 mm)	22,500 / 33,750	22
Solid Bottom	PG3672DA21	569 (258.1 kg)	21 1/2" (546 mm)	18" (457 mm)	N/A	22,500 / 33,750	22
	* PG3672DA36	822 (373.0 kg)	36 1/2" (927 mm)	33" (838 mm)	N/A	22,500 / 33,750	22

Dimensions & weights in parentheses are metric equivalent.

* Loadings comply with ANSI/SCTE 77 (see page 9).



SPECIFICATIONS/DATA

48" x 48" PG Style (Stackable) Assembly

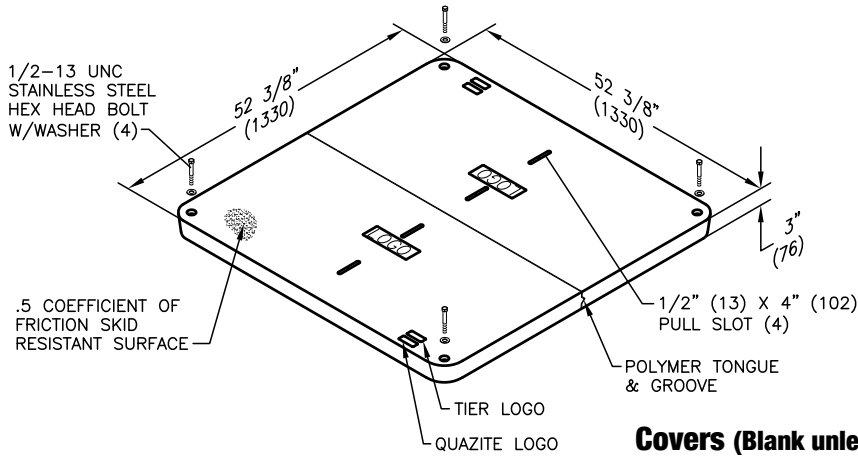

Covers (Blank unless logo is specified)

DESCRIPTION	PART NO.	WEIGHT #	DESIGN/TEST LOAD #	ANSI TIER*
Lightweight w/ 4 Bolts	LG4848CA00	286 (130.0 kg)	5,000 / 7,500	5
Lightweight w/ No Bolts	LG4848WA00	286 (130.0 kg)	5,000 / 7,500	5
Heavy Duty w/W6 x 12 Wide Flange Beam w/4 Bolts*	PG4848HA00	364 (165.1 kg)	15,000 / 22,500	15
Extra Heavy Duty w/ 6 x 4 Tubing w/ 4 Bolts*	PG4848HH00	596 (270.0 kg)	22,500 / 33,750	22
Round 39" Opening	PG4848C500	377 (171 kg)	5,000 / 7,500	5

* Covers with meter lids available upon request. See page 12 or page 57 for meter lid cover load rating explanation.
 * Total weight for 48" x 48" HA beam is 51 lbs (23 kg). Total weight for 48" x 48" HH tubing is 95 lbs (43 kg).

W6 X 12 WIDE FLANGE BEAM (FOR PG4848HA00 COVERS)
 6 X 4 TUBING (FOR PG4848HH00 COVERS)

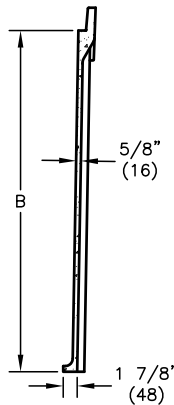
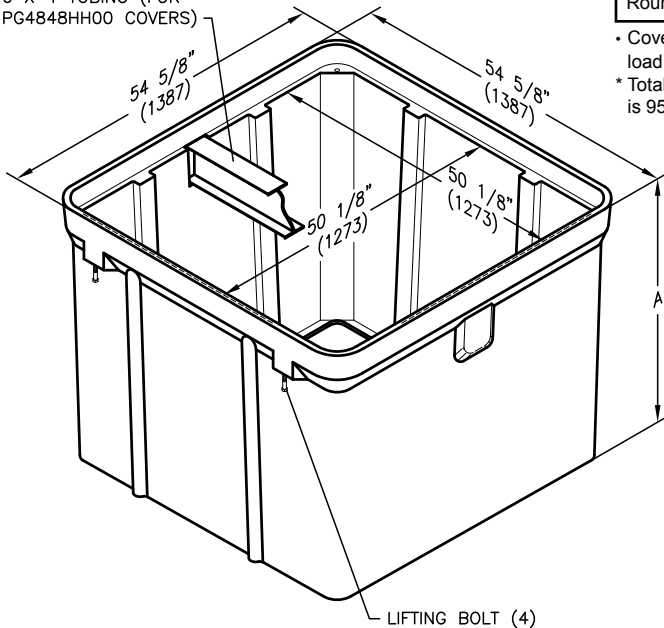

Boxes (Stackable with self-aligning, replaceable EZ-Nut)

DESCRIPTION	PART NO.	WEIGHT #	DIMENSION A	DIMENSION B	DESIGN/TEST LOAD #	ANSI TIER*
Open bottom	PG4848BA36	629 (285.0 kg)	36" (914 mm)	33" (838 mm)	22,500 / 33,750	22
	PG4848BA48	866 (393.0 kg)	48" (1219 mm)	45" (1143 mm)	22,500 / 33,750	22
Solid Bottom	PG4848DA36	663 (301.0 kg)	36 1/2" (927 mm)	33" (838 mm)	22,500 / 33,750	22
	PG4848DA48	940 (426.0 kg)	48 1/2" (1232 mm)	45" (1143 mm)	22,500 / 33,750	22

Dimensions & weights in parentheses are metric equivalent.
 * Loadings comply with ANSI/SCTE 77 (see page 9).



SPECIFICATIONS/DATA

48" x 72" PG Style (Stackable) Assembly

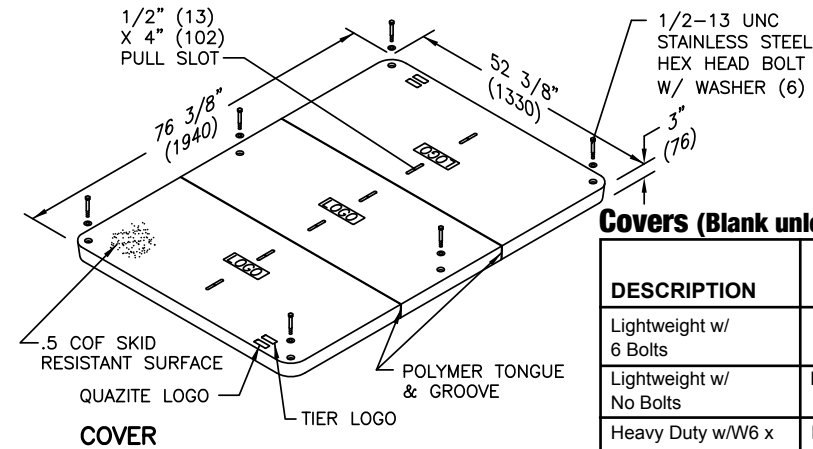

Covers (Blank unless logo is specified)

DESCRIPTION	PART NO.	WEIGHT #	DESIGN/TEST LOAD #	ANSI TIER*
Lightweight w/ 6 Bolts	LG4872CA00	447 (203.0 kg)	5,000 / 7,500	5
Lightweight w/ No Bolts	LG4872WA00	447 (203.0 kg)	5,000 / 7,500	5
Heavy Duty w/W6 x 12 Wide Flange Beam w/6 Bolts*	PG4872HA00	573 (260.0 kg)	15,000 / 22,500	15
Extra Heavy Duty w/ 6 x 4 Tubing w/6 Bolts*	PG4872HH00	891 (404.0 kg)	22,500 / 33,750	22

* Total weight for 48" x 72" HA beam is 102 lbs (46 kg). Total weight for 48" x 72" HH tubing is 190 lbs (86 kg).

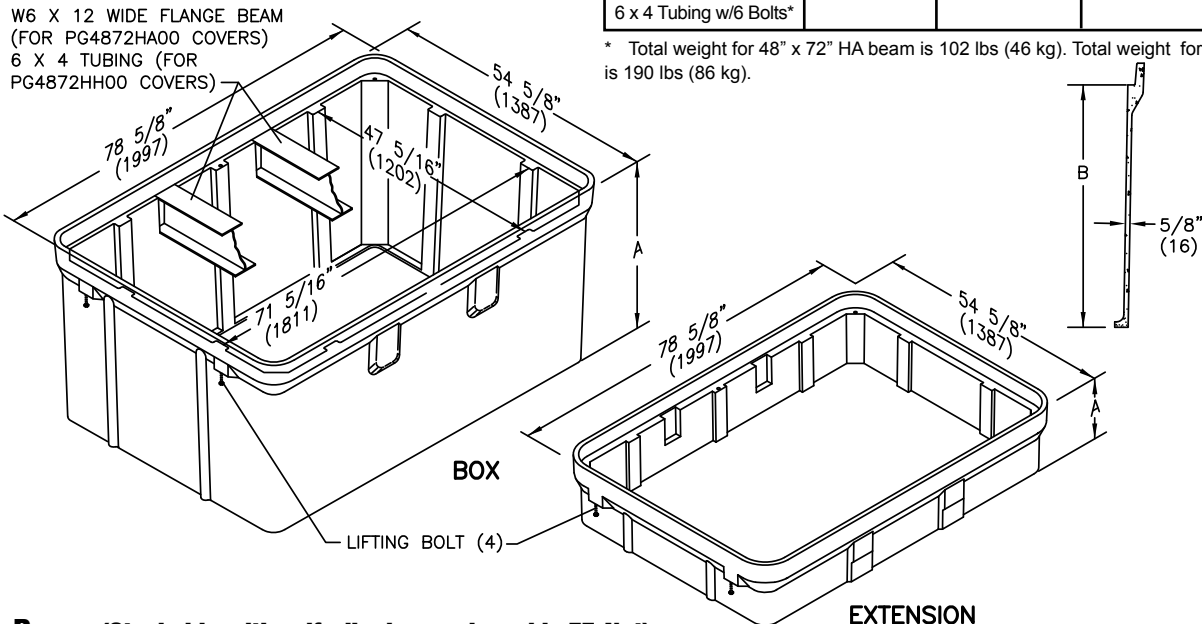

Boxes (Stackable with self-aligning, replaceable EZ-Nut)

DESCRIPTION	PART NO.	WEIGHT #	DIMENSION A	DIMENSION B	DESIGN/TEST LOAD #	ANSI TIER*
Open Bottom	PG4872BA36	810 (367.0 kg)	37 1/2" (953 mm)	33" (838 mm)	22,500 / 33,750	22
	PG4872BA48	1050 (476.0 kg)	49 1/2" (1257 mm)	45" (1143 mm)	22,500 / 33,750	22
Solid Bottom	PG4872DA36	1065 (483.0 kg)	36 1/2" (927 mm)	33" (838 mm)	22,500 / 33,750	22
	PG4872DA48	1245 (565.0 kg)	48 1/2" (1232 mm)	45" (1143 mm)	22,500 / 33,750	22

Extension (Stackable with self-aligning, replaceable EZ-Nut; for use on top of box only)

Top extensions are available to give extra depth.

DESCRIPTION	PART NO.	WEIGHT #	DIMENSION A	DIMENSION B	DESIGN/TEST LOAD #	ANSI TIER*
Open Bottom, Beam Pocket, No Beam Provided	PG4872EA12	359 (162.8 kg)	15" (381 mm)	12" (305 mm)	22,500 / 33,750	22

Dimensions & weights in parentheses are metric equivalent.

* Loadings comply with ANSI/SCTE 77 (see page 9).



SPECIFICATIONS/DATA

48" x 96" PG Style (Stackable) Assembly

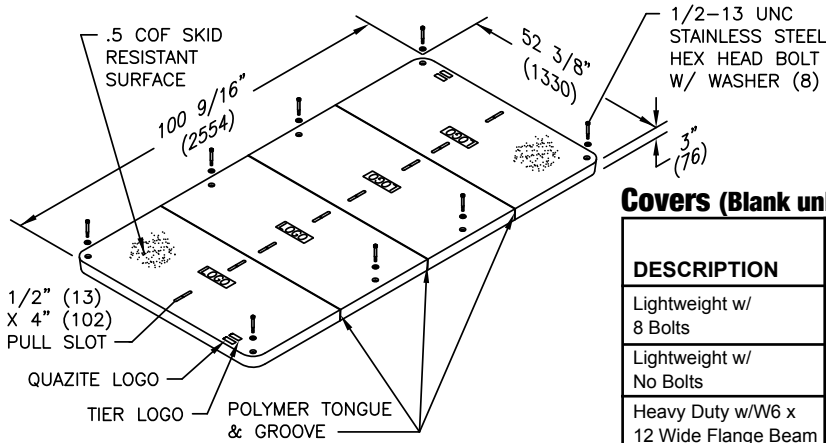

Covers (Blank unless logo is specified)

DESCRIPTION	PART NO.	WEIGHT #	DESIGN/TEST LOAD #	ANSI TIER*
Lightweight w/ 8 Bolts	LG4896CA00	608 (276.0 kg)	5,000 / 7,500	5
Lightweight w/ No Bolts	LG4896WA00	608 (276.0 kg)	5,000 / 7,500	5
Heavy Duty w/W6 x 12 Wide Flange Beam w/8 Bolts*	PG4896HA00	794 (360.0 kg)	15,000 / 22,500	15
Extra Heavy Duty w/ 6 x 4 Tubing w/8 Bolts*	PG4896HH00	1186 (538.0 kg)	22,500 / 33,750	22

* Total weight for 48" x 96" HA beam is 153 lbs (69 kg). Total weight for 48" x 96" HH tubing is 285 lbs (129 kg).

W6 X 12 WIDE FLANGE BEAM (FOR PG4896HA00 COVERS)
6 X 4 TUBING (FOR PG4896HH00 COVERS)

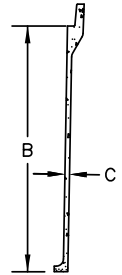
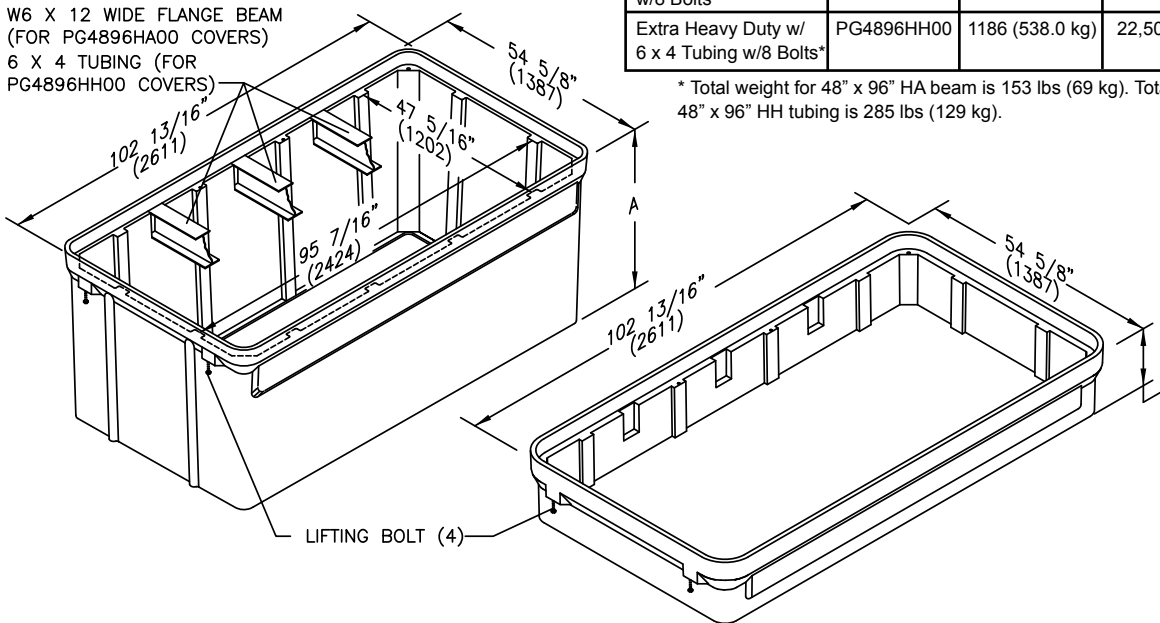

ENCLOSURE DRAWINGS

Boxes (Stackable with self-aligning, replaceable EZ-Nut)

DESCRIPTION	PART NO.	WEIGHT #	DIMENSION A	DIMENSION B	DIMENSION C	DESIGN/TEST LOAD #	ANSI TIER*
Open Bottom	PG4896BA48	1384 (628 kg)	49 3/4" (1264 mm)	45" (1143 mm)	5/8" (16 mm)	22,500 / 33,750	22
Solid Bottom	PG4896DA48	1537 (697 kg)	48 3/4" (1238 mm)	45" (1143 mm)	5/8" (16 mm)	22,500 / 33,750	22

Extension (Stackable with self-aligning, replaceable EZ-Nut; for use on top of box only)

Top extensions are available to give extra depth.

DESCRIPTION	PART NO.	WEIGHT #	DIMENSION A	DIMENSION B	DIMENSION C	DESIGN/TEST LOAD #	ANSI TIER*
Open Bottom, Beam Pocket, No Beam Provided	PG4896EA12	485 (220.0 kg)	15" (381 mm)	12" (305 mm)	1 1/16" (27 mm)	22,500 / 33,750	22

Dimensions & weights in parentheses are metric equivalent.

* Loadings comply with ANSI/SCTE 77 (see page 9).

SPECIFICATIONS/DATA

Grade Adjustable Extensions

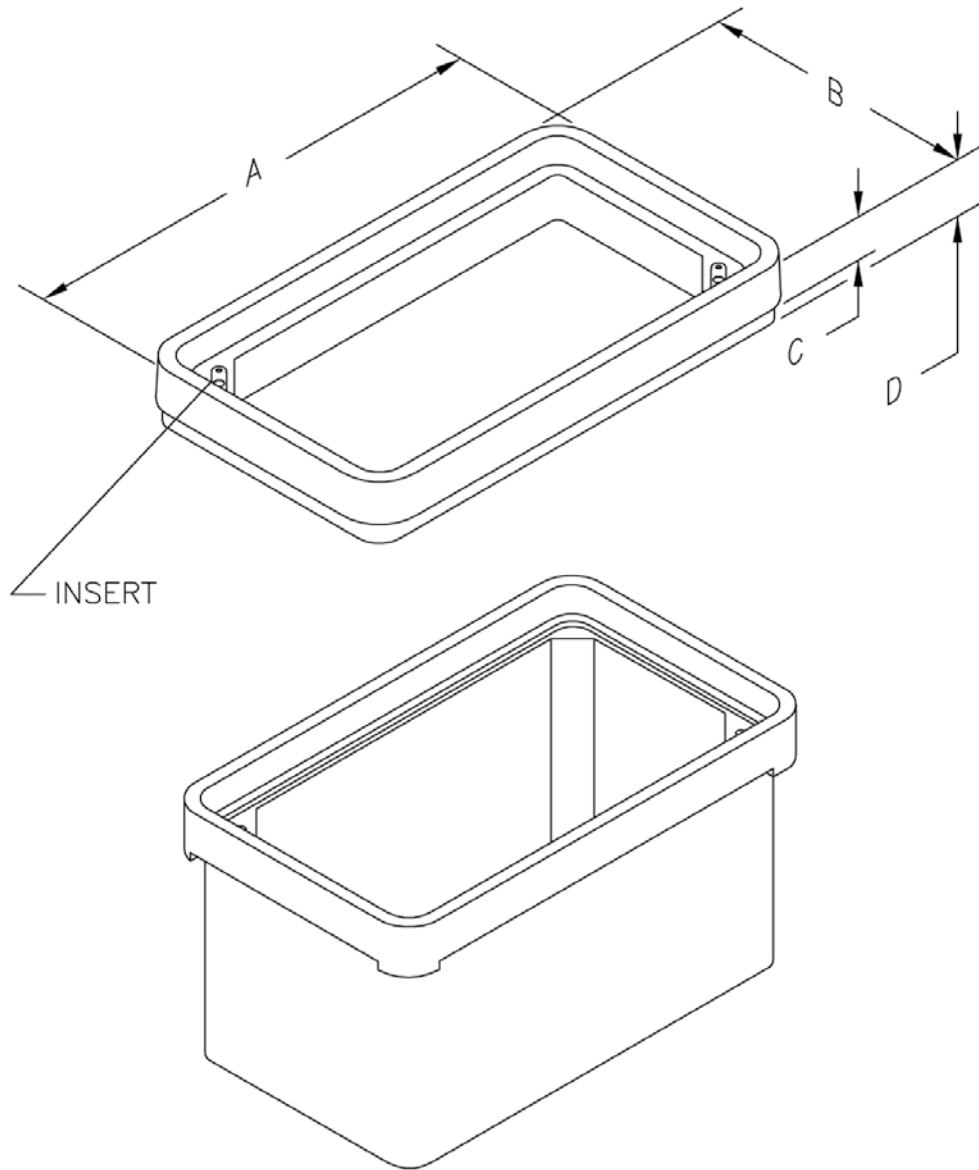

ENCLOSURE DRAWINGS

Grade Adjustable Extensions

PART NO.	WEIGHT #	DIMENSION A	DIMENSION B	DIMENSION C	DIMENSION D	INSERT SIZE	DESIGN/TEST LOAD #	ANSI TIER*
PG1324ED03	37 (16.8 kg)	25 1/2" (648 mm)	16" (406 mm)	3" (76 mm)	5 1/8" (130 mm)	1/2"	22,500 / 33,750	22
PG1324E502	37 (16.8 kg)	25 1/2" (648 mm)	16" (406 mm)	3" (76 mm)	5 1/8" (130 mm)	3/8"	22,500 / 33,750	22
PG1730ED03	48 (21.8 kg)	32 3/4" (832 mm)	19 3/4" (502 mm)	3" (76 mm)	5 1/8" (130 mm)	1/2"	22,500 / 33,750	22
PG1730E505	48 (21.8 kg)	32 3/4" (832 mm)	19 3/4" (502 mm)	3" (76 mm)	5 1/8" (130 mm)	3/8"	22,500 / 33,750	22
PG2436ED04	80 (36.3 kg)	37 7/8" (962 mm)	26 1/4" (667 mm)	4" (102 mm)	7 1/8" (181 mm)	1/2"	22,500 / 33,750	22
PG2436E503	80 (36.3 kg)	37 7/8" (962 mm)	26 1/4" (667 mm)	4" (102 mm)	7 1/8" (181 mm)	3/8"	22,500 / 33,750	22
PG3660ED03	110 (49.9 kg)	65 1/2" (1664 mm)	41 3/4" (1060 mm)	2 1/2" (64 mm)	4" (102 mm)	1/2"	22,500 / 33,750	22

Dimensions & weights in parentheses are metric equivalent.

* Loadings comply with ANSI/SCTE 77 (see page 9).



SPECIFICATIONS/DATA

27" Round Style (Nestable) Assembly

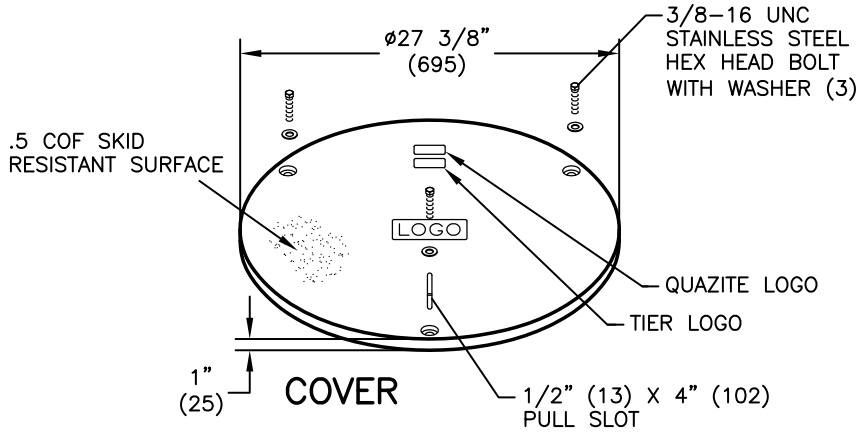

Covers (Blank unless logo is specified)

DESCRIPTION	PART NO.	WEIGHT #	DESIGN/TEST LOAD #	ANSI TIER*
Ⓛ W/3 Bolts	PR2700CA00	53 (24.0 kg)	8,000 / 12,000	8
Heavy Duty w/ 3 Bolts	PR2700HA00	75 (34.0 kg)	15,000 / 22,500	15
	PR2700HH00	75 (34.0 kg)	22,500 / 33,750	22

ENCLOSURE DRAWINGS

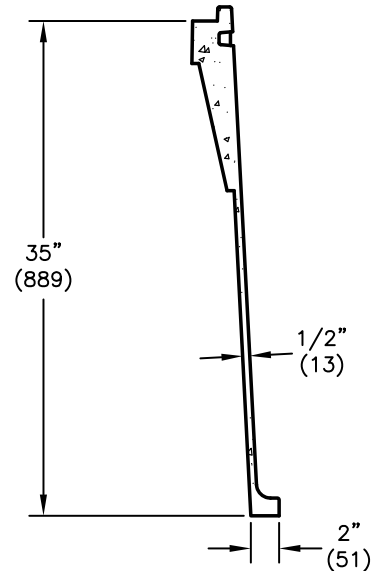
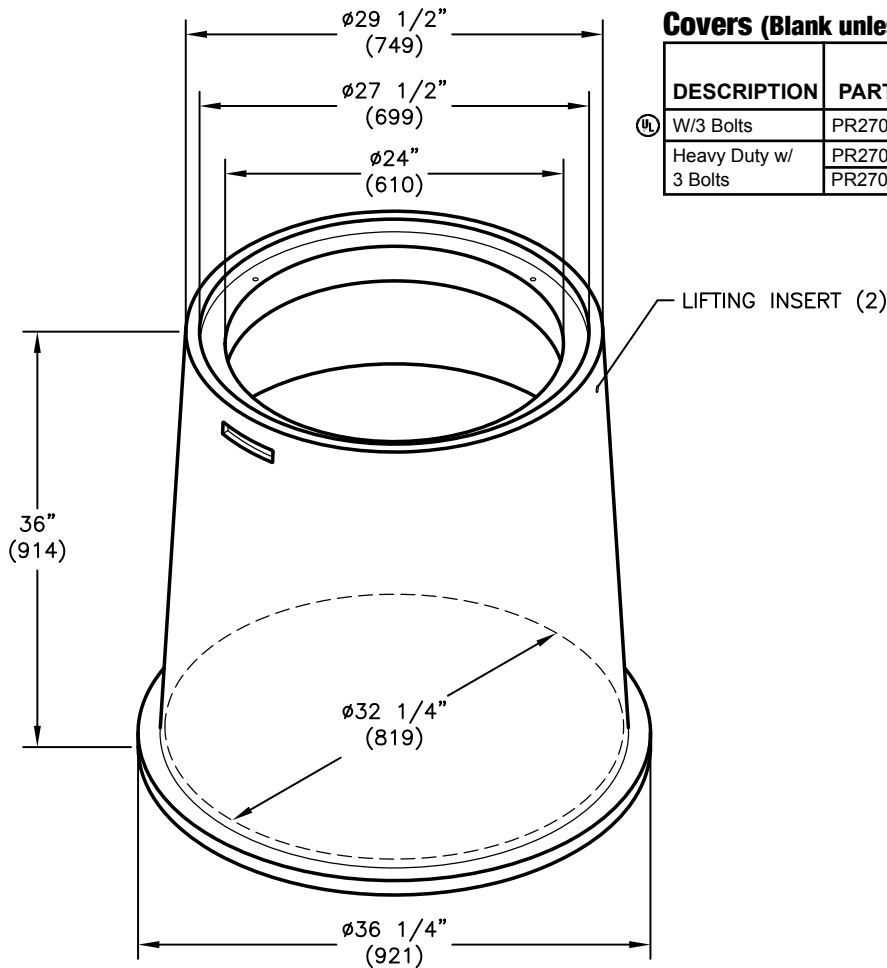

Boxes (Nestable)

DESCRIPTION	PART NO.	WEIGHT #	DESIGN/TEST LOAD #	ANSI TIER*
Ⓛ Open Bottom	PR2732BA36	278 (126.0 kg)	22,500 / 33,750	22

Dimensions & weights in parentheses are metric equivalent.

* Loadings comply with ANSI/SCTE 77 (see page 9).

SPECIFICATIONS/DATA

27" Round Style Assembly

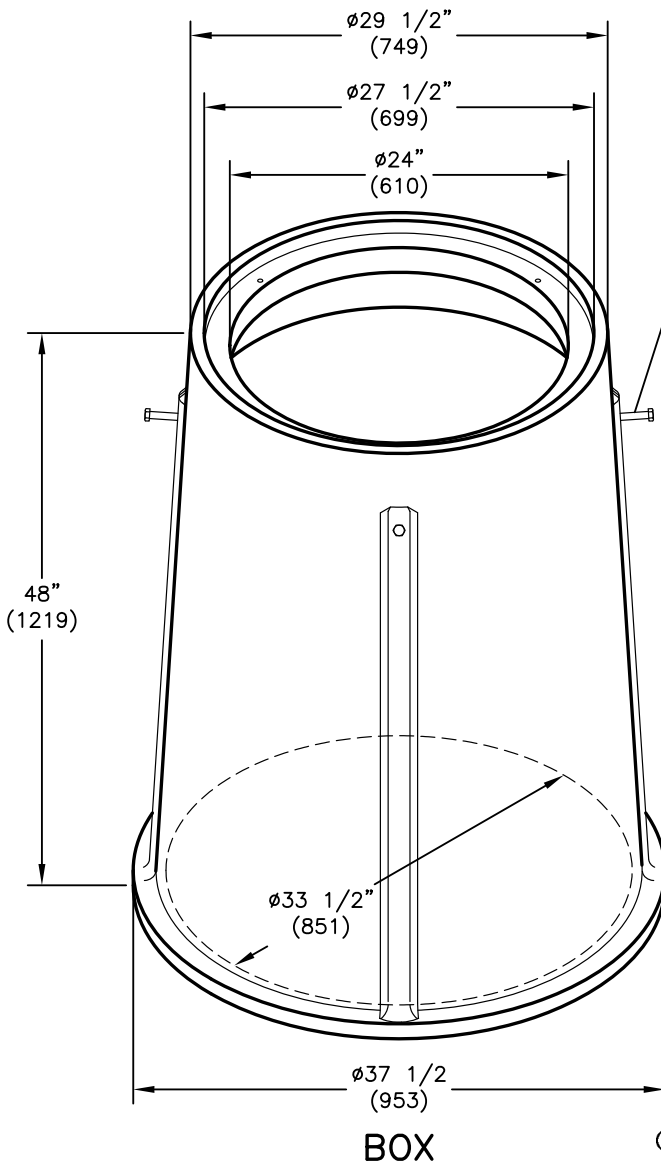
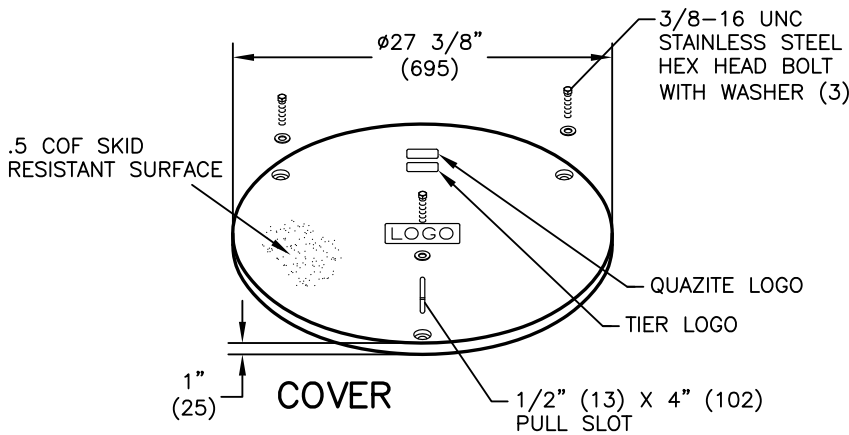

Covers (Blank unless logo is specified)

DESCRIPTION	PART NO.	WEIGHT #	DESIGN/TEST LOAD #	ANSI TIER*
W/3 Bolts	PR2700CA00	53 (24.0 kg)	8,000 / 12,000	8
Heavy Duty w/ 3 Bolts	PR2700HA00	75 (34.0 kg)	15,000 / 22,500	15
	PR2700HH00	75 (34.0 kg)	22,500 / 33,750	22

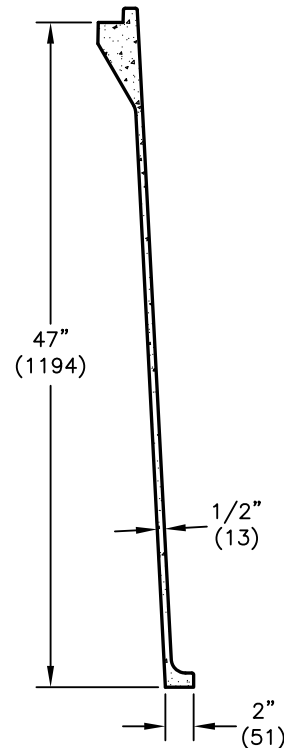

Boxes

DESCRIPTION	PART NO.	WEIGHT #	DESIGN/TEST LOAD #	ANSI TIER*
Open Bottom	PR2733BA48	283 (129.0 kg)	22,500 / 33,750	22

Dimensions & weights in parentheses are metric equivalent.
 * Loadings comply with ANSI/SCTE 77 (see page 9).



SPECIFICATIONS/DATA

39" Round Style (Nestable) Assembly

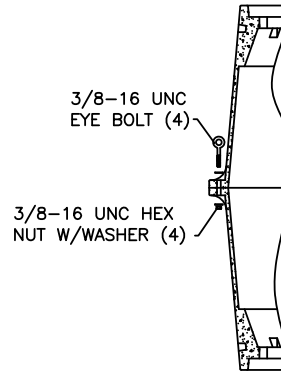
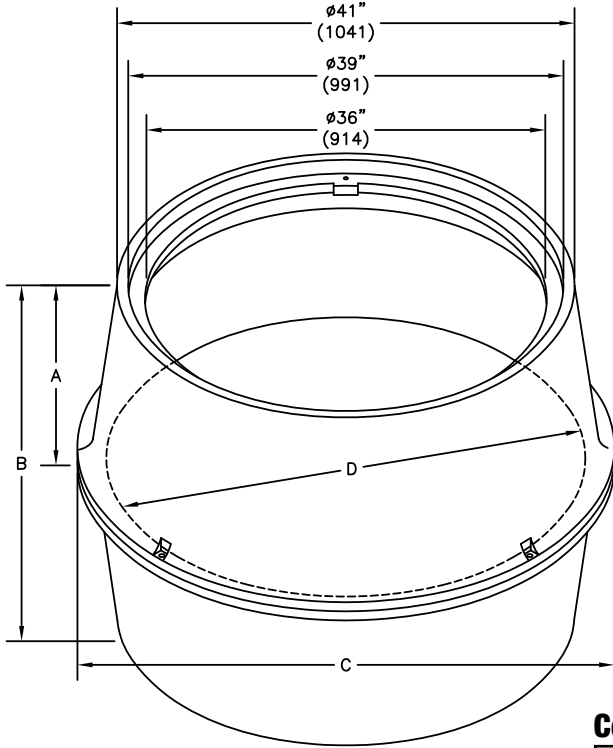
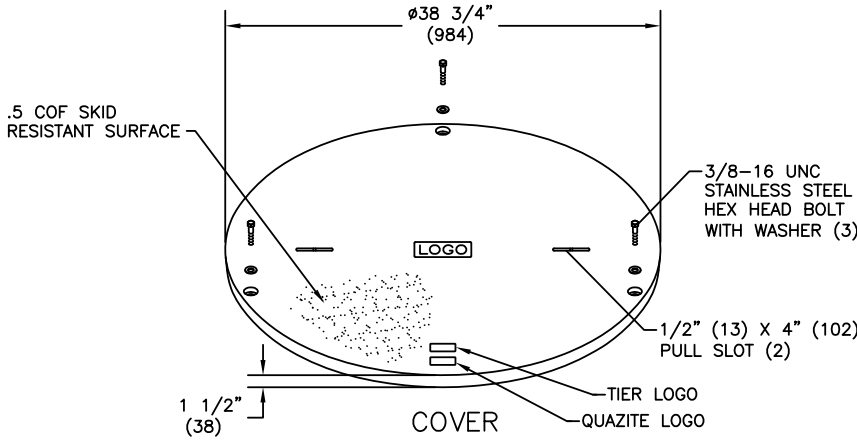

LIKE BOXES CAN BE INVERTED, STACKED, AND BOLTED TOGETHER TO INCREASE THE DEPTH

Covers (Blank unless logo is specified)

	DESCRIPTION	PART NO.	WEIGHT #	DESIGN/TEST LOAD #	ANSI TIER*
Ⓛ	W/3 Bolts	PR3900CA00	141 (64.0 kg)	8,000 / 12,000	8
Ⓛ	Heavy Duty w/ 3 Bolts	PR3900HA00	180 (81.6 kg)	15,000 / 22,500	15
Ⓛ	Heavy Duty w/ 3 Bolts	PR3900HH00	180 (81.6 kg)	22,500 / 33,750	22

Boxes (Nestable)

	DESCRIPTION	PART NO.	WEIGHT #	DIMENSION A	DIMENSION B	DIMENSION C	DIMENSION D	DESIGN/TEST LOAD #	ANSI TIER*
Ⓛ	Open Bottom	PR3943BA18	244 (111.0 kg)	18" (457 mm)	-	48 1/8" (1222 mm)	43 1/8" (1095 mm)	22,500 / 33,750	22
Ⓛ		PR3944BA24	326 (147.9 kg)	24" (610 mm)	-	49 3/16" (1249 mm)	44 3/16" (1122 mm)	22,500 / 33,750	22
Ⓛ	Open Bottom	PR3943BA36	488 (221.0 kg)	-	36" (914 mm)	48 1/8" (1222 mm)	43 1/8" (1095 mm)	22,500 / 33,750	22

Dimensions & weights in parentheses are metric equivalent.

* Loadings comply with ANSI/SCTE 77 (see page 9).

SPECIFICATIONS/DATA

39" Round Style Assembly

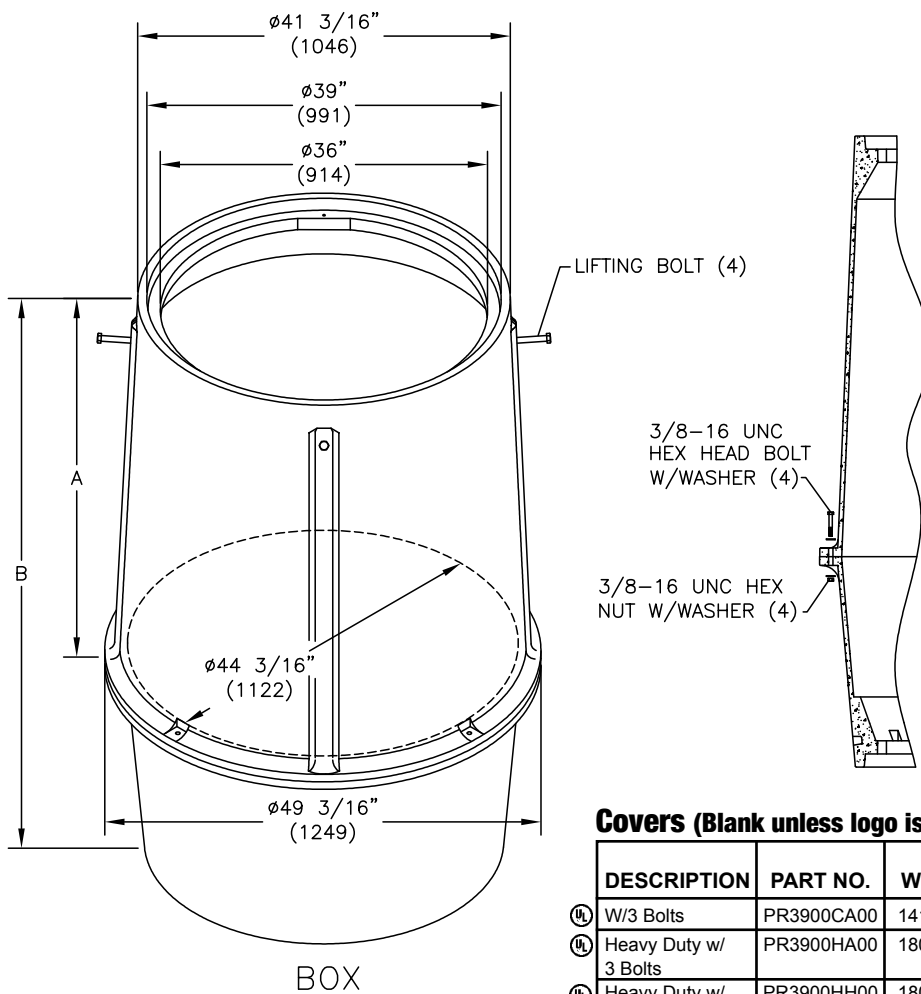
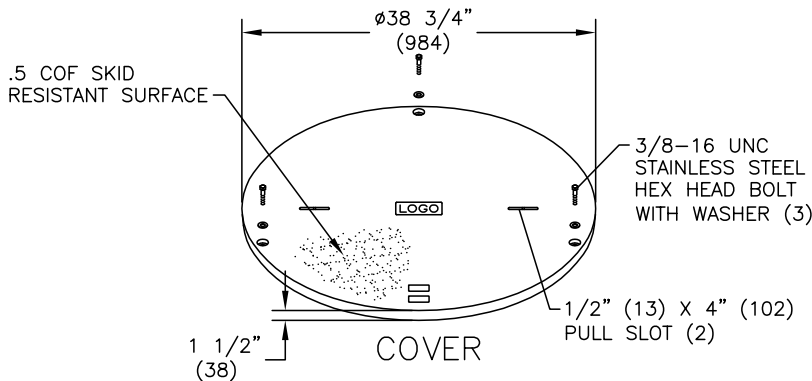

Covers (Blank unless logo is specified)

DESCRIPTION	PART NO.	WEIGHT #	DESIGN/TEST LOAD #	ANSI TIER*
Ⓛ W/3 Bolts	PR3900CA00	141 (64.0 kg)	8,000 / 12,000	8
Ⓛ Heavy Duty w/ 3 Bolts	PR3900HA00	180 (81.6 kg)	15,000 / 22,500	15
Ⓛ Heavy Duty w/ 3 Bolts	PR3900HH00	180 (81.6 kg)	22,500 / 33,750	22

Boxes

DESCRIPTION	PART NO.	WEIGHT #	DIMENSION A	DIMENSION B	DESIGN/TEST LOAD #	ANSI TIER*
Ⓛ Open Bottom	PR3944BA48	377 (171.0 kg)	48" (1219 mm)	-	22,500 / 33,750	22
Ⓛ Open Bottom	PR3944BA72	707 (321 kg)	-	72 (1829 mm)	22,500 / 33,750	22

Dimensions & weights in parentheses are metric equivalent.

* Loadings comply with ANSI/SCTE 77 (see page 9).



ENCLOSURE DRAWINGS

SPECIFICATIONS/DATA

Replacement Covers

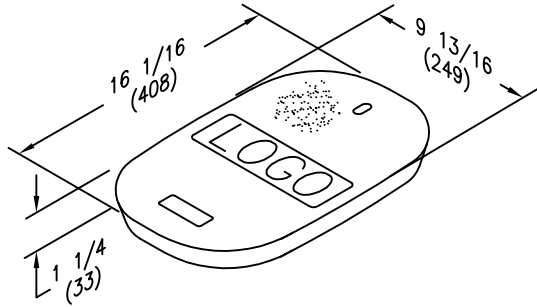

PG0915WAS0
13# (5.9 kg)

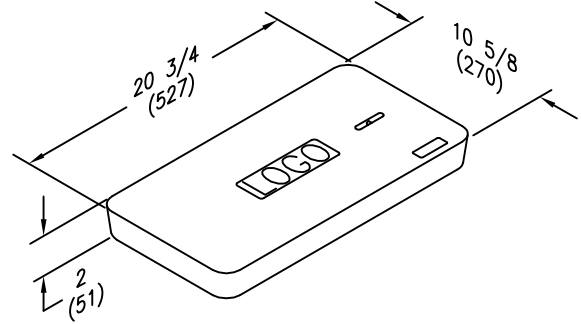

PG1121WA00
33# (15.0 kg)

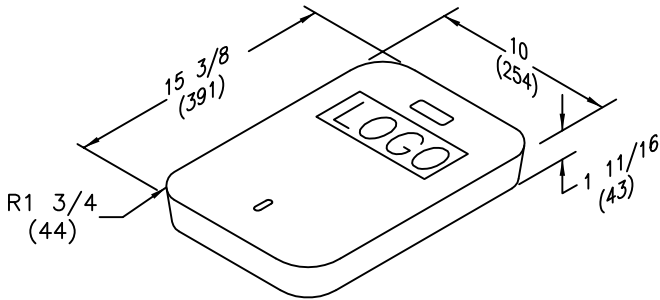

PG1015WAS0
20# (9.0 kg)

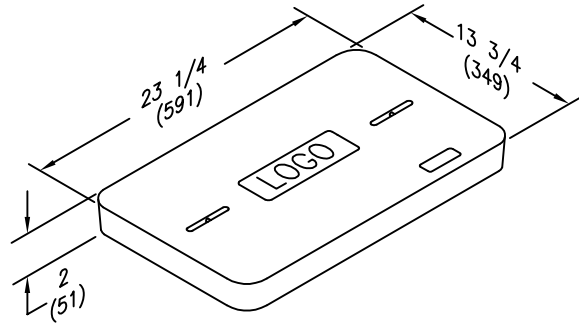

PG1324WA00
32# (14.5 kg)

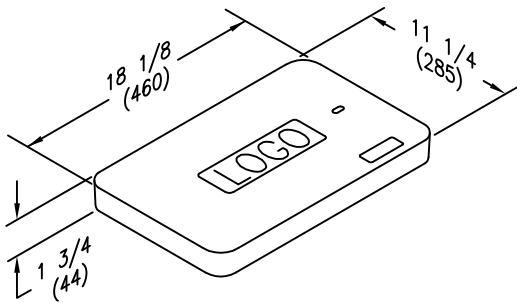

PG1118WAS0
27# (12.3 kg)

All covers have a .5 COF skid resistant surface.
Dimensions & weights in parentheses are metric equivalent.

COVER DRAWINGS

SPECIFICATIONS/DATA

Replacement Covers

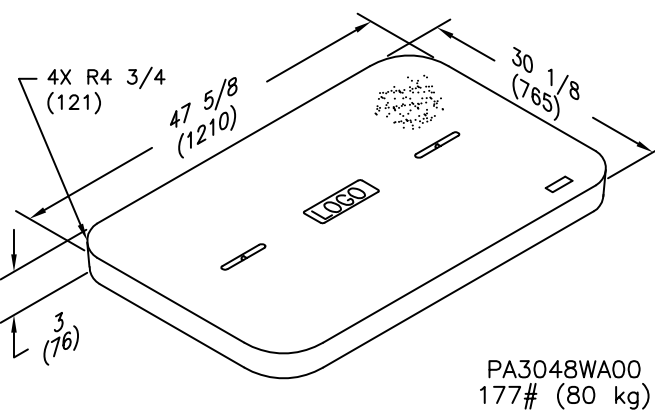
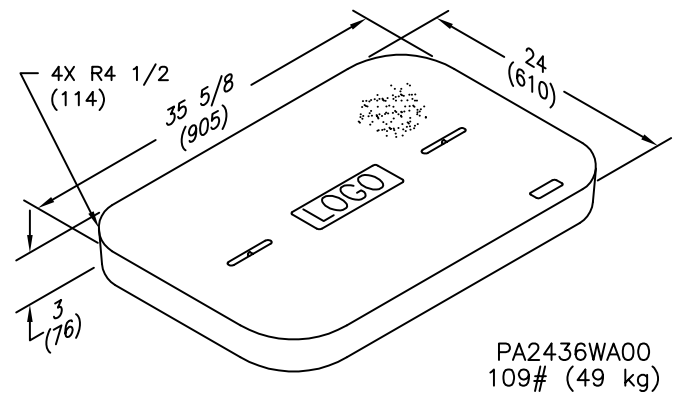
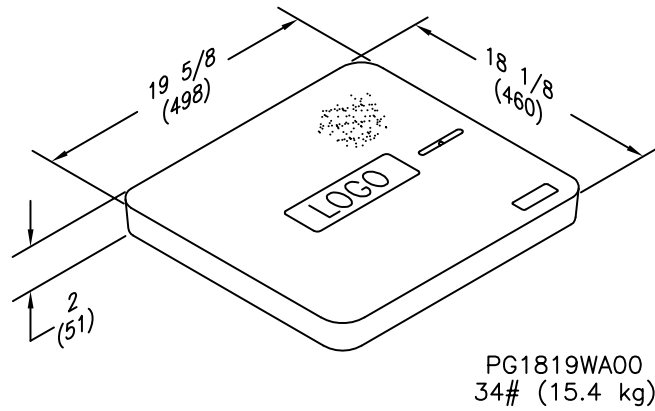
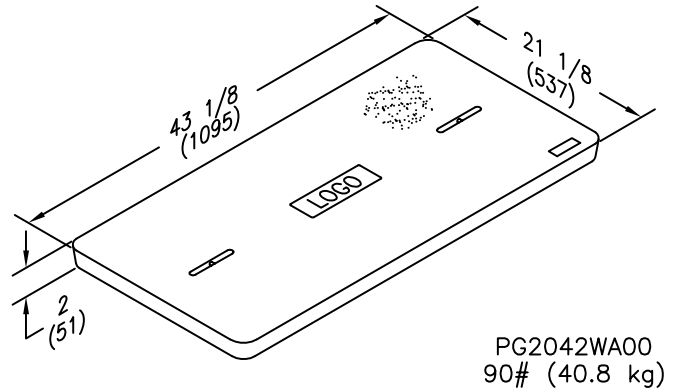
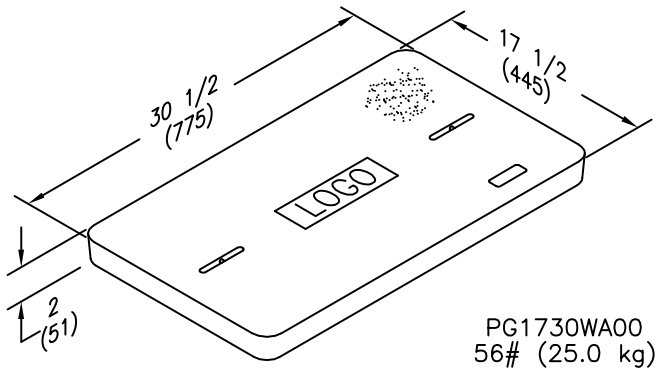

COVER DRAWINGS



All covers have a .5 COF skid resistant surface.
Dimensions & weights in parentheses are metric equivalent.

JANUARY 2011

SPECIFICATIONS/DATA

Replacement Covers

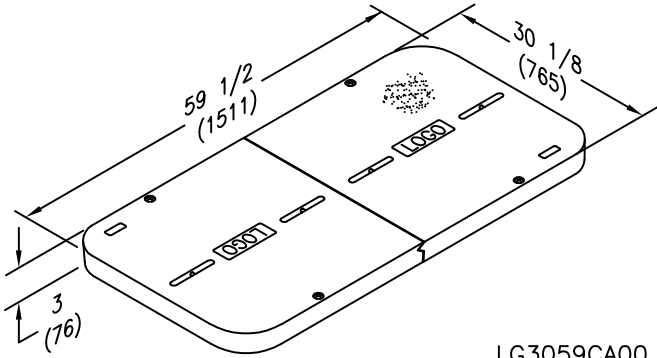

LG3059CA00
128# (58 kg)

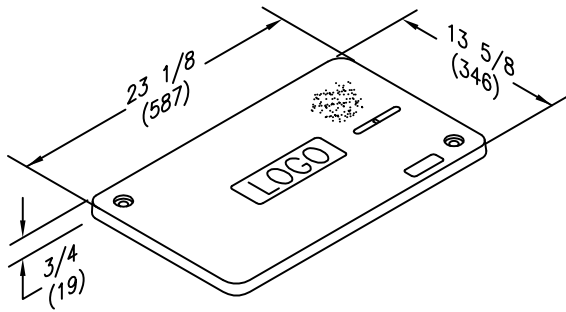

PX1324CA00
18# (8.2 kg)

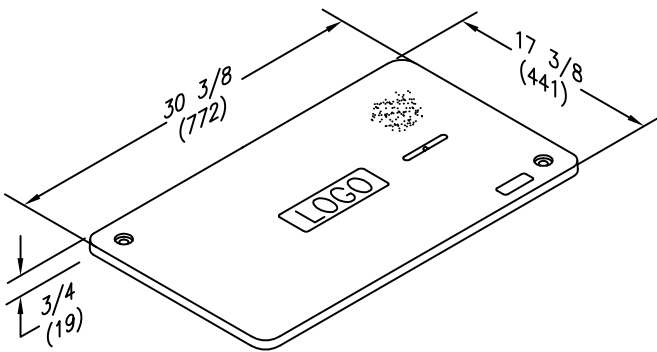

PX1730CA00
34# (15.4 kg)

COVER DRAWINGS

SPECIFICATIONS/DATA

Meter Reading Covers and Lids

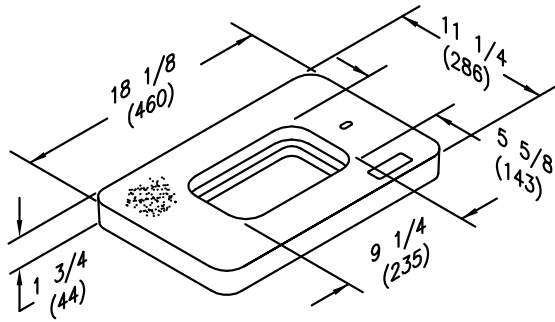

PG1118WAKOA
22# (10.0 kg)

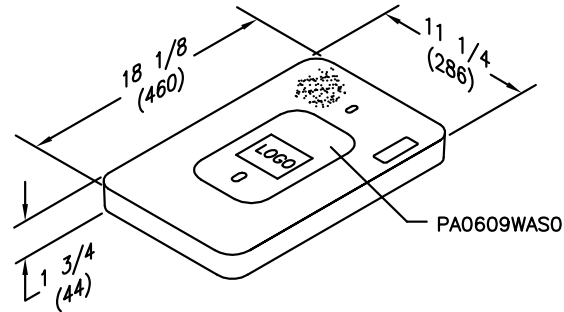

PG1118WAKO
27# (12.3 kg)

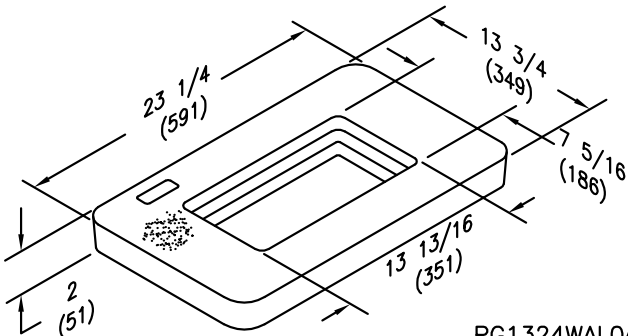

PG1324WALOA
34# (15.4 kg)

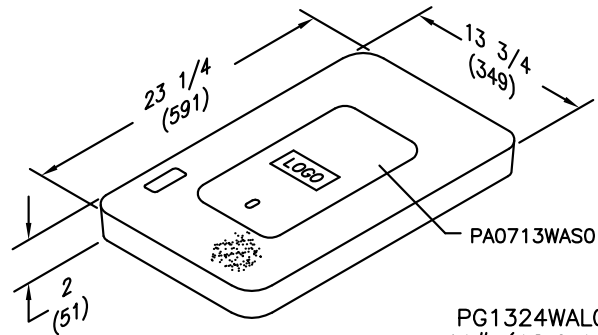

PG1324WALO
41# (18.6 kg)

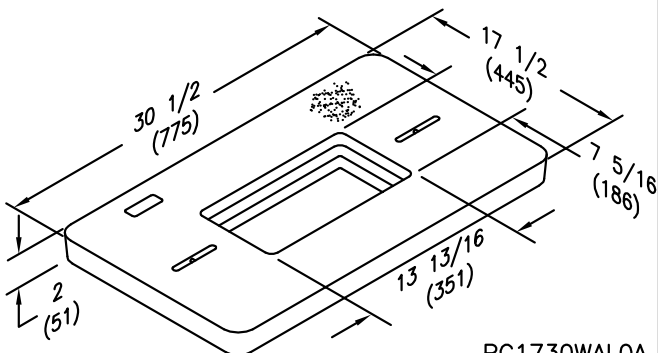

PG1730WALOA
67# (30.4 kg)

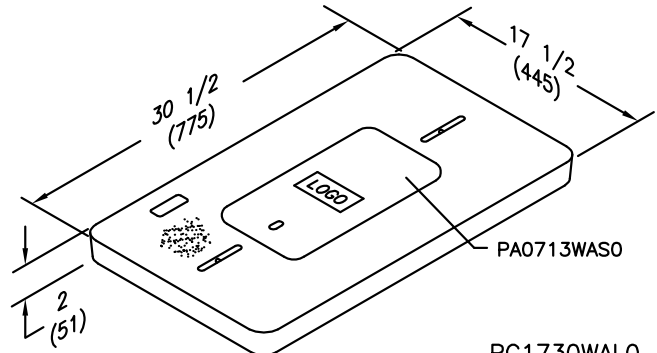

PG1730WALO
74# (33.6 kg)

DROP IN LID

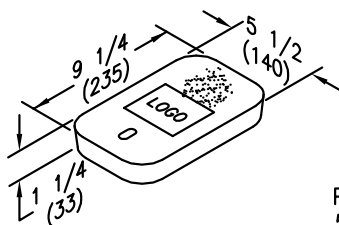

PA0609WASO
5# (2.3 kg)

DROP IN LID

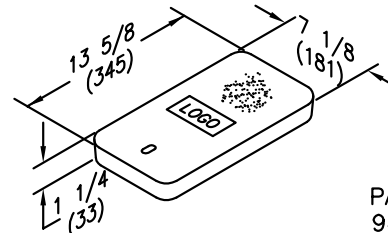

PA0713WASO
9# (4.1 kg)

COVER DRAWINGS

Adding a meter lid to a Tier 8 cover reduces the rating to Tier 5. A Tier 5 cover will be reduced to a pedestrian traffic only rating.

SPECIFICATIONS/DATA

Hardware

Standard Hex-Head Bolt - Stainless Steel

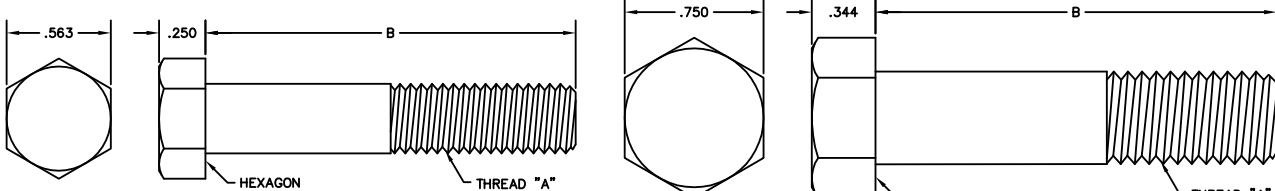

Thread (A)	(B)	Part No.	UPC # 66-237	Cover Application
3/8-16 UNC	1.50"	80008	13162	PC0608, PC0818 PC1012, PC1118 PC1212, PC1324 PC1730, PX1324 PX1730
3/8-16 UNC	1.75"	80009	13163	PR2700, PR3900
3/8-16 UNC	2.50"	80012	13411	PG1015, PG1118
3/8-16 UNC	2.75"	80013	13165	PG2424, PT1324 PT1730
3/8-16 UNC	3.00"	80036	13174	PD1324, PD1730 PG1324, PG1730
3/8-16 UNC	4.00"	80018	13166	PD2436, PD3048, PG2436, PG3048 PG3636
3/8-16 UNC	4.50"	80017	13421	PG3048 (Overlapping)

Thread (A)	(B)	Part No.	UPC # 66-237	Cover Application
1/2-13 UNC	1.75"	80107	13167	LG3660
1/2-13 UNC	3.50"	80114	13169	PG3660 (Overlapping)
1/2-13 UNC	4.00"	80119	13176	PG3060, PG3672 PG4848, PG4872 PG4896
1/2-13 UNC	5.00"	80108	13175	PG3060 (Overlapping)

Tamper Resistant Standard Penta-Head Bolt - Stainless Steel

(For use with penta-head socket #82922)

(For use with penta-head socket #82920)

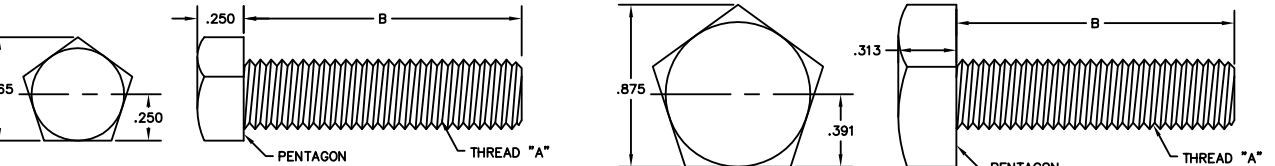

Thread (A)	(B)	Part No.	UPC # 66-237	Cover Application
3/8-16 UNC	1.50"	80024	12996	PC0608, PC0818, PC1012, PC1118, PC1212, PX1212
3/8-16 UNC	2.00"	80048	15619	PC0808

Thread (A)	(B)	Part No.	UPC # 66-237	Cover Application
3/8-16 UNC	1.50"	80023	12994	PC1324, PC1730, PX1324 PX1730
3/8-16 UNC	1.75"	80022	12940	PR2700, PR3900
3/8-16 UNC	2.50"	80026	13008	PG1015, PG1118
3/8-16 UNC	2.75"	80027	11837	PG2424, PT1324, PT1730
3/8-16 UNC	3.00"	80028	13009	PD1324, PD1730, PG1324, PG1730
3/8-16 UNC	4.00"	80032	12995	PD2436, PD3048, PG2436, PG3048, PG3636
3/8-16 UNC	4.50"	80031	13006	PG3048 (Overlapping)
1/2-13 UNC	1.75"	80122	13177	LG3660
1/2-13 UNC	3.50"	80129	11840	PG3660 (Overlapping)
1/2-13 UNC	4.00"	80131	13161	PG3060, PG3672, PG4848 PG4872, PG4896
1/2-13 UNC	5.00"	80132	13178	PG3060 (Overlapping)

Cover Hook - Electroplated Steel

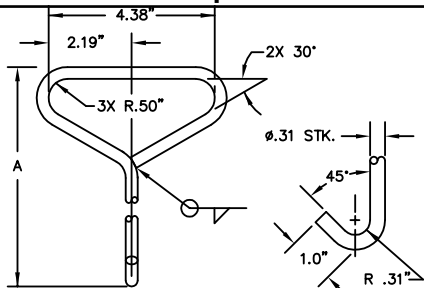

Description	Part No.	UPC# 66-237	(A)
Short Cover Hook	82905	11842	7.0"
Long Cover Hook	82908	11843	27.0"

Tamper Resistant Standard Penta-Head Socket - Alloy Steel

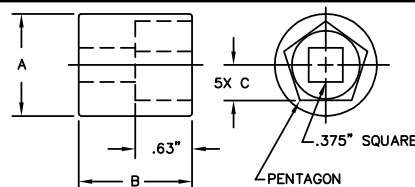

Part No.	UPC # 66-237	(A)	(B)	(C)
82920	11844	1.13"	2.00"	.391"
82922	11845	.88"	1.50"	.250"
82924	11846	.50"F to .375"M Adapter		



Hubbell's **NEW** "Self-Cleaning Auger Bolt Assembly" (Each assembly includes 2 bolts, 2 nuts and 2 washers)

This **NEW** "Self-Cleaning Auger Bolt Assembly" aggressively digs and bores through compacted dirt, stone and debris, forcing the dirt out through the drain hole to ensure covers may easily be reinstalled and secured to the enclosure after backfilling or extended installation. This assembly is recommended for use as a replacement (see installation instructions on page 95 of the Quazite® bolt and nut or in new installations.

To order this option, add the suffix "H" to BOTH the box and cover part numbers (Ex. PG2436BA24H & PG2436HA0017H.)

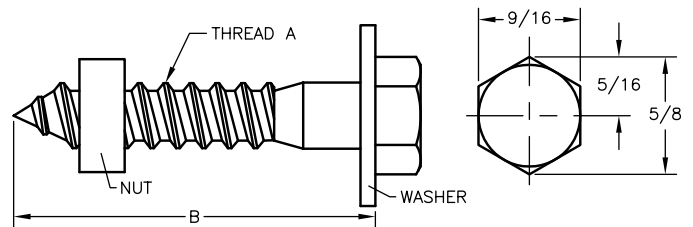

Thread (A)	B	Part No.	UPC# 66-2037	Cover Application
3/8-7 Lag Thread	2.00"	82500	12861	PC0608, PC0818, PC1012, PC1118, PC1212, PC1324, PC1730, PX1324, PX1730
3/8-7 Lag Thread	3.50"	82505	12862	PG1324, PG1730
3/8-7 Lag Thread	4.00"	82510	12863	PG2436, PG3048, PG3636

New Secure Cover Lockdown Option

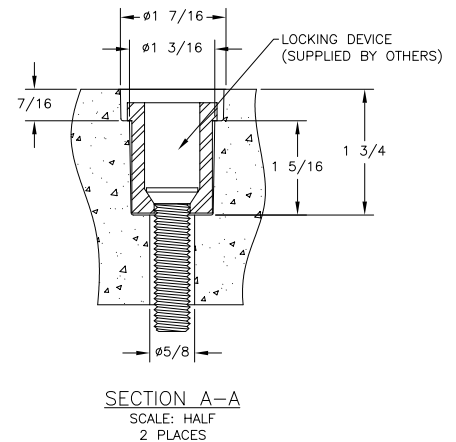
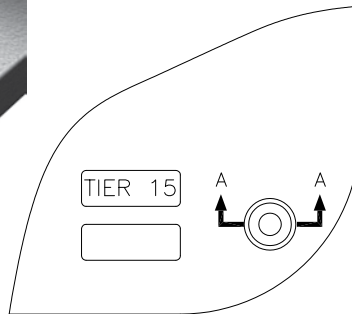

Hubbell now offers a unique counterbore design which allows easy installation of a LockDown-LockDry handhole locking device (sold separately). To order this option, insert the letter "D" into the 9th digit of the cover part number (Ex. PG3048HAD009). This option is available for PD, PG, & PT style covers 11" x 18" and larger

For more information on the locking device, visit <http://www.lockdown-lockdry.com/lockout.php>.

SPECIFICATIONS/DATA

Options

Holes

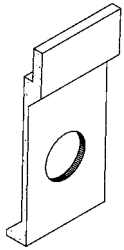

Conduit Sizes
(For actual hole sizes and locations see page 58.)

- 2"
- 3"
- 4" Electrical
- 4" Telephone
- 5"
- 6"

Other hole sizes available. Contact your local QUAZITE® representative for additional sizes.

Special order boxes with holes (or mouseholes, etc.) may qualify for UL Listing as long as the holes do not exceed more than 25% of the area of each sidewall and as long as the holes do not cut into a structural reinforcing rib, corner, or box lip.

Knockouts

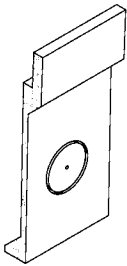

Conduit Sizes
(For actual hole sizes and locations see page 58.)

- 2"
- 3"
- 4" Electrical
- 4" Telephone
- 5"
- 6"

Other knockout sizes available. Contact your local QUAZITE® representative for additional sizes.

Special order boxes with holes (or mouseholes, etc.) may qualify for UL Listing as long as the holes do not exceed more than 25% of the area of each sidewall and as long as the holes do not cut into a structural reinforcing rib, corner, or box lip.

Terminators

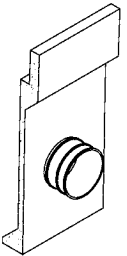

Conduit Sizes
(For actual hole sizes and locations see page 58.)

- 2"
- 3"
- 4" (Electrical & Telephone)*
- 5"
- 6"

*New 4" terminator design accommodates both electrical and telephone conduit sizes. Other terminator sizes available. Contact your local QUAZITE® representative for additional sizes.

Special order boxes with holes (or mouseholes, etc.) may qualify for UL Listing as long as the holes do not exceed more than 25% of the area of each sidewall and as long as the holes do not cut into a structural reinforcing rib, corner, or box lip.

Strut Racks



Box and cover struts available. Contact your local QUAZITE® representative for sizes.

Inserts must be located in ribs. See page 58 for rib locations.

Width x Depth
1-5/8" x 1-5/8"

Cable Racks & Rack Hooks - Galvanized Steel

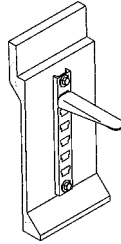

Cable Racks available in the following lengths:

12" length	80911
18" length	80910
24" length	80915
30" length	80920
36" length	80921

See page 58 for cable rack locations.

Cable Rack Hooks **Part No.**

7-1/2" length	80905
10" length	80907

Pulling Eyes

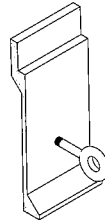

Available Ratings

- 1,500 lbs.
- 3,000 lbs.
- 10,000 lbs.

Electronic Markers (cast in cover)

Full Range Electronic Markers are encased in the polymer concrete cover for protection. Specify power, gas, sanitary water or telephone as each type of utility has a different signal for identification.

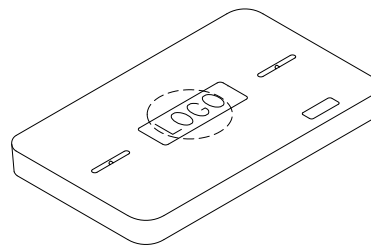

Marker	Frequency
Telephone	101.4 kHz
Power	169.8 kHz
Gas	83.0 kHz
Water	145.7 kHz
Sanitary	121.6 kHz

Captive Bolts

Captive bolts are available for PC, PD, PG, LG, PT, LT and PR style covers. Captive bolts prevent the bolt from falling out of the cover when the cover is removed.

SPECIFICATIONS/DATA

Options

Bolt Holes

Sizes
 3/8"
 1/4"
 1/2"

Inserts - 18-8 Stainless Steel

Available Sizes
 3/8" or 1/2"

Inserts must be located in ribs. See page 58 for rib locations.

Mouseholes

There is no additional charge for mouseholes in the standard size and location for their respective enclosures. PC0608, PC0818 and PC1212 boxes usually do not have mouseholes. See pg. 58 for locations.

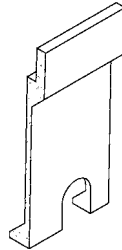

Mousehole Sizes Standard on Boxes

2-1/2" x 4"	LT1015, PC1118, PG1118
4" x 4"	PC1324, PT1324, PC1730, PT1730, PG1324, PG2424, PG1730, PD1730, PG2436, PG3048, PD3048, PG3636
6" x 8"	PG3060, PG3660, PG3672, PG4848, PG4872, PG4896

Mousehole Knockouts

There is no additional charge for mousehole knockouts in the standard size and location for their respective enclosures. Contact your local QUAZITE® representative for size options. See pg. 58 for locations.

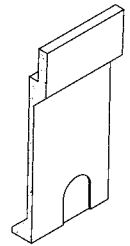

Special order boxes with holes (or mouseholes, etc.) may qualify for UL Listing as long as the holes do not exceed more than 25% of the area of each sidewall and as long as the holes do not cut into a structural reinforcing rib, corner, or box lip.

Other sizes available. Contact your local QUAZITE® representative for information.

Hinged Meter Lids*

Available Sizes

- R - Cast iron 4 1/2" x 7 1/2" lid
- P - Cast iron 6" x 9" lid
- Q - Cast iron 9" x 12" lid with frame

*Adding a meter lid to a Tier 8 cover reduces the rating to Tier 5. A Tier 5 cover will be reduced to a pedestrian traffic only rating.

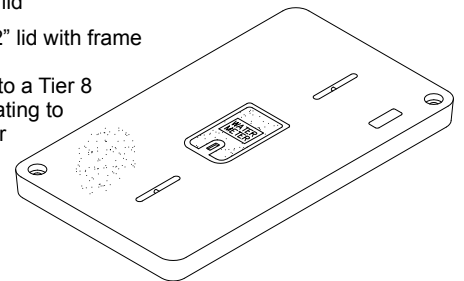

Pull Slots

The standard cover pull slot measures 1/2" x 4". Bell cover pull slots measuring 1" x 4" are available upon request.

Drop-in Meter Lids*

Available Sizes

- K - Polymer concrete 6" x 9" drop-in lid
- L - Polymer concrete 7" x 13" drop-in lid

*Adding a meter lid to a Tier 8 cover reduces the rating to Tier 5. A Tier 5 cover will be reduced to a pedestrian traffic only rating.

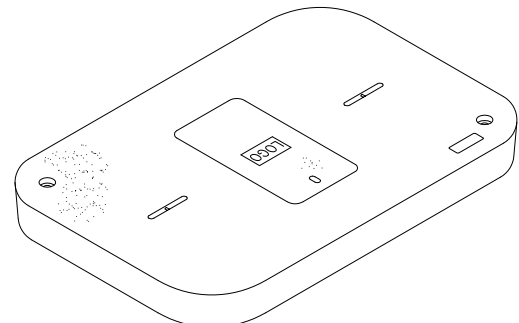

SPECIFICATIONS/DATA Standard Cable Rack Insert, Terminator, Knockout & Hole Locations

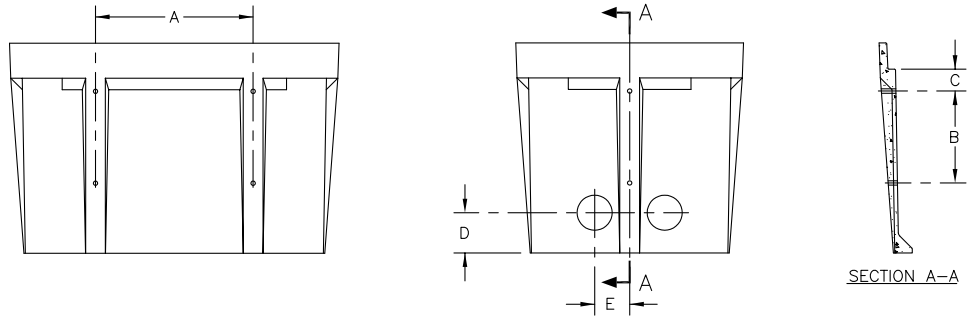

Mouseholes (not illustrated) - The standard location for mouseholes is in the center of the end walls of the enclosure.

BOXES

PART NO.	DIMENSIONS				
	A	B	C	D	E
PG2424BA24	12" (305 mm)	10 1/2" (267mm)	4" (102 mm)	5 1/2" (140mm)	4" (102mm)
PG2436BA18	18" (457mm)	9" (229mm)	2 1/2" (64 mm)	5 1/2" (140mm)	4" (102mm)
PG2436BA24	18" (457mm)	13 1/2" (343mm)	2 1/2" (64 mm)	5 1/2" (140mm)	4" (102mm)
PG2436BA30	18" (457mm)	13 1/2" (343mm)	2 1/2" (64 mm)	5 1/2" (140mm)	4" (102mm)
PG2436BA42	18" (457mm)	13 1/2" (343mm)	2 1/2" (64 mm)	5 1/2" (140mm)	4" (102mm)
PD3048BA24	22" (559mm)	10 1/2" (267mm)	6" (152 mm)	5 1/2" (140mm)	5 1/2" (140mm)
PD3048BA48	22" (559mm)	13 1/2" (343 mm)	6" (152 mm)	5 1/2" (140mm)	5 1/2" (140mm)
PG3048BA18	22" (559mm)	9" (229mm)	2 1/2" (64 mm)	5 1/2" (140mm)	5 1/2" (140mm)
PG3048BA24	22" (559mm)	10 1/2" (267mm)	2 1/2" (64 mm)	5 1/2" (140mm)	5 1/2" (140mm)
PG3048BA36	22" (559mm)	13 1/2" (343mm)	2 1/2" (64 mm)	5 1/2" (140mm)	5 1/2" (140mm)
PG3060BA21	20 3/4" (527mm)	10 1/2" (267mm)	2 1/2" (64 mm)	5 1/2" (140mm)	7" (178mm)
PG3060BA30	24" (610mm)	10 1/2" (267mm)	2 1/2" (64 mm)	5 1/2" (140mm)	7" (178mm)
PG3060BA36	20 3/4" (527mm)	10 1/2" (267mm)	2 1/2" (64 mm)	5 1/2" (140mm)	7" (178mm)
PG3636BA36	18" (457mm)	13 1/2" (343mm)	2 1/2" (64 mm)	5 1/2" (140mm)	7" (178mm)
PG3660BA19	22" (559mm)	10 1/2" (267mm)	4" (102 mm)	5 1/2" (140mm)	9" (229mm)
PG3660BA24	22" (559mm)	10 1/2" (267mm)	4" (102 mm)	5 1/2" (140mm)	9" (229mm)
PG3660BA31	22" (559mm)	10 1/2" (267mm)	4" (102 mm)	5 1/2" (140mm)	9" (229mm)
PG3660BA36	22" (559mm)	10 1/2" (267mm)	4" (102 mm)	5 1/2" (140mm)	9" (229mm)
PG3672BA21	20" (508mm)	10 1/2" (267mm)	3" (76 mm)	5 1/2" (140mm)	9" (229mm)
PG3672BA36	20" (508mm)	10 1/2" (267mm)	3" (76 mm)	5 1/2" (140mm)	9" (229mm)
PG4848BA36	22" (559mm)	10 1/2" (267mm)	5 1/2" (140 mm)	7" (178mm)	5 1/2" (140mm)
PG4848BA48	22" (559mm)	10 1/2" (267mm)	5 1/2" (140 mm)	7" (178mm)	5 1/2" (140mm)
PG4872BA36	46" (1168mm)	13 1/2" (343mm)	5 1/2" (140 mm)	7" (178mm)	5 1/2" (140mm)
PG4872BA48	46" (1168mm)	13 1/2" (343mm)	5 1/2" (140 mm)	7" (178mm)	5 1/2" (140mm)
PG4896BA48	24 3/16" (614mm)	13 1/2" (343mm)	5 1/2" (140 mm)	7" (178mm)	5 1/2" (140mm)

NOTE - Holes should be located only in the walls of an enclosure. Do not cut holes in ribs or corners. Hole locations are ± 1" (25mm). Dimensions & weights in parentheses are metric equivalent.

HOLE SIZING FOR NON-METALLIC CONDUIT / DUCT

NOMINAL SIZE	1/2"	3/4"	1"	1 1/4"	1 1/2"	2"	3"	4" (elec.)	4" (tele.)	5"	6"
CONDUIT O.D.	.840	1.050	1.315	1.660	1.900	2.375	3.500	4.500	4.350	5.563	6.625
HOLE SIZE	1"	1 1/4"	1 3/8"	1 3/4"	2"	2 1/2"	3 3/4"	4 3/4"	4 3/4"	5 3/4"	6 3/4"

Quazite recommends that holes be punched 1/8" to 1/4" larger than the actual outside diameter of the conduit duct. If more precise holes are required, contact your local QUAZITE® representative.

SPECIFICATIONS/DATA

Divided Boxes, Logos, Pad Options

Divided Boxes

Dividers are available for the following size enclosures:

24" x 36" x 18"	36" x 72" x 21"
24" x 36" x 30"	36" x 72" x 36"
24" x 36" x 42"	48" x 48" x 36"
30" x 48" x 18"	48" x 48" x 48"
30" x 48" x 36"	48" x 72" x 36"
30" x 60" x 21"	48" x 72" x 48"
30" x 60" x 36"	48" x 96" x 36"
36" x 36" x 36"	48" x 96" x 48"
36" x 60" x 36"	

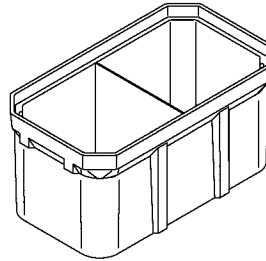

Dividers are typically located at the center of the box. Multiple dividers are also available. Additional dividers not listed may be available upon request. Contact your local QUAZITE® representative.

Logos

All covers are supplied without a logo unless specified. Most Commonly Used Logos may be ordered without an extra charge. Other available logos may be ordered with a set-up charge. New logos require a one time charge. (The PC0608 can accommodate only 13 letters and spaces.)

Most Commonly Used Cover Logos

17 Electric	7Z Telephone 20K Static Load
09 Blank	84 Power
46 Traffic Signal	22 Fire Alarm
41 Street Lighting	65 Illumination
12 Communications	26 High Voltage
10 CATV	38 Signal
79 Electric 20K Static Load	92 Telecommunications
50 Water	14 Controls
21 Fiber Optics	ZA Irrigation
44 Traffic	36 Security
29 Lighting	81 Danger High Voltage
43 Telephone	45 Traffic Control
24 Ground	

Pad Options

Struts - Galvanized Steel

Typical strut lengths are 3" and 5". Contact your local QUAZITE® representative for additional lengths.

Top-Grip Nuts - Zinc Plated

Available in 3/8" or 1/2" sizes.

Inserts - Zinc Alloy



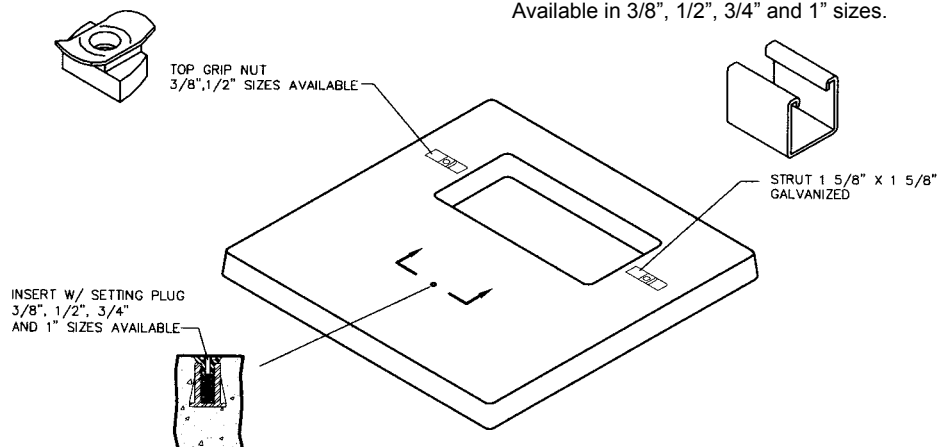





Available in 3/8", 1/2", 3/4" and 1" sizes.



SPECIFICATIONS/DATA

Color Options

The standard color for QUAZITE® products is concrete gray. Various color options allow for matching adjacent materials or special identification of enclosures. Some commonly requested colors include:

<u>Color Sample</u>	<u>Description</u>	<u>Part No. Code</u>
	Brick Red	R
	Forest Green	G
	Light Green	F
	Cement Gray	C
	Charcoal Gray	D
	Black	B
	Pecan	P
	International Orange	A
	Purple (non-potable water)	N



Color options seen above at the Tennessee State Aquarium in Chattanooga, Tennessee.

*Note: Printed colors do not exactly represent product colors.
Contact your local QUAZITE® representative for other special colors.*

When ordering, the color of the box and cover should be designated in the 6th digit of the part number. For example, a forest green PG1730BA18 box or cover would be ordered as PG173GBA18.

Electrical Equipment Pad Selection Guide

To Select the Pad You Need for Your Application:

- 1 Determine Type of Equipment**
- 2 Determine Pad Type**
- 3 Determine Pad Dimensions
- 4 Determine Performance Requirements
- 5 Determine Installation Requirements

Using The Selection Guide

Follow the steps outlined in this guide to select the appropriate pad for your application. For more information or for answers to any questions you might have, call your local QUAZITE® representative. Detailed product drawings can be found in this section and also can be viewed on our website:

www.quazite.com

1 Determine Type of Equipment

QUAZITE® offers a variety of pads and box pads that work with most transformers and switchgear manufactured today.

QUAZITE® pads are available for most Single-phase transformers rated 10 kVA - 167 kVA and Three-phase transformers rated up to 2,500 kVA. Larger sizes can be made to suit your application.

QUAZITE® switchgear box pads are designed to fit most manufacturers' switchgear rated 15 kV, 25 kV and 35 kV. Please see the Switchgear Cross Reference Guide on page 62 for more information.



Quazite offers QUAZITE® single-phase transformer pads that work with most transformers on the market today.

2 Determine Pad Type

QUAZITE® offers two types of pads to choose from: flat pads and box pads.

Flat pads and box pads offer different advantages. Flat pads are light weight and require only a small amount of digging to set. Flat pads can be installed on hillsides by using a hill holder. The optional SPLIT-PAD® design may be preferred for retrofit installations requiring the use of a flat pad. Box pads offer the advantage of providing room to train and coil extra cable underneath the equipment if needed.

Quazite's engineering staff will be happy to assist you in determining the proper pad for your application. Throat sizes and insert locations on both pads and box pads can be tailored to meet your requirements.



Lightweight QUAZITE® switchgear box pads (seen above) can be set in place with the backhoe used to dig the hole (precast concrete pads this size would require a crane to lift and install). The switchgear box pad also provides a large underground area with room to "train" cable into the switchgear.

Information shown in catalog is a partial listing. If pad or throat size desired is not listed, contact Quazite field sales office.

JANUARY 2011





Switchgear Box Pad Cross Reference Guide

To Select the Pad You Need for Your Application:

- 1 Determine Type of Equipment
- 2 Determine Pad Type**
- 3 Determine Pad Dimensions
- 4 Determine Performance Requirements
- 5 Determine Installation Requirements

Hubbell Power Systems (AB Chance)

Model	kV	Cabinet Size	Throat Size	Insert Location	Part No.
AIS-1	15-95	36 7/8 x 30	30 x 22	(2) 25 (Center)	PB44443022B32
AIS-1A	15-95	36 7/8 x 41	31 x 31	(2) 36 (Center)	PB44443131B32
AIS-6	15-95	64 1/2 x 75	57 x 67	49 1/2 x 70	PB74765767B36
AIS-9	15-95	64 1/2 x 75	57 x 67	49 1/2 x 70	PB74765767B36
AIS-10	15-95	70 1/2 x 75	57 x 67	55 1/2 x 70	PB74765767B36
AIS-11	15-95	70 1/2 x 75	57 x 67	55 1/2 x 70	PB74765767B36
AIS-12	15-95	64 1/2 x 84	57 x 67	49 1/2 x 70	PB74765767B36
AIS-13A	15-95	70 1/2 x 75	57 x 67	55 1/2 x 70	PB74765767B36
AIS-1	25-125	35 1/4 x 49 3/4	22 x 30	(2) 30 1/4 (Center)	PB40582230B24
AIS-1A	25-125	49 3/4 x 46 1/2	15 x 37	(2) 41 1/2 (Center)	PB52501537500
AIS-6	25-125	79 1/2 x 84	74 x 76	64 1/2 x 79	PB93937476B36
AIS-9	25-125	79 1/2 x 84	74 x 76	64 1/2 x 79	PB93937476B36
AIS-10	25-125	86 x 84	74 x 76	71 x 79	PB93937476B36
AIS-11	25-125	86 x 84	74 x 76	71 x 79	PB93937476B36
AIS-12	25-125	79 1/2 x 84	74 x 76	64 1/2 x 79	PB93937476B36
AIS-13A	25-125	86 x 84	74 x 76	71 x 79	PB93937476B36

S&C Electric

Model	kV	Cabinet Size	Throat Size	Insert Location	Part No.
PMH-6	14.4 Remote Supervisory	60 3/4 x 67	50 x 62	53 x 49	PB74765062B36
PMH-9	14.4 Remote Supervisory	60 3/4 x 67	50 x 62	53 x 49	PB74765062B36
PMH-10	14.4 Remote Supervisory	60 3/4 x 67	50 x 62	53 x 49	PB74765062B36
PMH-11	14.4 Remote Supervisory	60 3/4 x 67	50 x 62	53 x 49	PB74765062B36
PME-6	14.4 Manual & Remote	66 3/4 x 75	62 x 67	46 x 70	PB74766267B36
PME-9	14.4 Manual & Remote	66 3/4 x 75	62 x 67	46 x 70	PB74766267B36
PME-10	14.4 Manual & Remote	72 3/4 x 75	62 x 67	46 x 70	PB74766267B36
PME-11	14.4 Manual & Remote	72 3/4 x 75	62 x 67	46 x 70	PB74766267B36
PME-12	14.4 Manual	66 3/4 x 75	62 x 67	46 x 70	PB74766267B36
PMH-6	25 Remote Supervisory	76 3/4 x 82	66 x 72 1/2	69 x 64	PB93936672B36
PMH-9	25 Remote Supervisory	76 3/4 x 82	66 x 72 1/2	69 x 64	PB93936672B36
PMH-10	25 Remote Supervisory	76 3/4 x 82	66 x 72 1/2	69 x 64	PB93936672B36
PMH-11	25 Remote Supervisory	76 3/4 x 82	66 x 72 1/2	69 x 64	PB93936672B36
PME-6	25 Manual & Remote	81 3/4 x 84	77 x 72 1/2	52 x 78 1/2	PB93937277B36
PME-9	25 Manual & Remote	81 3/4 x 84	77 x 72 1/2	52 x 78 1/2	PB93937277B36
PME-10	25 Manual & Remote	88 1/4 x 84	77 x 72 1/2	58 1/2 x 78 1/2	PB93937277B36
PME-11	25 Manual & Remote	88 1/4 x 84	77 x 72 1/2	58 1/2 x 78 1/2	PB93937277B36
PME-12	25 Manual	81 3/4 x 84	77 x 72 1/2	52 x 78 1/2	PB93937277B36
320,321,330	15.5 (12,500) Manual	61 x 72	12 x 64	37 x 39, 55 1/2 x 57	PB74761264B36
320,321,330	15.5 (25,000) Manual	65 x 79	12 x 68	37 x 52, 59 1/2 x 64	PB93931268B36
320,321,330	29 (12,500) Manual	65 x 72	12 x 64	37 x 44 1/4, 59 1/2 x 57	PB74761264B36
320,321,330	29 (25,000) Manual	65 x 79	12 x 68	37 x 52, 59 1/2 x 64	PB93931268B36
320,321,330	38 (12,500) Manual	65 x 79	12 x 68	37 x 52, 59 1/2 x 64	PB93931268B36
320,321,330	38 (25,000) Manual	65 x 79	12 x 68	37 x 52, 59 1/2 x 64	PB93931268B36
413,422,431,440	15.5 (12,500) Manual	61 x 72	12 x 64	37 x 57, 55 1/2 x 51	PB74761264B36
413,422,431,440	15.5 (25,000) Manual	65 x 79	12 x 68	37 x 62, 59 1/2 x 57	PB93931268B36
413,422,431,440	29 (12,500) Manual	65 x 72	12 x 64	37 x 62, 59 1/2 x 57	PB74761264B36
413,422,431,440	29 (25,000) Manual	65 x 79	12 x 68	37 x 69 1/4, 59 1/2 x 64	PB93931268B36
413,422,431,440	38 (12,500) Manual	65 x 79	12 x 68	37 x 69 1/4, 59 1/2 x 64	PB93931268B36
413,422,431,440	38 (25,000) Manual	65 x 79	12 x 68	37 x 69 1/4, 59 1/2 x 64	PB93931268B36

Cooper Power (Kyle Type)

Contact your local QUAZITE® representative for details.

Federal Pacific

Model	kV	Cabinet Size	Throat Size	Insert Location	Part No.
PSE-SC-9	15	75 x 69 3/4	62 x 67	46 x 70	PB74766267B36
PSE-SC-11	15	75 x 72 3/4	62 x 67	46 x 70	PB74766267B36
PSE-SC-Deadfront	25	84 x 88 1/4	77 x 72 1/2	58 1/2 x 78 1/2	PB93937277B36
PSE-SC-Deadfront	25	81 3/4 x 84	77 x 72 1/2	52 x 78 1/2	PB93937277B36
PSI/II-5	25	74 1/2 x 43	43 x 60	66 1/2 x 35	PB74764360B36
PSI/II-61	15	67 x 72	62 x 67	46 x 70	PB74766267B36
PSI/II-9	15	58 1/2 x 67	50 x 62	53 x 49	PB74765062B36
PSI/II-9	25	74 1/2 x 82	66 x 72 1/2	69 x 64	PB93936672B36

G & W Electric

Information shown in catalog is a partial listing. If pad or throat size desired is not listed, contact Quazite field sales office.

JANUARY 2011

Contact your local QUAZITE® representative for details.



Electrical Equipment Pad Selection Guide

To Select the Pad You Need for Your Application:

- 1 Determine Type of Equipment
- 2 Determine Pad Type
- 3 Determine Pad Dimensions**
- 4 Determine Performance Requirements**
- 5 Determine Installation Requirements

3 Determine Pad Dimensions

To determine the proper pad dimensions for your application, calculate the size of the equipment and the amount of workspace desired and then specify the size and location of the throat. The electrical equipment footprint must match the pad/box pad dimensions and insert locations to ensure transformers and switchgear will properly mount to the pad or box pad. The pad/box pad also must have a throat opening that provides adequate space for cable and/or conduit to come through.

4 Determine Performance Requirements

QUAZITE® pads are constructed of strong polymer concrete and reinforced with a heavy-weave fiberglass. Unlike fiberglass or plastic pads, QUAZITE®'s strength assures that the pad will support the weight of the equipment mounted to it without bending or cracking. QUAZITE® pads are tested for structural integrity by applying a 1,000 lb. load to the surface distributed by a 5" x 7" steel plate. Each corner is tested separately by applying a 1,500 lb. load over the same plate positioned one inch from the edge. No damage occurs and deflection is less than 0.15".

QUAZITE® polymer concrete pads also resist UV rays, chemicals and water absorption. Plastic and fiberglass pads can become brittle and eventually crack when exposed to the weather. The durability that QUAZITE® provides means lower maintenance and life cycle costs.



Pad Performance

Performance Criteria	QUAZITE®			
	Precast Polymer Concrete Pads	Precast Concrete Pads	Poured-in-Place Concrete Pads	Thermoplastic / Fiberglass Pads
Stable under loading during high temperatures (won't flex or warp)	X	X	X	
Stable under loading during cold temperatures (won't crack)	X			
Not susceptible to damage caused by freeze/thaw cycles	X			X
Resistant to corrosion caused by weathering, road chemicals, and equipment lubricants	X			X
Provides long-term durability (fatigue or creep resistant)	X	X	X	
Withstands impacts and other damage caused by lawn equipment	X	X	X	



Information shown in catalog is a partial listing. If pad or throat size desired is not listed, contact Quazite field sales office.



Electrical Equipment Pad Selection Guide

- To Select the Pad You Need for Your Application:
- 1 Determine Type of Equipment
 - 2 Determine Pad Type
 - 3 Determine Pad Dimensions
 - 4 Determine Performance Requirements
 - 5 Determine Installation Requirements**

5 Determine Installation Requirements

Installing QUAZITE® pads is easy and cost effective because it requires no special equipment to set the pad. A backhoe is all that is necessary to lift the pad in place. QUAZITE® pads also save time during installation. Unlike poured-in-place pads that can take hours or days to form, pour, set, and remove the forms, QUAZITE® pads can be installed in a matter of minutes and installation of electrical equipment can begin immediately after the pad is set.

The optional SPLITT-PAD® design makes retrofit installations easy and eliminates the need to disconnect service during installation. Simply break away the old concrete or other material underneath the equipment cabinet and slip the SPLITT-PAD® underneath. Complete the installation by bolting the two-piece pad together at the throat. For more detailed instructions on how to install the SPLITT-PAD® and other QUAZITE® pads, see page 101.

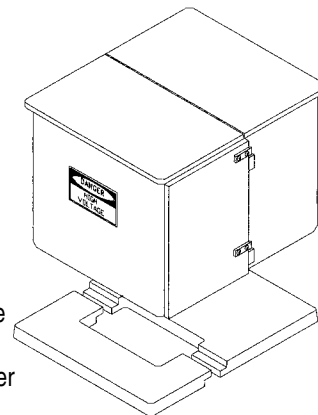

SPLITT-PAD®

Pad Installation

Installation Criteria	QUAZITE® Precast Polymer Concrete Pads	Precast Concrete Pads	Poured-in-Place Concrete Pads	Thermoplastic / Fiberglass Pads
Easily installed in areas with limited accessibility	X			X
Minimal planning and scheduling of crews required for installation	X			X
No special equipment (such as a boom truck or crane) needed for installation	X			X
Easily installed by no more than two crew members (lightweight)	X			X
Equipment and pad can be easily installed in the same day	X	X		X
Available as a two-piece pad so that service does not have to be disconnected when retrofitting	X			X
Flat surface allows equipment to fit flush with the pad	X			

Pad Numbering System

Weight	Style	Size	Throat Size	Item	Depth	Surface
P	L	4846	0817	A	3	T
L - Lightweight mix P - Standard mix	B - Box pad H - Electrical equipment pad J - Split electrical equipment pad K - Split telecommunications equipment pad L - Telecommunications equipment pad	48" x 46"	8" x 17"	A - 3/8-16 UNC inserts B - 1/2-13 UNC inserts C - 5/8-11 UNC inserts E - 5/8 thru hole F - Struts w/ 3/8" inserts G - Struts w/ 1/2" inserts H - Struts w/ 5/8" inserts	3" thick (Indicates surface thickness if flat pad; indicates depth if box pad.)	S - Smooth T - Skid resistant
Dimensions run parallel to each other.						

Information shown in catalog is a partial listing. If pad or throat size desired is not listed, contact Quazite field sales office.



SPECIFICATIONS/DATA

Box Pads

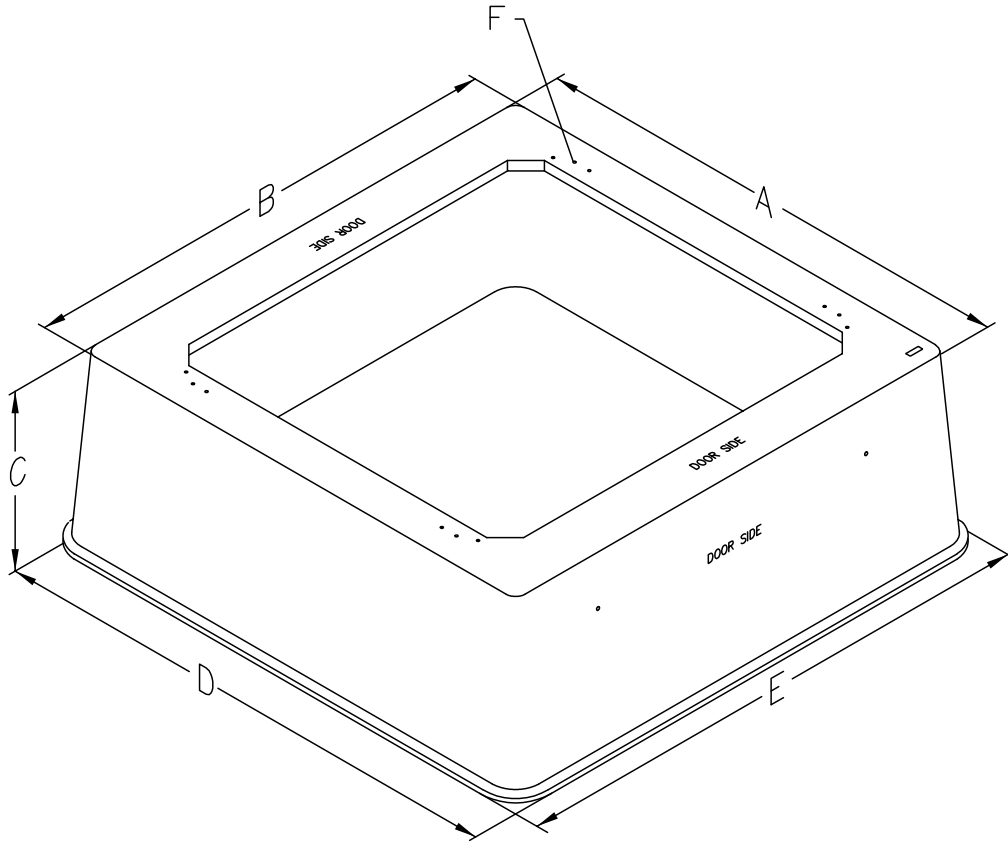

PART NO.	WT. (LBS.)	A	B	C	D	E	THROAT SIZE	F	INSERT/HOLE LOCATIONS
PB44442525B32	500# (226.8)	44" (1118)	44" (1118)	32" (813)	57" (1448)	57" (1448)	25 X 25	(8) 1/2-13 UNC	13 X 28
PB44442525E32	500# (226.8)	44" (1118)	44" (1118)	32" (813)	57" (1448)	57" (1448)	25 X 25	(8) 5/8 THRU	13 X 28
PB74761248B36	1277# (579.2)	74" (1880)	76" (1930)	36" (914.4)	87 1/4" (2216)	89 1/4" (2267)	12 X 48	(8) 1/2-13 UNC	57 X 55 1/2, 39 X 37
PB74761645036	1293# (586.5)	74" (1880)	76" (1930)	36" (914.4)	87 1/4" (2216)	89 1/4" (2267)	16 X 45	-	-
PB74764343B36	980# (444.5)	74" (1880)	76" (1930)	36" (914.4)	87 1/4" (2216)	89 1/4" (2267)	43 X 43	(6) 1/2-13 UNC	45 3/8 X 37, 40
PB74764360B36	980# (444.5)	74" (1880)	76" (1930)	36" (914.4)	87 1/4" (2216)	89 1/4" (2267)	43 X 60	(14) 1/2-13 UNC	57 5/8 X 2, 63 X 35, 63 X 39, 63
PB74765062B36	999# (453.1)	74" (1880)	76" (1930)	36" (914.4)	87 1/4" (2216)	89 1/4" (2267)	50 X 62	(8) 1/2-13 UNC	49 X 53, 61 1/2 X 53
PB74765656B36	880# (399.2)	74" (1880)	76" (1930)	36" (914.4)	87 1/4" (2216)	89 1/4" (2267)	56 X 56	(4) 1/2-13 UNC	50 1/2 X 61 1/2
PB74765767B36	786# (356.5)	74" (1880)	76" (1930)	36" (914.4)	87 1/4" (2216)	89 1/4" (2267)	57 X 67	(8) 1/2-13 UNC	70 X 49 1/2, 70
PB74766264B36	761# (345.2)	74" (1880)	76" (1930)	36" (914.4)	87 1/4" (2216)	89 1/4" (2267)	62 X 64	(4) 1/2-13 UNC	69 1/2 X 54
PB74766267502	841# (381.5)	74" (1880)	76" (1930)	36" (914.4)	87 1/4" (2216)	89 1/4" (2267)	62 X 67	(4) 1/2-13 UNC	46 X 70
PB74766267B36	841# (381.5)	74" (1880)	76" (1930)	36" (914.4)	87 1/4" (2216)	89 1/4" (2267)	62 X 67	(4) 1/2-13 UNC	46 X 70
PB74766268B36	748# (339.3)	74" (1880)	76" (1930)	36" (914.4)	87 1/4" (2216)	89 1/4" (2267)	62 X 68	(4) 1/2-13 UNC	71 1/2 X 46
PB93932442B36	1907# (865)	93" (2362)	93" (2362)	36" (914.4)	101" (2565)	101" (2565)	24 X 42	(4) 1/2-13 UNC	52 X 63
PB93936672B36	1363# (618.3)	93" (2362)	93" (2362)	36" (914.4)	101" (2565)	101" (2565)	66 X 72	(8) 1/2-13 UNC	64 X 69
PB93936875B36	1267# (574.7)	93" (2362)	93" (2362)	36" (914.4)	101" (2565)	101" (2565)	68 X 75	(4) 1/2-13 UNC	64 X 71
PB93937277B36	1238# (561.5)	93" (2362)	93" (2362)	36" (914.4)	101" (2565)	101" (2565)	72 X 77	(12) 1/2-13 UNC	65 X 76, 58 1/2 X 78 1/2, 52 X 78 1/2



Information shown in catalog is a partial listing. If pad or throat size desired is not listed, contact Quazite field sales office.

JANUARY 2011

SPECIFICATIONS/DATA

Box Pads

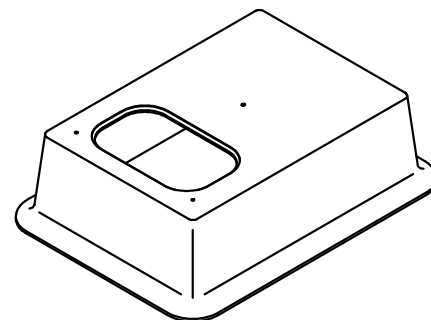
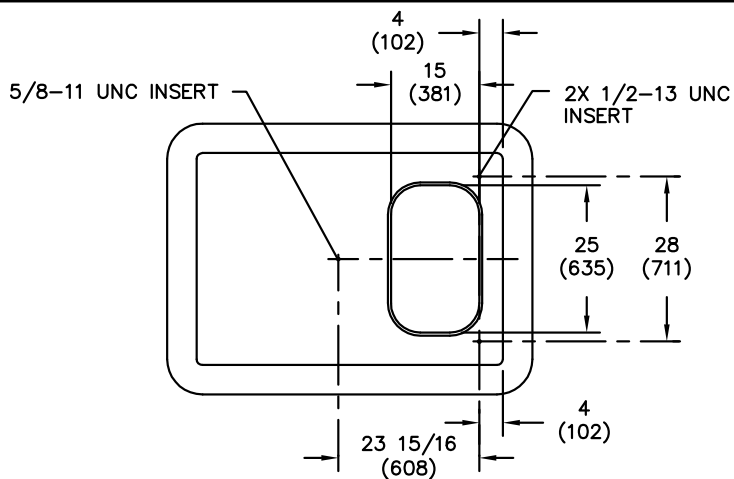

BOX PAD
PB52361525B18
(OLD PART NO. PB3652BA18)
377# (171)

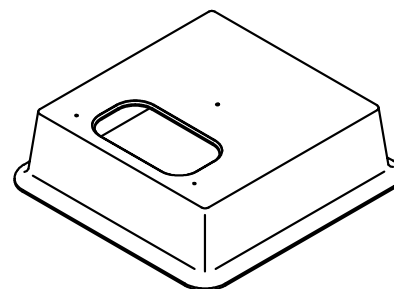
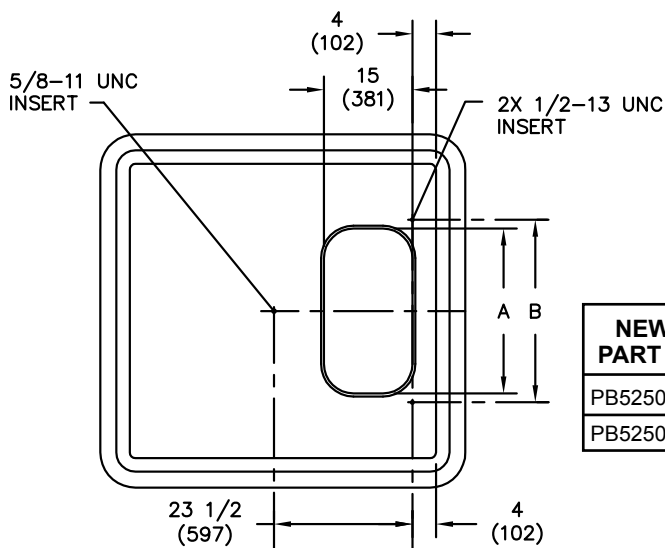
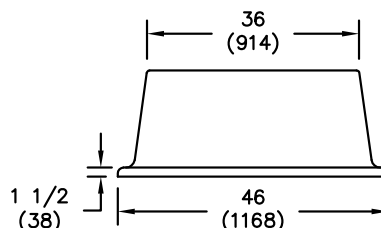

NEW PART NO.	OLD PART NO.	WEIGHT #	A	B
PB52501528B18	PB5052BA18	491 (223 kg)	28" (711 mm)	31" (787 mm)
PB52501537B18	PB5052B500	485 (220 kg)	37" (940 mm)	40" (1016 mm)

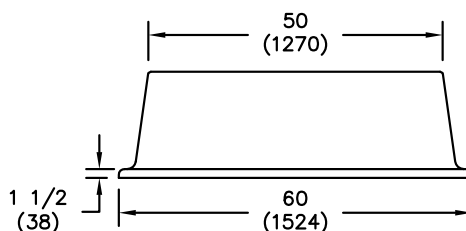
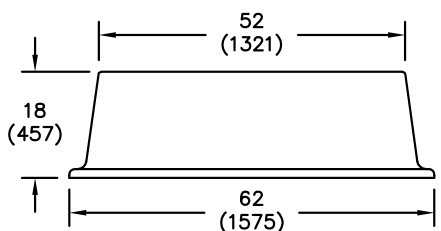

Dimensions in parentheses are metric equivalent.

Information shown in catalog is a partial listing. If pad or throat size desired is not listed, contact Quazite field sales office.

SPECIFICATIONS/DATA

Underground Distribution Switchgear Enclosure

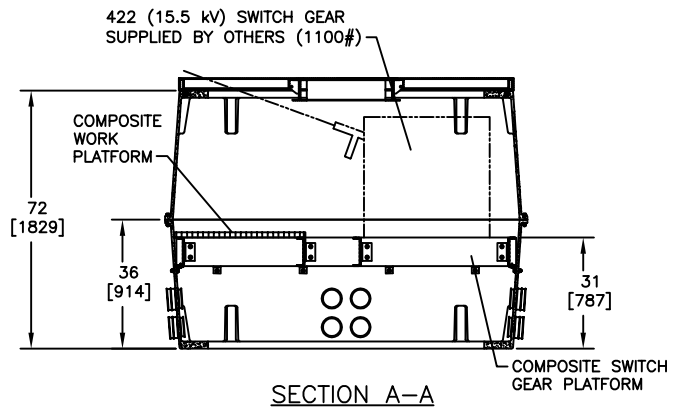
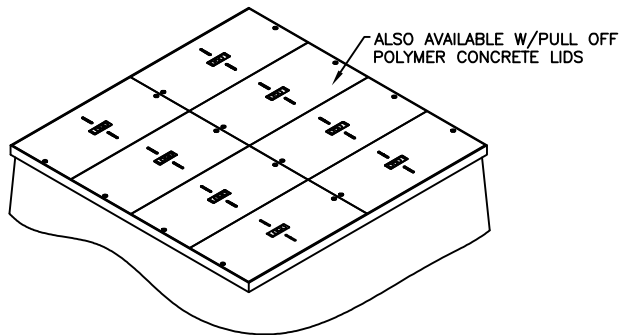
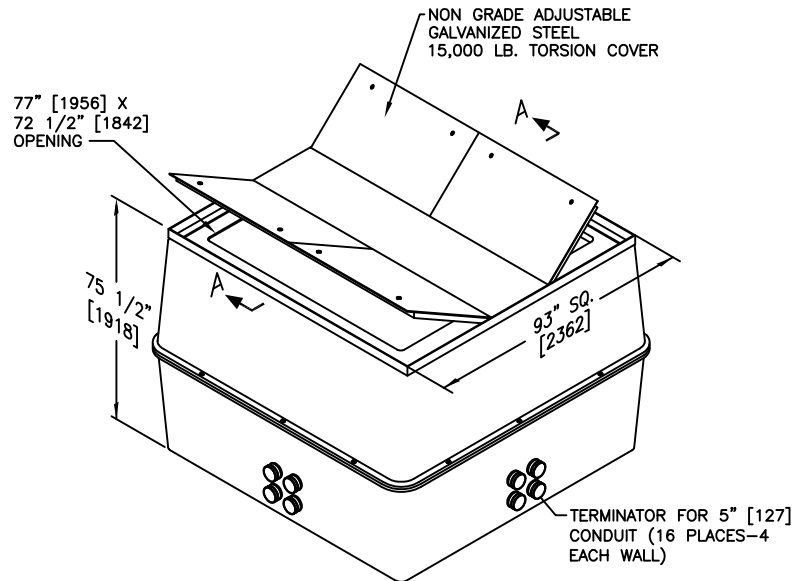

ASSEMBLY NUMBER	COVER OPTION	WEIGHT #
PB9393Z502	TORSION ASSIST	3,476 (1,577 kg)
PB9393Z505	POLYMER CONCRETE REMOVABLE	3,956 (1,794 kg)

If switchgear size or configuration is not shown, contact Quazite field sales office.

SPECIFICATIONS/DATA

Electric Equipment Pads

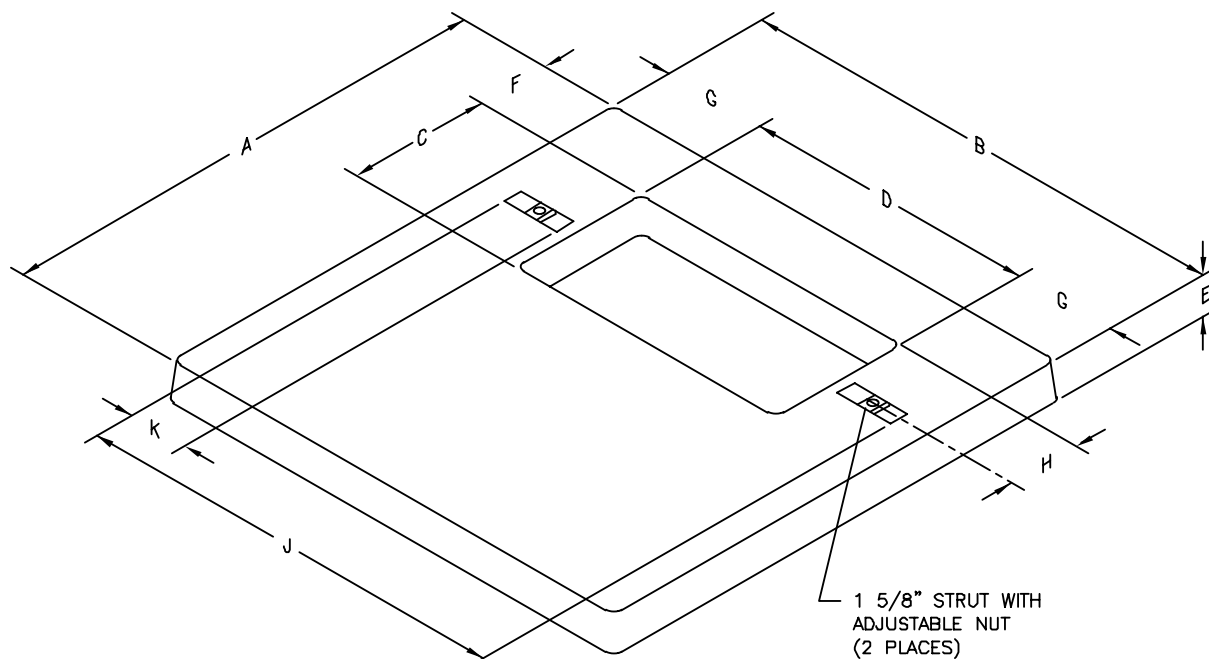

NEW PART NO.	OLD PART NO.	WEIGHT #	A	B	C	D	E	F	G	H	J	K
PH40401225F3S	PH4040BA	136	39 1/2"	39 1/2"	12"	25"	3 1/8"	5 3/4"	7 1/4"	6"	36 1/2"	5"
PH42421225F3S	PH4242BA	150	41 7/16"	41 7/16"	12 9/16"	25 9/16"	3 1/4"	5 7/16"	7 15/16"	6 5/16"	36 1/2"	5"
PH42421227G3S	PH4242B500	154	41 7/16"	41 7/16"	12 9/16"	27 9/16"	3 1/4"	5 7/16"	6 15/16"	6 5/16"	32"	2"
PH42421225G3T	PH4242B501*	150	41 7/16"	41 7/16"	12 9/16"	25 9/16"	3 1/4"	5 7/16"	7 15/16"	6 5/16"	30 9/16"	2 1/2"
PH42421225G3S	PH4242B503	150	41 7/16"	41 7/16"	12 9/16"	25 9/16"	3 1/4"	5 7/16"	7 15/16"	6 5/16"	39"	6"
PH42421227507	PH4242B507	154	41 7/16"	41 7/16"	12 9/16"	27 9/16"	3 1/4"	5 7/8"	6 15/16"	6 5/16"	32"	2"
PH42421225513	PH4242B513	150	41 7/16"	41 7/16"	12 9/16"	25 9/16"	3 1/4"	5 7/16"	7 15/16"	6 5/16"	36 1/2"	5"
PH42421424G3S	PH4242B515	150	41 7/16"	41 7/16"	14 9/16"	24 9/16"	3 1/4"	4 7/16"	8 7/16"	7 5/16"	33"	3"
PH42421225A3S	PH4242B518	150	41 7/16"	41 7/16"	12 9/16"	25 9/16"	3 1/4"	5 7/16"	7 15/16"	—	—	—
PH42421225512	PH4242D512	150	41 7/16"	41 7/16"	12 9/16"	25 9/16"	3 1/4"	5 7/16"	7 15/16"	6 5/16"	32 1/2"	3"
PH42421225520	PH4242DW	150	41 7/16"	41 7/16"	12 9/16"	25 9/16"	3 1/4"	5 7/16"	7 15/16"	6 5/16"	36 1/2"	5"
PH56441326G3S	PH4456B500	210	56"	44"	13 3/4"	26 3/4"	3 1/4"	6 1/4"	8 5/8"	6 13/16"	31 1/2"	2"
PH4842122603S	PH4842B500	165	48"	42"	12"	26"	3 1/4"	6"	8"	6"	32 1/4"	3"
PH48421227G4S	PH4842TB	170	48"	42"	12 3/4"	27 3/4"	4"	4 5/8"	7 1/8"	6 3/8"	38"	5"
PH48461826G3S	PH4846BA	161	48"	46"	18 9/16"	26 9/16"	3 1/4"	5 1/2"	9 11/16"	9 5/16"	37 1/2"	5"
PH54481826F4S	PH5448BA	220	54"	48"	18 3/4"	26 3/4"	4"	6 5/8"	10 5/8"	9 3/8"	37 3/4"	5"
PH66721842F4S	PH6672BA	454	66"	72"	18 3/4"	42 3/4"	4"	4 3/4"	14 5/8"	9 3/8"	53 3/4"	5"
PH75521728B4T	PH5275AD	290	75"	52"	17 11/16"	28 11/16"	4"	5 5/8"	11 5/8"	—	—	—
PH84960000500	PH9684AA	779	84"	96"	—	—	4"	—	—	—	—	—
PH84962269B4T	PH9684AD	887	84"	96"	22 3/4"	69 3/4"	4"	9"	13 1/8"	—	—	—

* Skid resistant surface

Additional sizes are available to meet your specific requirements.
Contact your local QUAZITE® representative for more information.

Information shown in catalog is a partial listing. If pad or throat size desired is not listed, contact Quazite field sales office.

JANUARY 2011



SPECIFICATIONS/DATA

Electric Equipment Pads

TELECOMMUNICATIONS
CABINET PADS

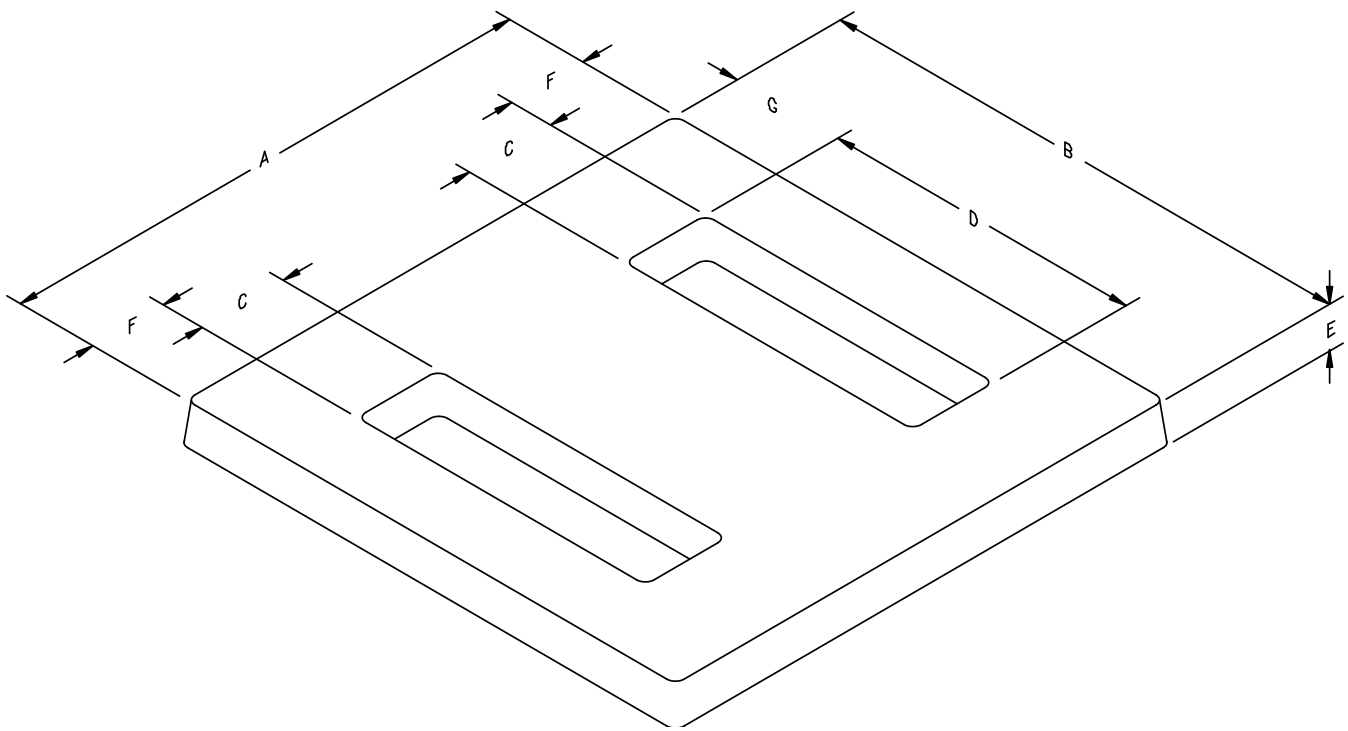

NEW PART NO.	OLD PART NO.	WEIGHT #	A	B	C	D	E	F	G	STRUTS/ INSERTS**
PH64640650F4S	PH6464AA	388	64"	64"	6 3/4"	50 3/4"	4"	11 1/4"	6 1/4"	(4) 6" struts
PH90482412F4S	PH9048AA	349	90"	48"	24 11/16"	12 3/4"	4"	8 1/8"	6"	(4) 5" struts
PH96802165B4T	PH8096AA*	494	96"	80"	21 3/4"	65 3/4"	4"	7"	7 1/8"	(4) 1/2-13 UNC

* Skid resistant surface

** See individual detail drawings for strut and insert locations.

Note: Individual detail drawings are available upon request.

Additional sizes are available to meet your specific requirements.
Contact your local QUAZITE® representative for more information.



Information shown in catalog is a partial listing. If pad or throat size desired is not listed, contact Quazite field sales office.

JANUARY 2011



Telecommunications Cabinet Pad Selection Guide

Using The Selection Guide

Follow the steps outlined in this guide to select the appropriate pad for your application. For more information or for answers to any questions you might have, call your local QUAZITE® representative. Detailed product drawings can be found in this section and also can be accessed from our website:

www.quazite.com

TELECOMMUNICATIONS
CABINET PADS

To Select the Pad You Need for Your Application:

- 1 Determine Cabinet to be Installed
- 2 Determine Pad Type
- 3 Determine Pad Dimensions
- 4 Determine Performance Requirements
- 5 Determine Installation Requirements

1 Determine Cabinet to be Installed

QUAZITE® pads are made to accommodate most of the telephone cabinets manufactured today. Please see the Telecommunications Cabinet Pad Cross Reference Guide on pages 71 - 73 to determine which standard QUAZITE® pad works best with the cabinet of your choice. If you do not see your cabinet listed, please contact your local QUAZITE® representative. Throat sizes and insert locations can be designed to meet your requirements.

2 Determine Pad Type

QUAZITE® offers two types of pads to choose from: flat pads and handhole cabinet pads. Determine the type of pad that will best suit your needs.

Flat pads and handhole cabinet pads offer different advantages. Flat pads are light weight and require only a small amount of site preparation. Handhole cabinet pads offer the advantage of providing room to coil extra cable underneath the equipment if needed. The multiple-piece cover serves as an access panel to the cables underneath



the cabinet and allows easy addition of more equipment and service connections to the cabinet.

Quazite's engineering staff is available to assist you in determining the proper pad for your application. Throat sizes and insert locations on both pads and handhole cabinet pads can be tailored to meet your requirements.



Rather than using a traditional flat pad for mounting telephone cabinets, some telecommunications companies are now opting to use a standard QUAZITE® handhole with a modified cover to fit the cabinet footprint. This design provides some distinct advantages over traditional pads. The space underneath the cover provides room to store extra cable. Also, the split in the two-piece cover lies at the edge of the cabinet and acts as an access panel to the cables underneath the cabinet.

Telecom companies with future plans to offer high-speed DSL, CATV or other telecommunications or broadband services in addition to telephone service should find the QUAZITE® handhole cabinet pad attractive. The access panel and additional space make it easy to add the necessary equipment and connections to existing telephone cabinets rather than installing new infrastructure to add services.

Information shown in catalog is a partial listing. If pad or throat size desired is not listed, contact Quazite field sales office.



Telecommunications Cabinet Pad Cross Reference Guide

3M

Cabinet	Bolt Pattern	New Pad No.	Old Pad No.
4065	6" x 12 1/4"	PL60420925500	PL6042MB
4082	6" x 12 1/4"	PL60420925500	PL6042MB
4084	30" x 6"	PL60420925500 PL60420925B3T PL60420720B3T PL57600926B4T PL78600926B4T	PL6042MB PL6042MC PL6042MM PL6057MA PL6078MA
4086	30" x 6"	PL60420925500 PL60420925B3T PL60420720B3T PL57600926B4T PL78600926B4T	PL6042MB PL6042MC PL6042MM PL6057MA PL6078MA
4220 D		PL60420720B3T	PL6042MM
4220 DD		PL60420720B3T	PL6042MM
4220 E	38 3/8" x 13"	PL60420720B3T	PL6042MM
4220 EE	38 3/8" x 13"	PL60420720B3T	PL6042MM
4220 F	59 3/8" x 13"	PL72640935B4T	PL6472AA
4220 G	59 3/8" x 13"	PL72640935B4T	PL6472AA
4220 K	59 3/8" x 13"	PL72640935B4T	PL6472AA
4220 KF	59 3/8" x 13"	PL72640935B4T	PL6472AA
4220 ER	38 3/8" x 13"	PL72640935B4T	PL6472AA
4220 FR	59 3/8" x 13"	PL72640935B4T	PL6472AA
4220 ER-A	38 3/8" x 13"	PL72640935B4T	PL6472AA
4220 FR-A	59 3/8" x 13"	PL72640935B4T	PL6472AA
4365	6" x 12 1/4"	PL60420925500	PL6042MB
4382	6" x 12 1/4"	PL60420925500	PL6042MB
4384	30" x 6"	PL60420925500 PL60420925B3T PL60420720B3T PL57600926B4T PL78600926B4T	PL6042MB PL6042MC PL6042MM PL6057MA PL6078MA
4386	30" x 6"	PL60420925500 PL60420925B3T PL60420720B3T PL57600926B4T PL78600926B4T	PL6042MB PL6042MC PL6042MM PL6057MA PL6078MA
4918	51 3/4" x 17", 46 3/4" x 21 5/16", CLX 44 13/16"	PL57600926B4T PL78600926B4T	PL6057MA PL6078MA
4927	51 3/4" x 17", 46 3/4" x 21 5/16", CLX 44 13/16"	PL57600926B4T PL78600926B4T	PL6057MA PL6078MA
4954	51 3/4" x 17", 46 3/4" x 21 5/16", CLX 44 13/16"	PL57600926B4T PL78600926B4T	PL6057MA PL6078MA
4981	51 3/4" x 17", 46 3/4" x 21 5/16", CLX 44 13/16"	PL57600926B4T PL78600926B4T	PL6057MA PL6078MA
4900P	51 3/4" x 17", 46 3/4" x 21 5/16", CLX 44 13/16"	PL57600926B4T PL78600926B4T	PL6057MA PL6078MA

Emerson (Marconi)

Cabinet	Bolt Pattern	New Pad No.	Old Pad No.
Cross Connect Cabinets			
ERLS / ECQF			
100 - 900 pr.	11" x 13 7/16"	PL42420808501	PL4242RA
UltraCab Series			
Single Access			
700 - 2700 pr.	37 7/8" x 8 1/2"	PL72600635500	PL6072SK
2700 Low Profile	37 7/8" x 8 1/2"	PL76840735500	PL8476RA
2800 - 4000 Long Base	37 7/8" x 8 1/2"	PL76840735500	PL8476RA

Information shown in catalog is a partial listing. If pad or throat size desired is not listed, contact Quazite field sales office.

To Select the Pad You Need for Your Application:

- 1 Determine Cabinet to be Installed
- 2 Determine Pad Type**
- 3 Determine Pad Dimensions
- 4 Determine Performance Requirements
- 5 Determine Installation Requirements

Emerson, cont. (Marconi)

Cabinet	Bolt Pattern	New Pad No.	Old Pad No.
Double Access			
1800 - 5400 pr.	37 7/8" x 8 1/2"	PL72600635500	PL6072SK
5400 Low Profile	37 7/8" x 8 1/2"	PL76840735500	PL8476RA
5500 - 8100 Long Base	37 7/8" x 8 1/2"	PL76840735500	PL8476RA
UNIVERSAL SERIES			
Single Access			
600 - 2700 pr.	37 7/8" x 8 1/2"	PL72600635500	PL6072SK
Double Access			
1200 - 5400 pr.	37 7/8" x 8 1/2"	PL72600635500	PL6072SK
UPCQF			
200 - 800 pr.	11" x 13 7/16"	PL42420808501	PL4242RA
RLS / CQF			
Sing. Acc. 600 - 2700 pr.	18 1/2" x 43"	PL72600635500	PL6072SK
Dble. Acc. 1200 - 5400 pr.	18 1/2" x 43"	PL72600635500	PL6072SK
DRLS / DCQF			
Single Access			
100 - 600 pr.	18 1/2" x 13"	PL72600635500	PL6072SK
700 - 2700 pr.	8 1/2" x 37 7/8"	PL72600635500	PL6072SK
2700 pr. - LP	8 1/2" x 37 7/8"	PL72600635500	PL6072SK
Double Access			
1800 - 5400 pr.	8 1/2" x 37 7/8"	PL72600635500	PL6072SK
5400 pr. - LP	8 1/2" x 37 7/8"	PL72600635500	PL6072SK
UPCBDS SERIES			
BDS100	4" x 12 1/4"	PL42420808501	PL4242RA
BDS200	11" x 12 1/4"	PL42420808501	PL4242RA
BDS300	11" x 12 1/4"	PL42420808501	PL4242RA
UPC SERIES			
BD7	11" x 12 1/4"	PL42420808501	PL4242RA
Multipurpose Cabinets			
1000	4" x 12 1/4"	PL42420808501	PL4242RA
1248	11" x 12 1/4"	PL42420808501	PL4242RA
1252S	11" x 12 1/4"	PL42420808501	PL4242RA
1278	11" x 12 1/4"	PL42420808501	PL4242RA
Lift Off Covers			
1000LOC	4" x 12 1/4"	PL42420808501	PL4242RA
1248LOC	11" x 12 1/4"	PL42420808501	PL4242RA
Cross Connect Housings			
600X	4" x 12 1/4"	PL42420808501	PL4242RA
1254	11" x 12 1/4"	PL42420808501	PL4242RA
1284	11" x 12 1/4"	PL42420808501	PL4242RA
1294	11" x 12 1/4"	PL42420808501	PL4242RA
Splice Housing Outdoor Terminal (SHOT)			
1850	15 3/16" x 15 1/4"	PL72600635500	PL6072SK
BD8000	15 5/16" x 15 1/4"	PL42420822B3T	PL4242SA
Repeater Housing			
BT1200V	11" x 12 1/4"	PL42420808501	PL4242RA
SC SERIES			
SC 6000D	32" x 13 1/2"	PL72600635500	PL6072SK
SC 8000D	43" x 16 1/2"	PL72600635500	PL6072SK
SC10000D	43" x 16 1/2"	PL72600635500	PL6072SK



Telecommunications Cabinet Pad Cross Reference Guide

TELECOMMUNICATIONS
CABINET PADS

Emerson, cont.

Cabinet	Bolt Pattern	New Pad No.	Old Pad No.
BROADBAND CLOSURES			
TV1600	4" x 12 1/4"	PL42420808501	PL4242RA
TV2400	11" x 12 1/4"	PL42420808501	PL4242RA
TV2500	11" x 12 1/4"	PL42420808501	PL4242RA
BROADBAND CABINETS - FIBER NODE (OPFOTV)			
OPFOTV 7	11" x 12 1/4"	PL42420808501	PL4242RA
OPFOTV 8	11" x 12 1/4"	PL42420808501	PL4242RA
OPFOTV 11	11" x 12 1/4"	PL42420808501	PL4242RA
FIBER OPTIC CABINETS			
OPFOBD 7	11" x 12 1/4"	PL42420808501	PL4242RA

Lucent Technologies

Cabinet	Bolt Pattern	New Pad No.	Old Pad No.
40 A	13" x 8 1/2"	PL42420808A3T	PL4242WA
40 B	21 5/8" x 8 1/2"	PL48460817A3T	PL4846YA
40 C	30 7/8" x 8 1/2"	PL48460827500 PL54480928501	PL4846WA PL5448WD
40 D	30 7/8" x 8 1/2"	PL48460827500 PL54480928501	PL4846WA PL5448WD
40 DD	30 7/8" x 16 1/8"	PL48460827500	PL4846WA
40 E	37 7/8" x 8 1/2"	PL54483408A4T PL54480928501 PL72600832A4T	PL5448WA PL5448WD PL6072EA
40 CE	37 7/8" x 8 1/2"	PL54483408A4T PL54480928501 PL72600832A4T	PL5448WA PL5448WD PL6072EA
40 EE	37 7/8" x 8 1/2"	PL54483408A4T PL54480928501 PL72600832A4T	PL5448WA PL5448WD PL6072EA
40 FE	37 7/8" x 8 1/2"	PL54483408A4T PL54480928501 PL72600832A4T	PL5448WA PL5448WD PL6072EA
40 F	36 1/2" x 13"	PL54483408A4T PL54480928501 PL72600832A4T	PL5448WA PL5448WD PL6072EA
40 H	30 7/8" x 8 1/2"	PL48460827500 PL54480928501	PL4846WA PL5448WD
42 EPI	37 7/8" x 8 1/2"	PL54483408A4T PL54480928501 PL72600832A4T	PL5448WA PL5448WD PL6072EA
841 A	13" x 8 1/2"	PL42420808A3T	PL4242WA
841 B	21 5/8" x 8 1/2"	PL48460817A3T	PL4846YA
841 C	30 7/8" x 8 1/2"	PL48460827500	PL4846WA

Hub (Tyco)

Cabinet	Bolt Pattern	New Pad No.	Old Pad No.
BTS-A			
Single Faced			
200 - 400 pr.	13" x 8 1/2"	PL42420808A3T	PL4242WA
BTS-C & D			
Single Faced			
600 - 1200 pr.	30 7/8" x 8 1/2"	PL48460827500	PL4846WA
Double Faced			
1200 - 2400 pr.	30 7/8" x 8 1/2"	PL48460827500	PL4846WA

To Select the Pad You Need for Your Application:

- 1 Determine Cabinet to be Installed
- 2 Determine Pad Type**
- 3 Determine Pad Dimensions
- 4 Determine Performance Requirements
- 5 Determine Installation Requirements

Hub, cont. (Tyco)

Cabinet	Bolt Pattern	New Pad No.	Old Pad No.
BTS-E			
Single Faced			
1500 - 3000 pr.	37 7/8" x 8 1/2"	PL54483408A4T	PL5448WA
Double Faced			
2700 - 3600 pr.	37 7/8" x 8 1/2"	PL72600832A4T	PL6072EA
BTS-LP			
Single Faced			
200 - 400 pr.	8 1/2" x 13"	PL54481109B4T	PL5448HA
600 pr.	37 7/8" x 8 1/2"	PL48460827500	PL4846WA
900 - 1800 pr.	37 7/8" x 8 1/2"	PL48460735B3T PL72600735B4T	PL4846HA PL6072HA
2100 - 3000 pr.	37 7/8" x 8 1/2"	PL76840735B4T	PL8476HA
3300 - 3600 pr.	37 7/8" x 8 1/2"	PL96840435A4T	PL9684HA
Double Faced			
1200 - 1600 pr.	37 7/8" x 8 1/2"	PL54480420A4T	PL5448HA
2700 - 3600 pr.	37 7/8" x 8 1/2"	PL72600735B4T	PL6072HA
5400 - 9000 pr.	37 7/8" x 8 1/2"	PL76840735B4T	PL8476HA
BNS			
Single Faced			
200 - 1200 pr.	37 7/8" x 8 1/2"	PL54480420A4T	PL5448HA
1500 - 2700 pr.	37 7/8" x 8 1/2"	PL64860435A4T	PL6486HA
Double Faced			
1600 - 2400 pr.	37 7/8" x 8 1/2"	PL54480420A4T	PL5448HA
2100 - 5400 pr.	37 7/8" x 8 1/2"	PL96840435A4T	PL9684HA
42 EPI	37 7/8" x 8 1/2"	PL54483408A4T PL72600832A4T	PL5448WA PL6072EA

Erpel (EDC)

Cabinet	Bolt Pattern	New Pad No.	Old Pad No.
DOUBLE DOOR			
DBL363213	27" x 8"	PL42420822B3T	PL4242SA
DBL483615	31" x 10"	PL48460827A3T	PL4846WX
DBL604415	39" x 10"	PL48460735B3T	PL4846HA
DBL604830	43" x 25"	PL54482308B4T	PL5448CA
DBL666015	55" x 10"	PL72601032A4T	PL6072AA
DBL724818	43" x 13"	PL54483408A4T	PL5448WA
DBL724824	43" x 19"	PL54483408A4T	PL5448WA
DBL727215	67" x 10"	PL76840735B4T	PL8476HA
DBL727224	67" x 19"	PL76840735B4T	PL8476HA
DBL727236	67" x 31"	PL76840735B4T	PL8476HA
DBL917224	67" x 19"	PL76840735B4T	PL8476HA

Cabinet	Bolt Pattern	New Pad No.	Old Pad No.
FLUSH DOOR			
FD503119	39" x 13 4/5"	PL42420822B3T	PL4242SA
FD553826	34 1/2" x 22 1/2"	PL48460827A3T	PL4846WX
FD554426	40 1/2" x 22 1/2"	PL48460827A3T	PL4846WX
FD773826	34 1/2" x 22 1/2"	PL48460827A3T	PL4846WX
FD774426	40 1/2" x 22 1/2"	PL48460827A3T	PL4846WX
FD727224	68 1/2" x 20 1/2"	PL76840735B4T	PL8476HA

If your cabinet is not listed here, please contact your local QUAZITE® representative for additional sizes and insert configurations.
Information shown in catalog is a partial listing. If pad or throat size desired is not listed, contact Quazite field sales office.

Telecommunications Cabinet Pad Cross Reference Guide

Erpel (EDC), cont.

Cabinet	Bolt Pattern	New Pad No.	Old Pad No.
FRONT AND REAR DOOR			
FDR363624	32 1/2" x 20 1/2"	PL42420822B3T	PL4242SA
FDR443624	32 1/2" x 20 1/2"	PL42420822B3T	PL4242SA
FDR773826	34 1/2" x 22 1/2"	PL48460827A3T	PL4846WX
FDR774426	40 1/2" x 22 1/2"	PL48460827A3T	PL4846WX

LARGE SINGLE DOOR

LSD301815	CL x 12 1/2"	PL42420808A3T	PL4242WA
LSD362015	CL x 12 1/2"	PL42420808A3T	PL4242WA
LSD412516	CL x 12 1/2"	PL42420808A3T	PL4242WA
LSD512516	CL x 12 1/2"	PL42420808A3T	PL4242WA
LSD503017	26 1/2" x 13 1/2"	PL42420822B3T	PL4242SA
LSD503617	32 1/2" x 13 1/2"	PL42420822B3T	PL4242SA
LSD583017	26 1/2" x 13 1/2"	PL42420822B3T	PL4242SA
LSD763017	26 1/2" x 13 1/2"	PL42420822B3T	PL4242SA
LSD723617	32 1/2" x 13 1/2"	PL42420822B3T	PL4242SA
LSD363624	32 1/2" x 16 1/2"	PL42420822B3T	PL4242SA
LSD443624	32 1/2" x 16 1/2"	PL42420822B3T	PL4242SA
LSD553826	34 1/2" x 18 1/2"	PL42420822B3T	PL4242SA
LSD554426	40 1/2" x 18 1/2"	PL42420822B3T	PL4242SA
LSD773826	34 1/2" x 18 1/2"	PL42420822B3T	PL4242SA
LSD774426	40 1/2" x 18 1/2"	PL42420822B3T	PL4242SA

QUAD DOOR

LQD484836	43" x 31"	PL48460735B3T	PL4846HA
LQD587430	69", CL x 25"	PL76840735B4T	PL8476HA
LQD605036	45" x 31"	PL54482308B4T	PL5448CA
LQD605636	51" x 31"	PL72601032A4T	PL6072AA
LQD727224	67", CL x 19"	PL76840735B4T	PL8476HA
LQD774826	43" x 21"	PL48460735B3T	PL4846HA

RACK MOUNT

ERM392421	15" x 15"	PL42420808A3T	PL4242WA
ERM462421	15" x 15"	PL42420808A3T	PL4242WA
ERM463027	21" x 21"	PL42420808A3T	PL4242WA
ERM553027	21" x 21"	PL42420808A3T	PL4242WA
ERM672430	15" x 25"	PL42420808A3T	PL4242WA
ERM672438	15" x 33"	PL42420808A3T	PL4242WA

TWO DOOR

ETD666016	46 1/4" x 12"	PL78600926B4T	PL6078MA
ETD727216	58 1/4" x 12"	PL78600926B4T	PL6078MA

COMMUNICATIONS ENCLOSURES

CE-1000	24 1/2" x 27 1/10", 39" x 35 2/5"	PL78600926B4T	PL6078MA
CE-2000	53" x 27 1/10", 67 1/2" x 35 2/5"	PL76840735B4T	PL8476HA

Multilink

Cabinet	Bolt Pattern	New Pad No.	Old Pad No.
FNC 2000	11 3/4" x 23"	PL42420822501	PL4242ML
FNC 3000	23 3/16" x 29 1/8"	PL54482308B4T	PL5448CA
FNC 3000 - 5016	12 1/8" x 24 3/16"	PL42420822501	PL4242ML

To Select the Pad You Need for Your Application:

- 1 Determine Cabinet to be Installed
- 2 Determine Pad Type**
- 3 Determine Pad Dimensions
- 4 Determine Performance Requirements
- 5 Determine Installation Requirements

Flextronics Enclosure Systems (Chatham Technologies)

Cabinet	Bolt Pattern	New Pad No.	Old Pad No.
RACK MOUNT			
RM392420	15" x 15"	PL42420808A3T	PL4242WA
RM462420	15" x 15"	PL42420808A3T	PL4242WA
RM672430	21" x 21"	PL42420808A3T	PL4242WA
RM672438	21" x 21"	PL42420808A3T	PL4242WA
RM463026	15" x 25"	PL42420808A3T	PL4242WA
RM553026	15" x 33"	PL42420808A3T	PL4242WA
UCN			
UCN 100	20" x 25"	PL78600926B4T	PL6078MA
UCN 200	46" x 25"	PL76840735B4T	PL8476HA

TELECOMMUNICATIONS
CABINET PADS

If your cabinet is not listed here, please contact your local QUAZITE® representative for additional sizes and insert configurations.

Information shown in catalog is a partial listing. If pad or throat size desired is not listed, contact Quazite field sales office.

JANUARY 2011





Telecommunications Cabinet Pad Selection Guide

To Select the Pad You Need for Your Application:

- 1 Determine Type of Cabinet to be Installed
- 2 Determine Pad Type
- 3 Determine Pad Dimensions**
- 4 Determine Performance Requirements**
- 5 Determine Installation Requirements

TELECOMMUNICATIONS CABINET PADS

3 Determine Pad Dimensions

To ensure telephone cabinets will properly mount to the pad, the cabinet footprint must match the pad dimensions and insert locations. The pad also must have a throat opening that provides adequate space for cable and/or conduit to come through.

How much work space you need around the cabinet also will affect the dimensions of the pad. Determine how far the pad should extend beyond the cabinet to allow for adequate work space and cabinet entry and select the pad accordingly.

The Telecommunications Cabinet Pad Cross Reference Guide in this section lists the appropriate QUAZITE® pads for the most common cabinets manufactured today. If you need assistance determining which pad has the appropriate throat size and insert locations to work with your cabinet, please contact your local QUAZITE® representative.

4 Determine Performance Requirements

QUAZITE® pads are constructed of strong polymer concrete and reinforced with a heavy-weave fiberglass mat. Unlike fiberglass or plastic pads, QUAZITE®'s strength assures that the pad will support the weight of the equipment mounted to it without bending or cracking. QUAZITE® pads have been tested for structural integrity by applying a 1,000 lb. load to the surface distributed by a 5" x 7" steel plate. Each corner was tested separately by applying a 1,500 lb. load over the same plate positioned one inch from the edge. No damage occurred and deflection was less than 0.15".

QUAZITE® polymer concrete pads also resist UV rays, chemicals, and water absorption. Plastic and fiberglass pads can become brittle and eventually crack when exposed to the weather. The durability that QUAZITE® provides means lower maintenance and life cycle costs.

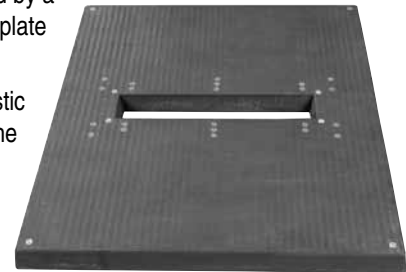

Pad Performance

Performance Criteria	QUAZITE®			
	Precast Polymer Concrete Pads	Precast Concrete Pads	Poured-in-Place Concrete Pads	Thermoplastic / Fiberglass Pads
Stable under loading during high temperatures (won't flex or warp)	X	X	X	
Stable under loading during cold temperatures (won't crack)	X			X
Not susceptible to damage caused by freeze/thaw cycles	X			X
Resistant to corrosion caused by weathering, road chemicals, and equipment lubricants	X			X
Provides long-term durability (fatigue or creep resistant)	X	X	X	
Withstands impacts and other damage caused by lawn equipment	X	X	X	

Information shown in catalog is a partial listing. If pad or throat size desired is not listed, contact Quazite field sales office.

JANUARY 2011



Telecommunications Cabinet Pad Selection Guide

- To Select the Pad You Need for Your Application:
- 1 Determine Type of Cabinet to be Installed
 - 2 Determine Pad Type
 - 3 Determine Pad Dimensions
 - 4 Determine Performance Requirements
 - 5 Determine Installation Requirements**

5 Determine Installation Requirements

Installing QUAZITE® pads is easy and cost effective because it requires no special equipment to set the pad. A backhoe is all that is necessary to lift the pad into place. QUAZITE® pads also save time during installation. Unlike poured-in-place pads that can take hours or days to form, pour, set and remove the forms, QUAZITE® pads can be installed in a matter of minutes and installation of electrical equipment can begin immediately after the pad is set.

The optional SPLITT-PAD® design makes retrofit installations easy and eliminates the need to disconnect service during installation. Simply break away the old concrete or other material underneath the equipment cabinet and slip the SPLITT-PAD® underneath. Complete the installation by bolting the two-piece pad together at the throat. For more detailed instructions on how to install the SPLITT-PAD® and other QUAZITE® pads, see page 101.

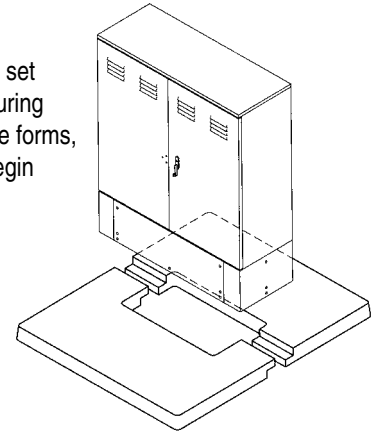

SPLITT-PAD®

TELECOMMUNICATIONS CABINET PADS

Pad Installation

Installation Criteria	QUAZITE®			
	Precast Polymer Concrete Pads	Precast Concrete Pads	Poured-in-Place Concrete Pads	Thermoplastic / Fiberglass Pads
Easily installed in areas with limited accessibility	X			X
Minimal planning and scheduling of crews required for installation	X			X
No special equipment (such as a boom truck or crane) needed for installation	X			X
Easily installed by no more than two crew members (light weight)	X			X
Equipment and pad can be easily installed in the same day	X	X		X
Available as a two-piece pad so that service does not have to be disconnected when retrofitting	X			X
Flat surface allows cabinet to fit flush with the pad	X			

Pad Numbering System

Weight	Style	Size	Throat Size	Item	Depth	Surface
P L - Lightweight mix P - Standard mix	L B - Box pad H - Electrical equipment pad J - Split electrical equipment pad K - Split telecommunications equipment pad L - Telecommunications equipment pad	4846 48" x 46"	0817 8" x 17"	A A - 3/8-16 UNC inserts B - 1/2-13 UNC inserts C - 5/8-11 UNC inserts E - 5/8 thru hole F - Struts w/ 3/8" inserts G - Struts w/ 1/2" inserts H - Struts w/ 5/8" inserts	3 3" thick (Indicates surface thickness if flat pad; indicates depth if box pad.)	T S - Smooth T - Skid resistant

Dimensions run parallel to each other.

Information shown in catalog is a partial listing. If pad or throat size desired is not listed, contact Quazite field sales office.



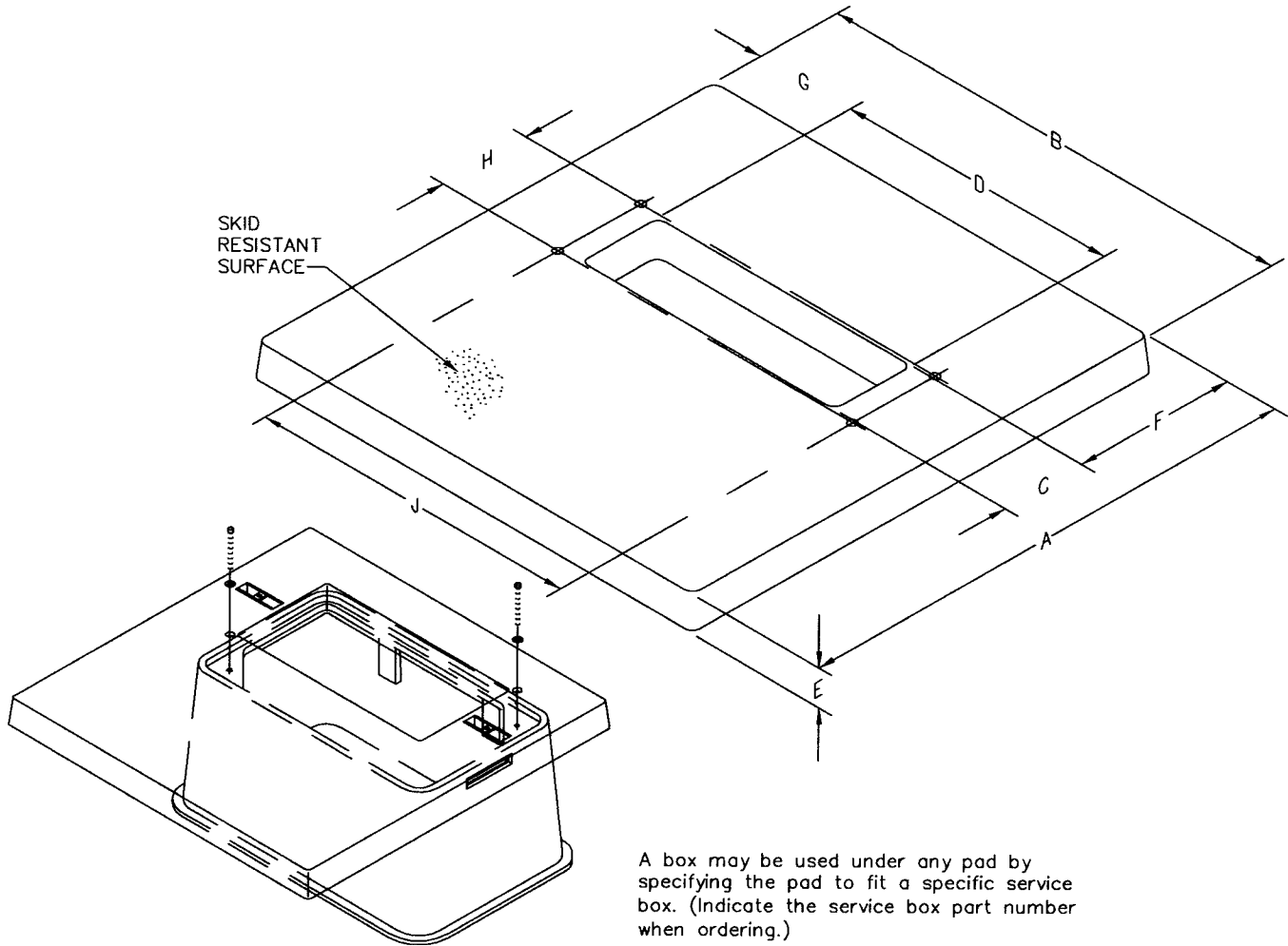

Information shown in catalog is a partial listing. If pad or throat size desired is not listed, contact Quazite field sales office.

JANUARY 2011

SPECIFICATIONS/DATA

Telecommunications Cabinet Pads

**TELECOMMUNICATIONS
CABINET PADS**

Refer to Telecommunications Cabinet Pad Cross Reference Guide on pages 71- 73.

NEW PART NO.	OLD PART NO.	WEIGHT #	A	B	C	D	E	F	G	H	J	INSERTS
PL42420822500	PL4242ML	136	41 7/16"	41 7/16"	8 9/16"	22 1/16"	3 1/4"	16 7/16"	9 11/16"	11 3/4"	23"	(12) 1/2-13 UNC
										18 5/8"	27 13/16"	
										29 1/8"	23 3/16"	
PL48460817A3T	PL4846YA	139	47 1/2"	45 1/2"	8 9/16"	17 13/16"	3 1/4"	14 11/16"	13 13/16"	8 1/2"	21 5/8"	(4) 3/8-16 UNC
PL48460827500	PL4846WA	172	47"	45"	8 9/16"	27 1/16"	3 1/4"	14 1/2"	10"	8 1/2"	30 7/8"	(6) 3/8-16 UNC
										See sales drawing		
PL54483408A4T	PL5448WA	213	47 1/4"	53 1/4"	8 3/4"	34 1/8"	4"	14 3/8"	9 9/16"	C-LINE	13"	(14) 3/8-16 UNC
										36 1/2"	13"	
										37 7/8"	8 1/2"	
										37 7/8"	17 3/8"	
PL60420720B3T	PL6042MM	240	60"	42"	7 9/16"	20 9/16"	3 1/4"	26 3/16"	10 3/4"	10"	16"	(12) 1/2-13 UNC
										13"	24"	
										13"	38 1/2"	
PL60420925500	PL6042MB	192	57 1/2"	39 1/2"	9 1/8"	25 5/8"	3 5/16"	24 3/16"	6 15/16"	6"	30"	(16) 3/8-16 UNC
										10"	30 3/4"	
										12 1/4"	6"	
										See sales drawing		
PL60420925B3T	PL6042MC	189	57 7/16"	39 7/16"	9 5/16"	25 15/16"	3 1/4"	24 1/16"	6 3/4"	6"	30"	(8) 1/2-13 UNC
										10"	30 3/4"	
PL57600926B4T	PL6057MA	362	57 1/16"	60 1/16"	9 11/16"	26 3/16"	4"	2 3/16"	16 15/16"	30"	6"	(4) 1/2-13 UNC
										30 3/4"	10"	
										46 3/4"	21 5/16"	(2) 1/2-13 UNC
										51 3/4"	17"	
										52"	10"	(4) 1/2-13 UNC
C-LINE	23 13/16"	(1) 1/2-13 UNC										
PL72640935B4T	PL6472AA	473	72"	64"	9 11/16"	35 11/16"	4"	31 1/8"	14 1/8"	13"	59 3/8"	(4) 1/2-13 UNC
										21 1/2"	41 1/2"	
										25 1/4"	34 1/2"	
										30 3/4"	46 3/4"	(2) 1/2-13 UNC
										35 5/16"	51 3/4"	
										19 11/16"	C-LINE	(1) 1/2-13 UNC
PL76840735B4T	PL8476HA	616	76"	84"	7 3/4"	35 7/8"	4"	34 1/4"	24 1/16"	33 3/4"	10"	(16) 1/2-13 UNC
										37 7/8"	6"	
										37 7/8"	11"	
										59 3/8"	13"	

Note: Individual detail drawings are available upon request.
 Additional sizes are available to meet your specific requirements.
 Contact your local QUAZITE® representative for more information.



Information shown in catalog is a partial listing. If pad or throat size desired is not listed, contact Quazite field sales office.

SPECIFICATIONS/DATA

Cell Site Enclosure

TELECOMMUNICATIONS
CABINET PADS

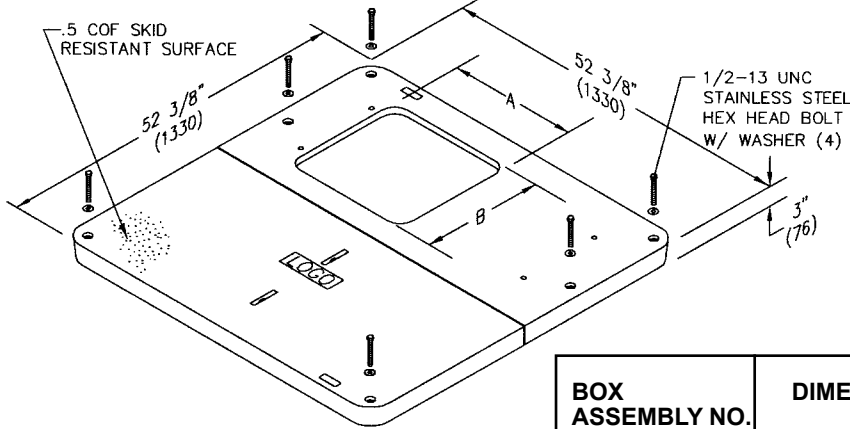

BOX ASSEMBLY NO.	DIMENSION A	DIMENSION B	Hub Cabinet
PG4848Z511	19" (483 mm)	18 1/8" (460 mm)	CSC
PG4848Z505	10" (254 mm)	18 1/4" (464 mm)	CFL

Dimensions & weights in parentheses are metric equivalent.

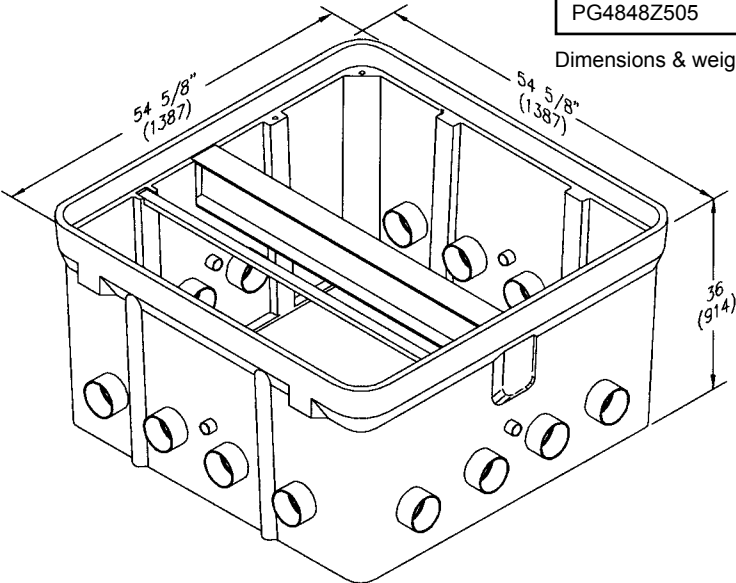

QUAZITE® cell site enclosures allow cellular providers easy access to their cable lines and provide plenty of room for the addition of new lines. Sixteen 4" terminators enable providers to easily add new feeder cables to existing sites. The terminators also reduce the risk of disturbing existing service when adding new cables because installers can clearly see where other cables are entering the box.

QUAZITE® cell site enclosures also make equipment changes and upgrades easy and cost effective. Poured-in-place pads must be completely replaced if changes and upgrades became necessary, but QUAZITE® cell site enclosures feature replaceable covers and an open area inside the enclosure. As a result, new cable lines can easily be added without replacing the pad. Also, providers only need to replace the covers if cabinets with new bolt patterns are installed.

Information shown in catalog is a partial listing. If pad or throat size desired is not listed, contact Quazite field sales office.



SPECIFICATIONS/DATA

Cabinet Enclosures

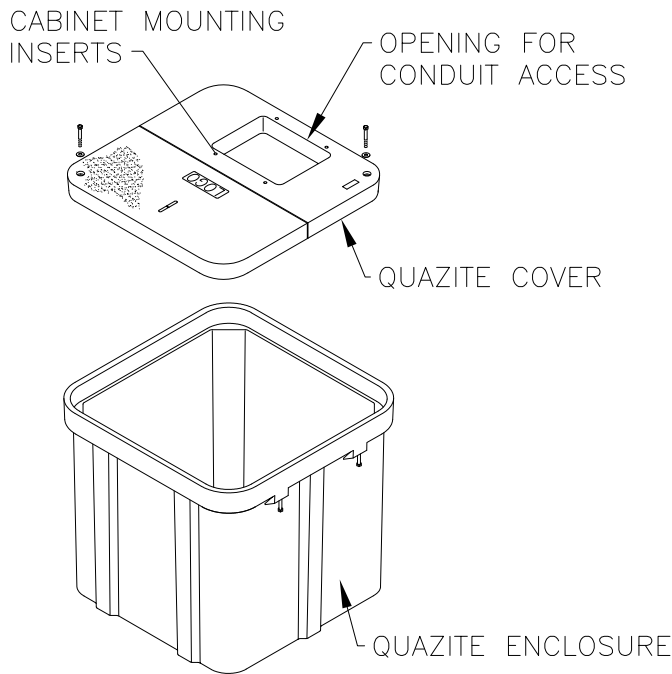

TELECOMMUNICATIONS
CABINET PADS

Cabinet Manufacturer & Model Number	Assembly Size
ACE 214	48 X 48 X 36
ACE 92, 100, & 200	36 X 60 X 36
ADC 576	48 X 48 X 36
ADC FAT	24 X 36 X 42
ADC Gen 2	36 X 60 X 36 & 48 X 48 X 36
ADC Gen 3 & 3E FDH 144, 216, 288, & 432	36 X 36 X 36 & 48 X 48 X 36
ADC Medium 216/432	36 X 36 X 36
ADC Small 144	36 X 36 X 36
ADC Splitter FDH1G-144/216	36 X 60 X 36
AFL FDH 100 (FD000094 MTG. SKIRT)	30 X 48 X 24, 36 X 60 X 24, 36 X 60 X 36, & 48 X 48 X 36
APA 576/816	36 X 72 X 36
Charles BD03	24 X 24 X 24, 24 X 36 X 30, 30 X 48 X 36, 36 X 60 X 36, & 48 X 72 X 48
Charles BD04	24 X 24 X 24, 24 X 36 X 30, 30 X 48 X 36, 36 X 60 X 36, & 48 X 72 X 48
Charles BD05	24 X 24 X 24, 24 X 36 X 30, 30 X 48 X 36, 36 X 60 X 36, & 48 X 72 X 48
Charles BD07	24 X 24 X 24, 24 X 36 X 30, 30 X 48 X 36, 36 X 60 X 36, & 48 X 72 X 48
Corning 144/216	36 X 60 X 36
Corning 216 or LCA 288	36 X 36 X 36
Corning Gen 3	36 X 72 X 36
Corning Gen 3 & 3E FDH 144, 216, 288, & 432	36 X 36 X 36 & 48 X 48 X 36
Corning LCA-432	36 X 60 X 36
Corning Nex Gen LCA-432	36 X 36 X 36
Emerson/Marconi UPCBD7	30 X 48 X 36, & 48 X 72 X 48
Emerson Sole	30 X 48 X 36
Emerson Span	48 X 48 X 48
Hub CSC	48 X 72 X 48
OFS Orbital 288 FTTX	36 X 36 X 36

Information shown in catalog is a partial listing. If cabinet model number, throat size, or mounting insert locations desired are not listed, contact Quazite field sales office.



Traffic Signal Cabinet Base Selection Guide

To Select the Traffic Signal Cabinet Base You Need for Your Application:

- 1 Determine Type of Cabinet**
- 2 Determine Work Pad Requirements**
- 3 Determine Performance Requirements
- 4 Determine Installation Requirements

Using This Selection Guide

Follow the steps outlined in this guide to select the appropriate traffic signal cabinet base for your application. For more information or for answers to any questions you might have, call your local QUAZITE® representative. Detailed product drawings are included in this section and also can be accessed from our website:

www.quazite.com

TRANSPORTATION INDUSTRY PRODUCTS

1 Determine Type of Cabinet

QUAZITE® offers a variety of traffic signal cabinet bases that work with every NEMA and 170E cabinet manufactured today.

The footprint of the cabinet will determine which base to install. Please see the Traffic Signal Cabinet Base Cross Reference Guide on pages 81 - 82 to choose the proper base for your application. If your cabinet is not listed, please feel free to contact your local QUAZITE® representative. Throat sizes and insert locations can be tailored to meet your requirements.



2 Determine Work Pad Requirements

Quazite offers work pads to accompany all of the traffic signal cabinet bases. If the cabinet is to be installed on a surface other than a sidewalk, a work pad may be necessary to provide stable, dry footing.

An alternative option to using a flat work pad in front of the traffic signal cabinet base is to use an enclosure instead. An enclosure serves as a splice box and the work pad also provides a skid resistant walking surface. Quazite offers a wide variety of enclosure sizes and depths to choose from. Your local QUAZITE® representative is available to assist you in selecting the appropriate enclosure and options to suit your application.



Many Departments of Transportation choose QUAZITE® traffic signal cabinet bases when they have projects requiring new and retrofit installations of traffic control cabinets. QUAZITE® traffic signal cabinet bases are less expensive than concrete to install, can be quickly installed by employees, can be relocated and can reduce potential injury and/or liability if struck by a vehicle.

In this particular application, the DOT had previously poured concrete in place at an approximate cost of \$1,000 for each traffic signal foundation. The installation process using concrete could take up to a week or more depending on weather and involved having to schedule around other work crews. The cost of the QUAZITE® base was \$500 (1/2 the cost of the alternative method) and installation time was reduced to one-half day.

Information shown in catalog is a partial listing. If pad or throat size desired is not listed, contact Quazite field sales office.



Traffic Signal Cabinet Base Cross Reference Guide

To Select the Traffic Signal Cabinet Base You Need for Your Application:

- 1 Determine Type of Cabinet
- 2 Determine Work Pad Requirements
- 3 Determine Performance Requirements
- 4 Determine Installation Requirements

NEMA Cabinets

Type	Bolt Pattern	New Part. No.	Old Part. No.
M	CL x 12	PB24360612B18	PB2436BA18
P	40 3/4" x 18 1/2"	PB40440608B15 PB40440608B24 PB40580616B24	PB4044BA15 PB4044BA24 PB4058BA24
P-38	34 1/2" x 18 1/2"	PB40440608B15 PB40440608B24 PB40580616B24	PB4044BA15 PB4044BA24 PB4058BA24
P-44	40 3/4" x 18 1/2"	PB40440608B15 PB40440608B24 PB40580616B24	PB4044BA15 PB4044BA24 PB4058BA24
R	40 3/4" x 18 1/2"	PB40440608B15 PB40440608B24 PB40580616B24	PB4044BA15 PB4044BA24 PB4058BA24
R-38	34 1/2" x 18 1/2"	PB40440608B15 PB40440608B24 PB40580616B24	PB4044BA15 PB4044BA24 PB4058BA24
R-44	40 3/4" x 18 1/2"	PB40440608B15 PB40440608B24 PB40580616B24	PB4044BA15 PB4044BA24 PB4058BA24

170 Controllers

Type	Bolt Pattern	New Part. No.	Old Part. No.
330	17" x 12 1/2"	PB24360612B18	PB2436BA18
332	25" x 15"	PB40440608B15 PB40440608B24 PB40580616B24	PB4044BA15 PB4044BA24 PB4058BA24
334	25" x 15"	PB40440608B15 PB40440608B24 PB40580616B24	PB4044BA15 PB4044BA24 PB4058BA24
336	15" x 6"	PB25251212B24	PB2525BA24
336 (A & S)	15" x 6"	PB25251212B24	PB2525BA24

Safetran #170

Type	Bolt Pattern	New Part. No.	Old Part. No.
334C	15" x 6"	PB25251212B24	PB2525BA24

Signal Control

Type	Bolt Pattern	New Part. No.	Old Part. No.
336/332	15" x 6"	PB25251212B24	PB2525BA24

Southern Cabinets

Type	Bolt Pattern	New Part. No.	Old Part. No.
IV	26 1/2" x 13 1/2"	PB24360612B18	PB2436BA18
V	30" x 18"	PB40580616B24	PB4058BA24
V-44	40 3/4" x 18 1/2"	PB40440608B15 PB40440608B24 PB40580616B24	PB4044BA15 PB4044BA24 PB4058BA24
VI	30" x 18"	PB40580616B24	PB4058BA24
332	25" x 15"	PB25251212B24	PB2525BA24
	25" x 15"	PB40580616B24	PB4058BA24
336S	15" x 15"	PB25251212B24	PB2525BA24
336	15" x 15"	PB25251212B24	PB2525BA24

Flextronics Enclosure Systems (Chatham Technologies)

Cabinet	Part No.	NEMA/ 170 Ref.	New Part No.	Old Part No.	
Double Door	DD363213	—	PB40440608B15 PB40440608B24	PB4044BA15 PB4044BA24	
	DD483615	—	PB40440608B15 PB40580616B24	PB4044BA15 PB4058BA24	
	DD604415	—	PB40580616B24 PB40440608B24	PB4058BA24 PB4044BA24	
	DD724818	—	PB40580616B24 PB40440608B24	PB4058BA24 PB4044BA24	
Front & Rear Door	DD604830	—	PB40580616B24	PB4058BA24	
	FR363624	—	PB40440608B15 PB40440608B24	PB4044BA15 PB4044BA24	
	FR773826	P-38, R-38	PB40580616B24	PB4058BA24	
	FR774426	R or P	PB40440608B15 PB40440608B24 PB40580616B24	PB4044BA15 PB4044BA24 PB4058BA24	
Rack Mount	RM392420	336	PB25251212B24	PB2525BA24	
	RM462420	336	PB25251212B24	PB2525BA24	
	RM672438	—	PB40440608B15 PB40440608B24	PB4044BA15 PB4044BA24	
	RM463026	—	PB40440608B15 PB40440608B24	PB4044BA15 PB4044BA24	
Pedestal	RM553026	—	PB40440608B15 PB40440608B24	PB4044BA15 PB4044BA24	
	PE401615	—	PB40440608B15 PB40440608B24	PB4044BA15 PB4044BA24	
	Large Single Door	LS301815	2B	PB24360612B18	PB2436BA18
		LS362015	3B	PB24360612B18	PB2436BA18
LS412516		G	PB24360612B18	PB2436BA18	
LS503017		M	PB24360612B18	PB2436BA18	
Quad Door	LS583017	MSX	PB24360612B18	PB2436BA18	
	LS763017	MXX	PB24360612B18	PB2436BA18	
	LS503617	M36	PB40440608B15 PB40440608B24	PB4044BA15 PB4044BA24	
	LS723618	—	PB40440608B15 PB40440608B24	PB4044BA15 PB4044BA24	
	LS363624	—	PB40440608B15 PB40440608B24	PB4044BA15 PB4044BA24	
	LS443624	—	PB40440608B15 PB40440608B24	PB4044BA15 PB4044BA24	
	LS553826	P-38	PB40580616B24	PB4058BA24	
	LS773826	R-38	PB40580616B24	PB4058BA24	
	LS554426	P-44	PB40440608B15 PB40440608B24 PB40580616B24	PB4044BA15 PB4044BA24 PB4058BA24	
	LS774426	R-44	PB40440608B15 PB40440608B24 PB40580616B24	PB4044BA15 PB4044BA24 PB4058BA24	
	QD774826	—	PB40580616B24	PB4058BA24	
	QD484836	—	PB40580616B24	PB4058BA24	
QD605036	—	PB40580616B24	PB4058BA24		
QD605636	—	PB40580616B24	PB4058BA24		

If your cabinet is not listed here, please contact your local QUAZITE® representative for additional sizes and insert configurations.

Information shown in catalog is a partial listing. If pad or throat size desired is not listed, contact Quazite field sales office.

JANUARY 2011



TRANSPORTATION INDUSTRY
PRODUCTS



Traffic Signal Cabinet Base Cross Reference Guide

Erpel (EDC)

Cabinet	Part No.	NEMA/ 170 Ref.	New Part No.	Old Part No.	
Double Door	DBL363213	—	PB40440608B15	PB4044BA15	
			PB40440608B24	PB4044BA24	
	DBL483615	—	PB40440608B15	PB4044BA15	
			PB40440608B24	PB4044BA24	
	DBL604415	—	PB40580616B24	PB4058BA24	
	DBL724818	—	PB40580616B24	PB4058BA24	
	DBL724824	—	PB40580616B24	PB4058BA24	
	DD604830	—	PB40580616B24	PB4058BA24	
Flush Door	FD503119	—	PB40440608B15	PB4044BA15	
			PB40440608B24	PB4044BA24	
	FD553826	—	PB40440608B15	PB4044BA15	
			PB40440608B24	PB4044BA24	
	FD773826	—	PB40440608B15	PB4044BA15	
			PB40440608B24	PB4044BA24	
	FD554426	—	PB40580616B24	PB4058BA24	
	FD774426	—	PB40580616B24	PB4058BA24	
Front & Rear Door	FDR363624	—	PB40440608B15	PB4044BA15	
			PB40440608B24	PB4044BA24	
	FDR443624	—	PB40440608B15	PB4044BA15	
			PB40440608B24	PB4044BA24	
	FDR773826	—	PB40440608B15	PB4044BA15	
			PB40440608B24	PB4044BA24	
	FDR774426	—	PB40580616B24	PB4058BA24	
Quad Door	LQD774826	—	PB40580616B24	PB4058BA24	
	LQD484836	—	PB40580616B24	PB4058BA24	
	LQD605036	—	PB40580616B24	PB4058BA24	
	LQD605636	—	PB40580616B24	PB4058BA24	
Pedestal Enclosure	TPE401608	—	PB24360612B18	PB2436BA18	
	TPE401615	—	PB25251212B24	PB2525BA18	
Large Single Door	LSD301815	2B	PB24360612B18	PB2436BA18	
	LSD362015	3B	PB24360612B18	PB2436BA18	
	LSD412516	G	PB24360612B18	PB2436BA18	
	LSD512516	K	PB24360612B18	PB2436BA18	
	LSD503017	M	PB24360612B18	PB2436BA18	
	LSD583017	MSX	PB24360612B18	PB2436BA18	
	LSD763017	MXX	PB24360612B18	PB2436BA18	
	LSD503617	M36	PB40440608B15	PB4044BA15	
			PB40440608B24	PB4044BA24	
		LSD723617	—	PB40440608B15	PB4044BA15
				PB40440608B24	PB4044BA24
		LSD363624	—	PB40440608B15	PB4044BA15
				PB40440608B24	PB4044BA24
		LSD443624	—	PB40440608B15	PB4044BA15
				PB40440608B24	PB4044BA24
		LSD553826	P-38	PB40580616B24	PB4058BA24
	LSD773826	R-38	PB40580616B24	PB4058BA24	
	LSD554426	P-44, R-44	PB40440608B15	PB4044BA15	
			PB40440608B24	PB4044BA24	
	LSD774426	R-44	PB40440608B15	PB4044BA15	
			PB40440608B24	PB4044BA24	
Rack Mount	ERM392421	336	PB25251212B24	PB2525BA24	
	ERM462421	336	PB25251212B24	PB2525BA24	
	ERM463027	—	PB40440608B15	PB4044BA15	
			PB40440608B24	PB4044BA24	
	ERM553027	—	PB40440608B15	PB4044BA15	
			PB40440608B24	PB4044BA24	
	ERM672430	332	PB40440608B15	PB4044BA15	
			PB40440608B24	PB4044BA24	
		332	PB40580616B24	PB4058BA24	
	ERM672438	—	PB40440608B15	PB4044BA15	
			PB40440608B24	PB4044BA24	

To Select the Traffic Signal Cabinet Base You Need for Your Application:

- 1 Determine Type of Cabinet
- 2 Determine Work Pad Requirements
- 3 Determine Performance Requirements
- 4 Determine Installation Requirements

TRANSPORTATION INDUSTRY PRODUCTS

If your cabinet is not listed here, please contact your local QUAZITE® representative for additional sizes and insert configurations.

Information shown in catalog is a partial listing. If pad or throat size desired is not listed, contact Quazite field sales office.



Traffic Signal Cabinet Base Selection Guide

To Select the Traffic Signal Cabinet Base You Need for Your Application:

- 1 Determine Type of Cabinet
- 2 Determine Work Pad Requirements
- 3 Determine Performance Requirements**
- 4 Determine Installation Requirements

3 Determine Performance Requirements

QUAZITE® traffic signal cabinet bases are constructed of strong polymer concrete and reinforced with a heavy-weave fiberglass. Unlike concrete bases, polymer concrete bases are frangible and will break away when subjected to severe impact. This feature helps reduce the risk of serious injury or fatalities resulting from these incidents.

QUAZITE® polymer concrete traffic signal cabinet bases also resist UV rays, chemicals and water absorption. Concrete bases are susceptible to damage caused by freeze/thaw cycles. Thermoplastic fiberglass bases can become brittle and eventually crack when exposed to the weather. The durability that QUAZITE® provides means lower maintenance and life cycle costs.

Traffic Signal Cabinet Base Performance

Performance Criteria	QUAZITE®				
	Precast Polymer Concrete Bases	Precast Concrete Bases	Poured-in-Place Concrete Bases	Thermoplastic / Fiberglass Bases	Aluminum and Steel Bases
Stable under loading during high temperatures (won't flex or warp)	X	X	X		X
Stable under loading during cold temperatures (won't crack)	X				X
Not susceptible to damage caused by freeze/thaw cycles	X			X	X
Resistant to corrosion caused by weathering, road chemicals and equipment lubricants	X			X	
Provides long-term durability (fatigue or creep resistant)	X	X	X		X
Frangible base will break away when cabinet is struck by a vehicle	X			X	

TRANSPORTATION INDUSTRY PRODUCTS



Information shown in catalog is a partial listing. If pad or throat size desired is not listed, contact Quazite field sales office.

JANUARY 2011



Traffic Signal Cabinet Base Selection Guide

To Select the Traffic Signal Cabinet Base You Need for Your Application:

- 1 Determine Type of Cabinet
- 2 Determine Work Pad Requirements
- 3 Determine Performance Requirements
- 4 Determine Installation Requirements**

4 Determine Installation Requirements

Installing QUAZITE® traffic signal cabinet bases is easy and cost effective because it requires no special equipment to set the base. A backhoe is all that is necessary to lift the base in place. QUAZITE® traffic signal cabinet bases also save time during installation. Unlike poured-in-place bases that take days to form, pour, set and remove the forms, QUAZITE® traffic signal cabinet bases can be installed quickly, allowing the cabinet and equipment installation to begin immediately after setting the base. For detailed instructions on how to install QUAZITE® traffic signal cabinet bases, see page 100.

Traffic Signal Cabinet Base Installation

Installation Criteria	QUAZITE®				
	Precast Polymer Concrete Bases	Precast Concrete Bases	Poured-in-Place Concrete Bases	Thermoplastic / Fiberglass Bases	Aluminum and Steel Bases
Easily installed in areas with limited accessibility	X			X	X
Minimal planning and scheduling of crews required for installation	X			X	X
No special equipment (such as a boom truck or crane) needed for installation	X			X	X
Easily installed by no more than two crew members (light weight)	X			X	X
Cabinet and base can be easily installed in the same day	X	X		X	X

TRANSPORTATION INDUSTRY PRODUCTS

Pad Numbering System

Weight	Style	Size	Throat Size	Item	Depth	Surface
P	L	4846 48" x 46"	0817 8" x 17"	A	3 3" thick	T S - Smooth T - Skid resistant
L - Lightweight mix P - Standard mix	B - Box pad H - Electrical equipment pad J - Split electrical equipment pad K - Split telecommunications equipment pad L - Telecommunications equipment pad	Dimensions run parallel to each other.		A - 3/8-16 UNC inserts B - 1/2-13 UNC inserts C - 5/8-11 UNC inserts E - 5/8 thru hole F - Struts w/ 3/8" inserts G - Struts w/ 1/2" inserts H - Struts w/ 5/8" inserts	(Indicates surface thickness if flat pad; indicates depth if box pad.)	

Information shown in catalog is a partial listing. If pad or throat size desired is not listed, contact Quazite field sales office.



SPECIFICATIONS/DATA

Traffic Signal Cabinet Bases

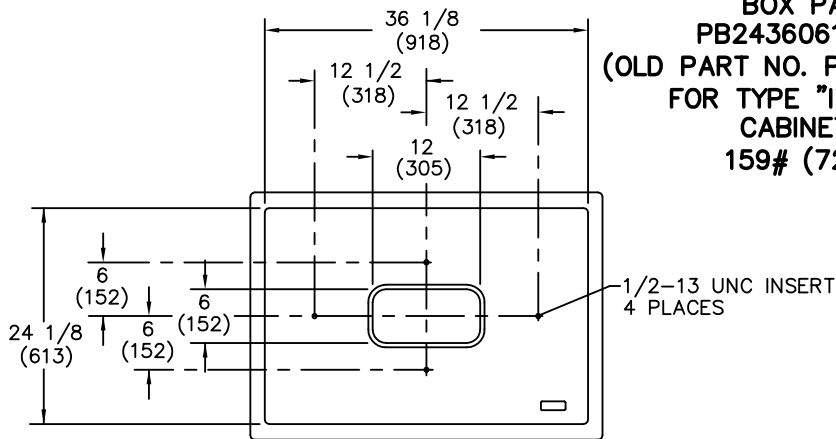

BOX PAD
PB24360612B18
 (OLD PART NO. PB2436BA18)
 FOR TYPE "IV & M"
 CABINETS
 159# (72.1)

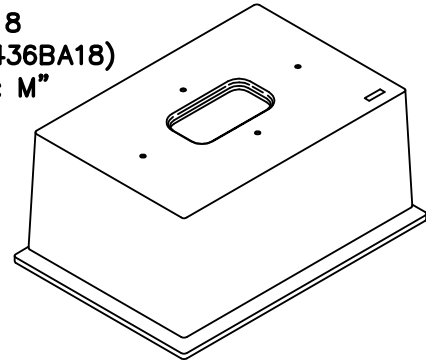

1/2-13 UNC INSERT
 4 PLACES

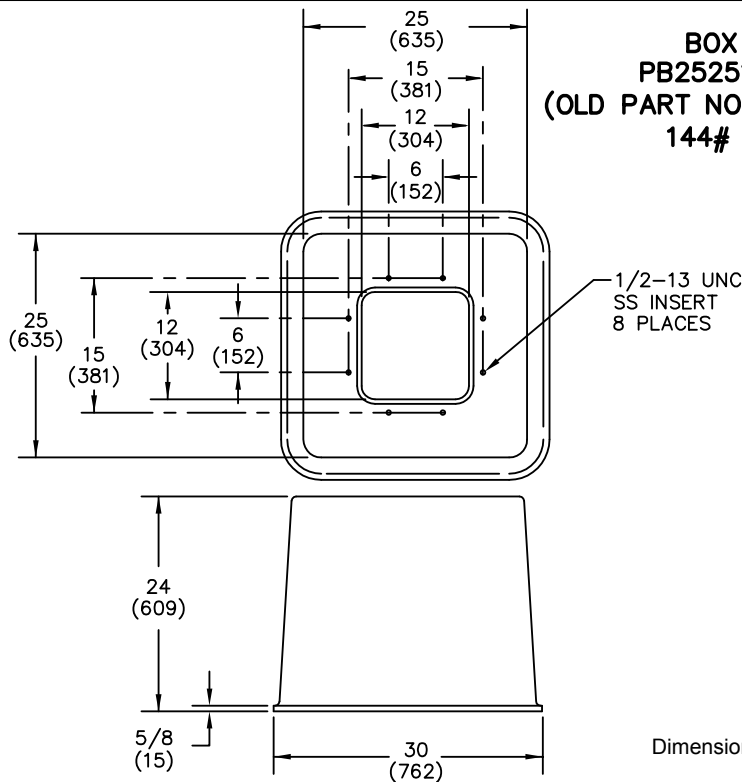
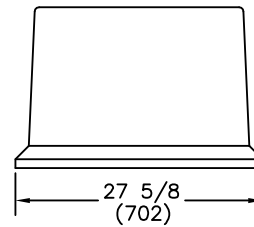
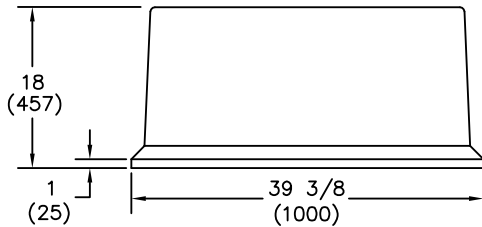

BOX PAD
PB25251212B24
 (OLD PART NO. PB2525BA24)
 144# (66.3)

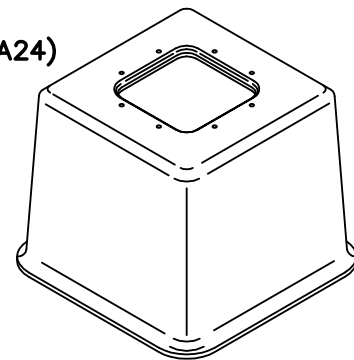

1/2-13 UNC
 SS INSERT
 8 PLACES

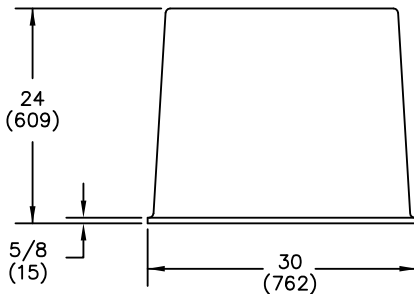

Dimensions and weights in parentheses are metric equivalent.

Information shown in catalog is a partial listing. If pad or throat size desired is not listed, contact Quazite field sales office.

JANUARY 2011



SPECIFICATIONS/DATA

Traffic Signal Cabinet Bases

NEW PART NO.	OLD PART NO.	WEIGHT #	DIM. A	DIM. B	DIM. C
PB40440608B15	PB4044BA15	281 (127.0 kg)	6" (152 mm)	8" (203 mm)	15" (381 mm)
PB40440608B24	PB4044BA24	378 (171.0 kg)	6" (152 mm)	8" (203 mm)	24" (610 mm)
PB40440928B24	PB4044B503	385 (174.6 kg)	9" (229 mm)	28" (711 mm)	24" (610 mm)
PB40441218B24	PB4044B501	366 (166 kg)	12" (305 mm)	18" (457 mm)	24" (610 mm)

Refer to Traffic Signal Cabinet Base Cross Reference Guide on pages 81 - 82.

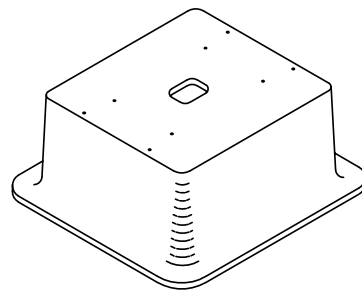
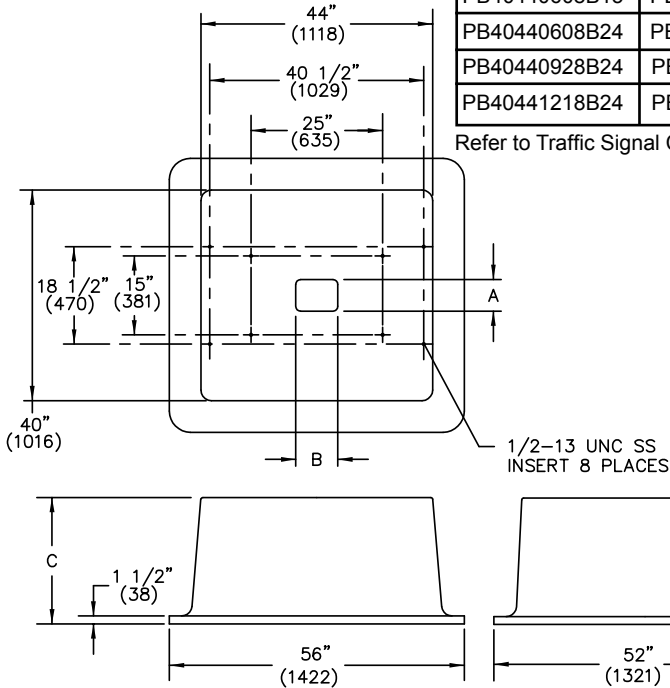

TRANSPORTATION INDUSTRY PRODUCTS

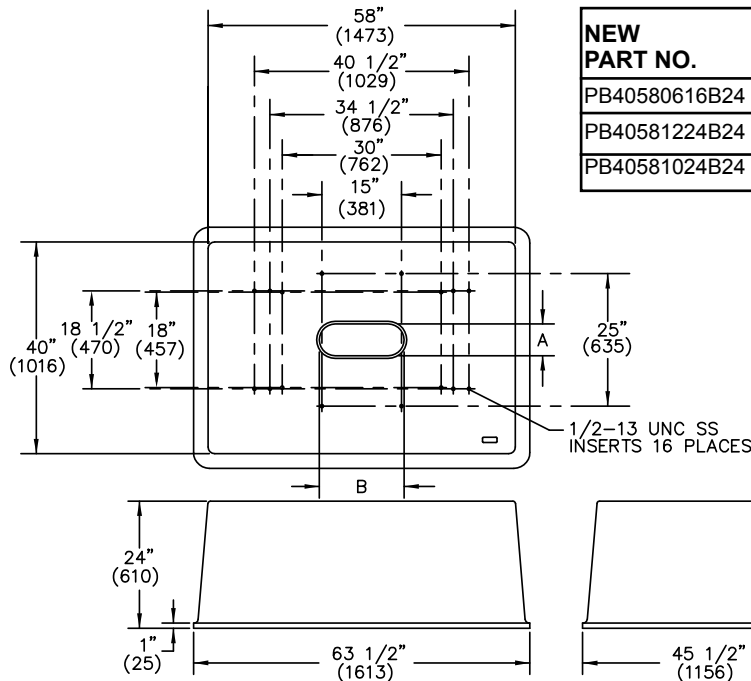

NEW PART NO.	OLD PART NO.	WEIGHT #	DIM. A	DIM. B
PB40580616B24	PB4058BA24	450 (204.1 kg)	6" (152 mm)	16" (406 mm)
PB40581224B24	PB4058B502	435 (197.3 kg)	12" (305 mm)	24" (610 mm)
PB40581024B24	PB4058B504	440 (199.6 kg)	10" (254 mm)	24" (610 mm)

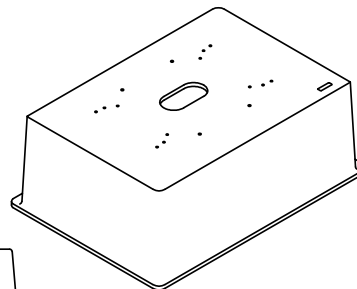

Dimensions and weights in parentheses are metric equivalent.

Information shown in catalog is a partial listing. If pad or throat size desired is not listed, contact Quazite field sales office.

JANUARY 2011



SPECIFICATIONS/DATA

Combination Traffic Signal/Battery Backup Cabinet Base

BOX PAD
PB40441323A24
FOR 332A TRAFFIC SIGNAL
CONTROLLER AND
BATTERY BACKUP SYSTEM
389# (176)

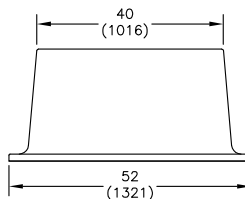
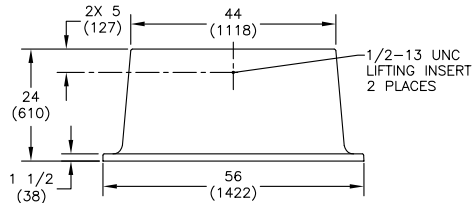
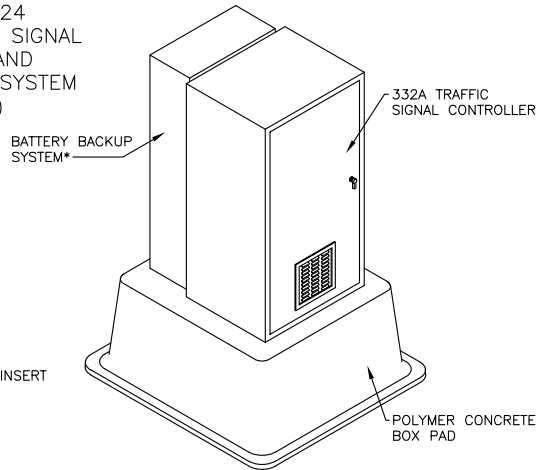
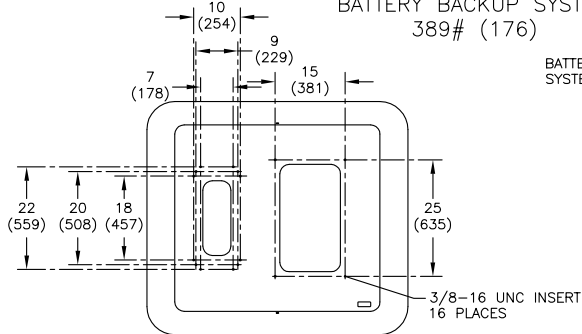

*Battery Backup System	
McCain	#M34196
Temple	#1101-4UPS
US Traffic	#BC280-CA-A-K2
Meyers	#BC280-CA-A-K2
Safetran Traffic Systems	#088397D332-00B

TRAFFIC SIGNAL CONTROLLER BASE WITH SELF-CONTAINED UPS BATTERY STORAGE

BOX PAD PART NUMBER	WEIGHT	ACCESSORIES
PB27452139502	232# (105)	- CABLE RACK STRAIN RELIEF SUPPORTS FOR CONDUCTORS
PB27452139500	232# (105)	- CABLE RACK & FULL STRAIN RELIEF SUPPORTS FOR CONDUCTORS
PB27452139501	244# (111)	- CABLE RACK & FULL STRAIN RELIEF SUPPORTS FOR CONDUCTORS - BATTERY SUPPORT GRATES (4)

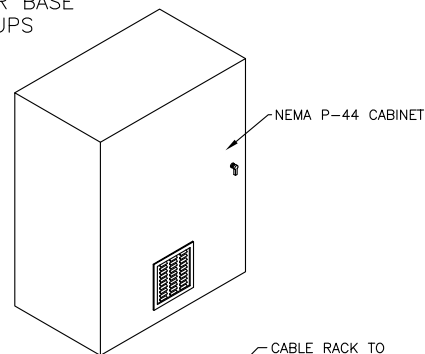

FULL STRAIN RELIEF CONDUCTOR SUPPORTS (PB27452139500 & 501)

CABLE RACK TO PROVIDE STRAIN RELIEF FOR INCOMING TERMINAL CONDUCTORS (4 PLACES) (PB27452139500, 501, & 502)

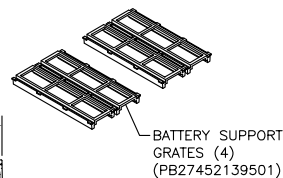
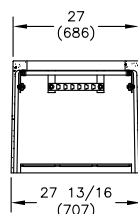
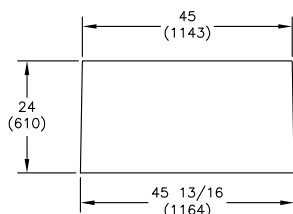
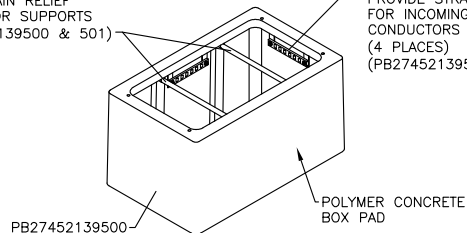
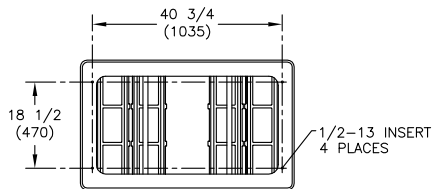

Information shown in catalog is a partial listing. If pad or throat size desired is not listed, contact Quazite field sales office.



Cabinet shown mounted to a Quazite® traffic signal base along with three Quazite® underground enclosures.

TRANSPORTATION INDUSTRY PRODUCTS

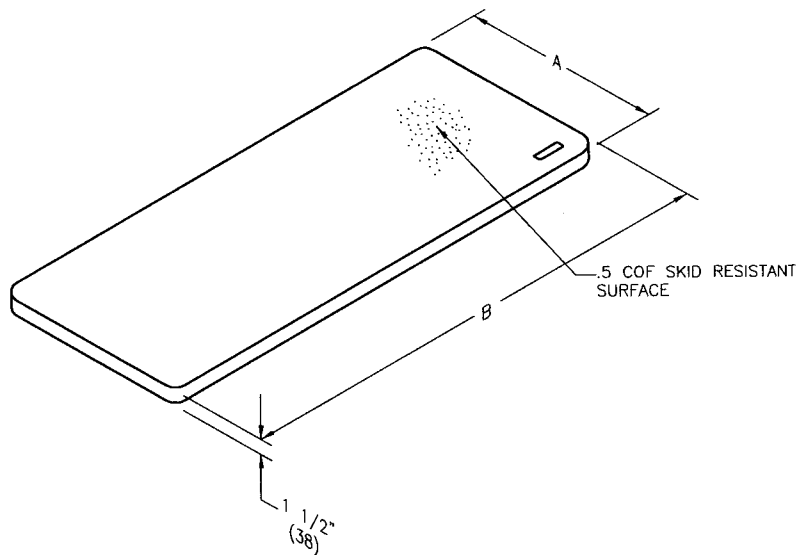

PART NO.	OLD PART NO.	WEIGHT #	DIMENSION A	DIMENSION B
PH242500002T	PH2425AA	70 (30.8 kg)	24" (610 mm)	25" (635 mm)
PH243600002T	PH2436AA	95 (43.1 kg)	24" (610 mm)	36" (914 mm)
PH244400002T	PH2444AA	120 (54.4 kg)	24" (610 mm)	44" (1118 mm)
PH245800002T	PH2458AA	160 (72.6 kg)	24" (610 mm)	58" (1473 mm)

Dimensions & weights in parentheses are metric equivalent.

SPECIFICATIONS/DATA

Median Barrier Enclosure

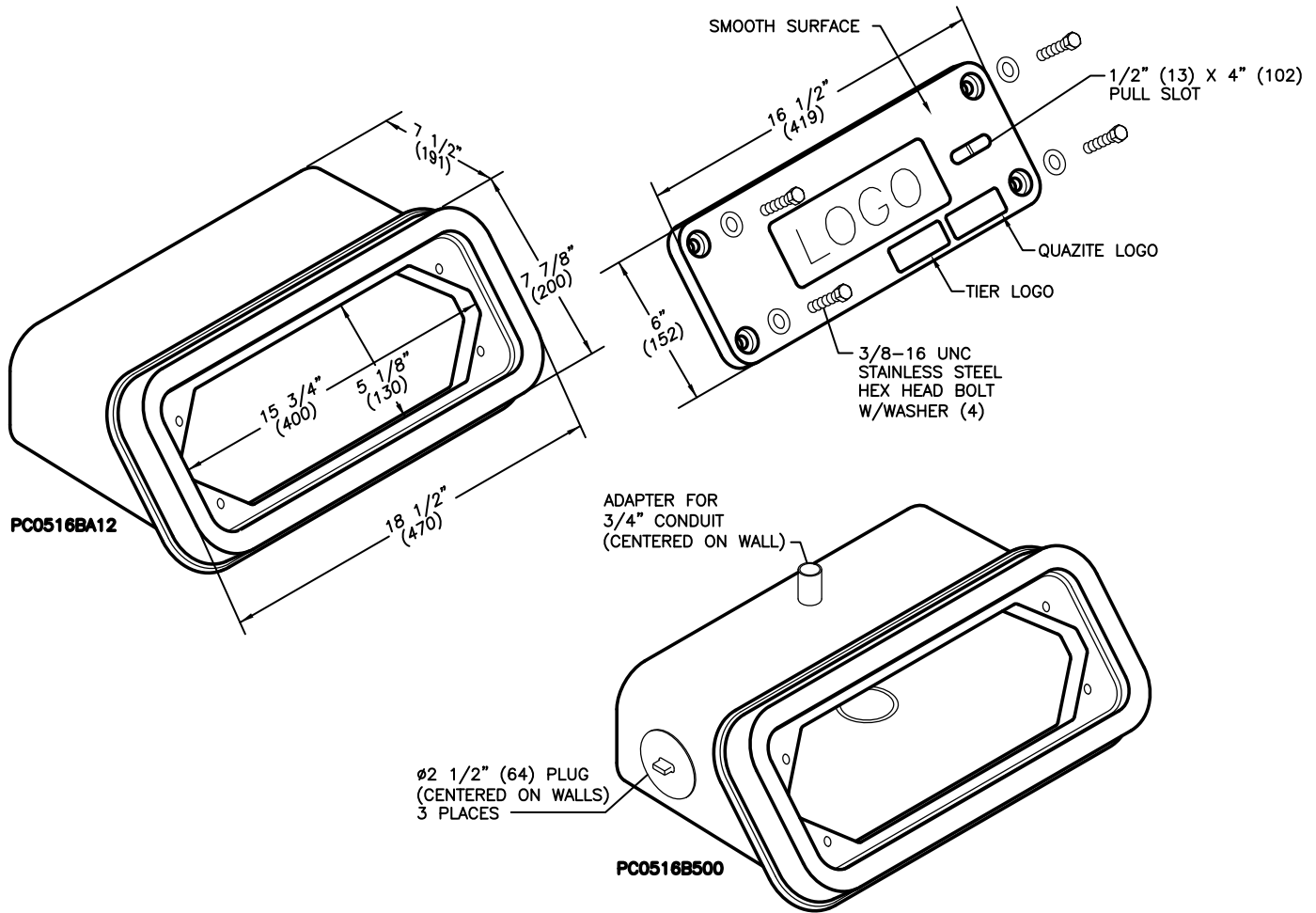

TRANSPORTATION INDUSTRY PRODUCTS

Cover (Blank unless logo is specified)

DESCRIPTION	PART NO.	WEIGHT #	DESIGN/TEST LOAD #	ANSI TIER*
W/4 Bolts	PC0516CA00	6 (2.7 kg)	8,000 / 12,000	8
W/2 Bolts	PC0516C500	6 (2.7 kg)	8,000 / 12,000	8

Box

DESCRIPTION	PART NO.	WEIGHT #	DESIGN/TEST LOAD #	ANSI TIER*
Closed Bottom	PC0516BA12	25 (11 kg)	15,000 / 22,500	15
Closed Bottom	PC0516B500	25 (11 kg)	15,000 / 22,500	15

Dimensions and weights in parentheses are metric equivalent.

* Loadings comply with ANSI/SCTE 77 (see page 9).



SPECIFICATIONS/DATA

Jersey Style Median Barrier Enclosure

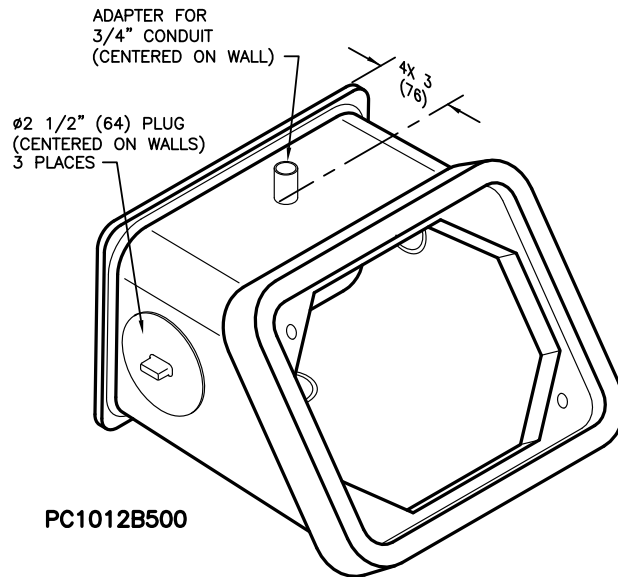
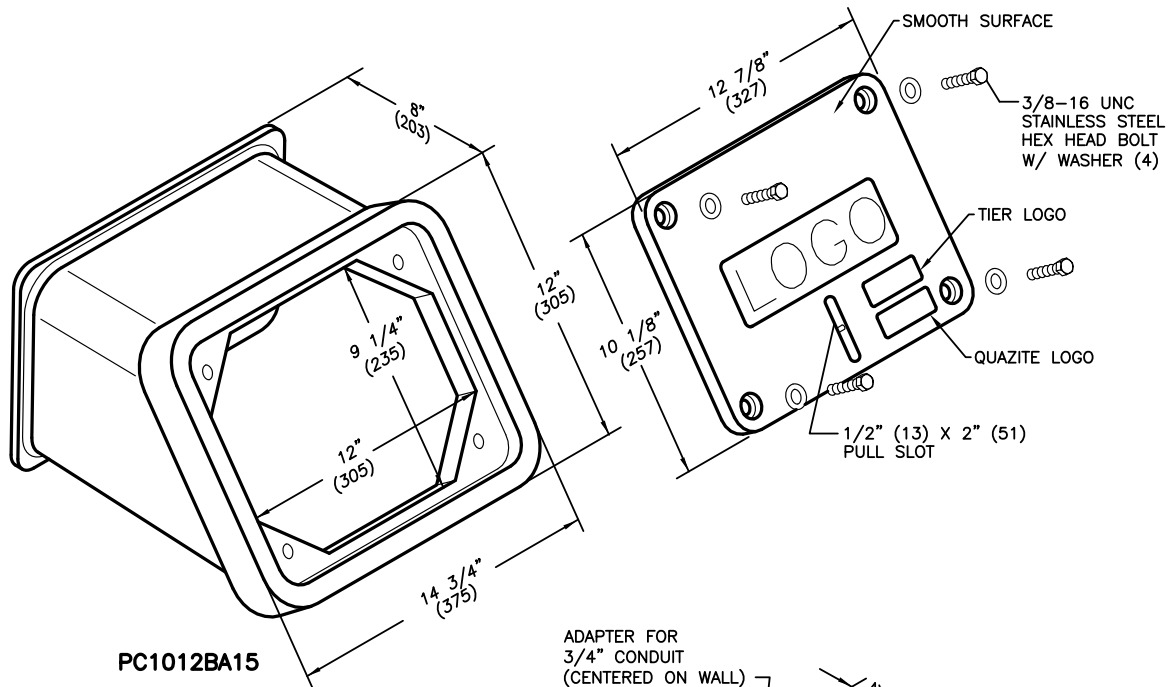

Cover (Blank unless logo is specified)

DESCRIPTION	PART NO.	WEIGHT #	DESIGN/TEST LOAD #	ANSI TIER*
W/4 Bolts	PC1012CA00	8 (3.6 kg)	8,000 / 12,000	8
W/2 Bolts	PC1012C500	8 (3.6 kg)	8,000 / 12,000	8

Box

DESCRIPTION	PART NO.	WEIGHT #	DESIGN/TEST LOAD #	ANSI TIER*
Solid Bottom	PC1012BA15	23 (10.4 kg)	15,000 / 22,500	15
Solid Bottom	PC1012B500	23 (10.4 kg)	15,000 / 22,500	15

Dimensions and weights in parentheses are metric equivalent.

* Loadings comply with ANSI/SCTE 77 (see page 9).

“ANSI TIER” SELECTION AND PLACEMENT IN NON-DELIBERATE VEHICULAR TRAFFIC APPLICATIONS

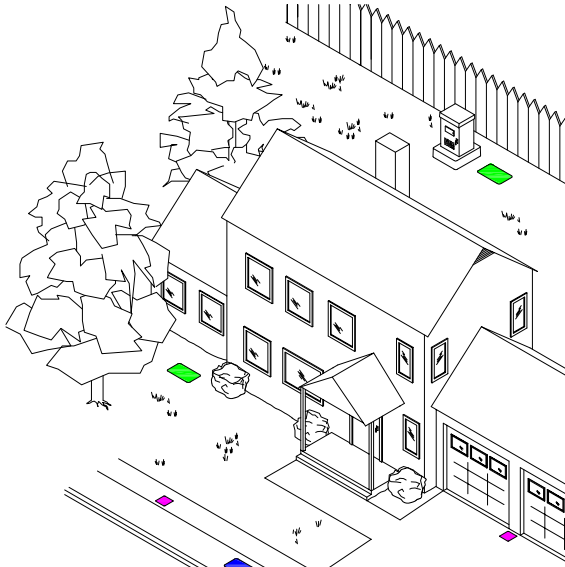

RESIDENTIAL (NON-DELIBERATE TRAFFIC)

Enclosures can be placed in grassy areas or sidewalks. They may also be placed in areas next to the structures or poles where it is unlikely a vehicle will run over the enclosure. Enclosures should not be placed in the street or driveway where deliberate traffic is anticipated.

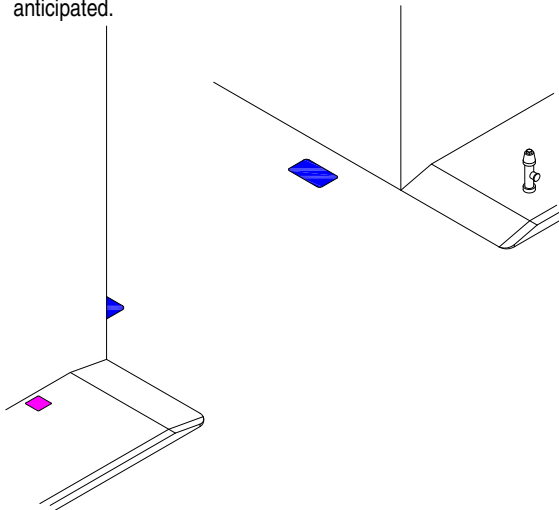

DUAL LANE ALLEY (NON-DELIBERATE TRAFFIC)

In a single lane alleyway (at right), the enclosure should be placed in the center of the alleyway. The placement minimizes the possibility of the enclosure being run over. In a dual lane alleyway, the enclosure should be placed as close to the building as possible. Most of the time, two vehicles will not be in the alleyway at the same time, so the chances of the enclosure getting run over will be minimal. Knowledge of the location and expected traffic patterns should be used to determine if traffic would be deliberate or non-deliberate as defined previously.

The enclosures shown in these sketches have been color coded to indicate the proper Tier level required for the application.

- Green = Pedestrian/Tier 5
- Magenta = Tier 8
- Blue = Tier 15 or 22

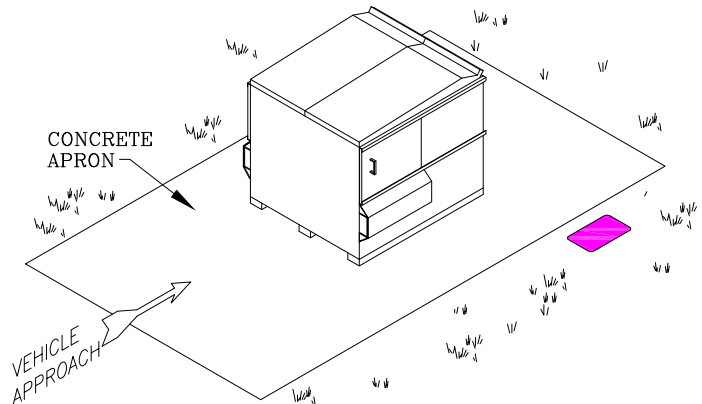

TRASH RECEPTACLE APPLICATION (NON-DELIBERATE TRAFFIC)

In an area where a trash receptacle is placed, the enclosure should be placed away from the concrete that the receptacle is set on so that the receptacle will not be placed on the enclosure or the wheels of the truck will not roll over the enclosure. Even though the traffic expected on the concrete apron or in front of the receptacle is occasional, it is deliberate because the traffic is both intentional and heavy in nature.

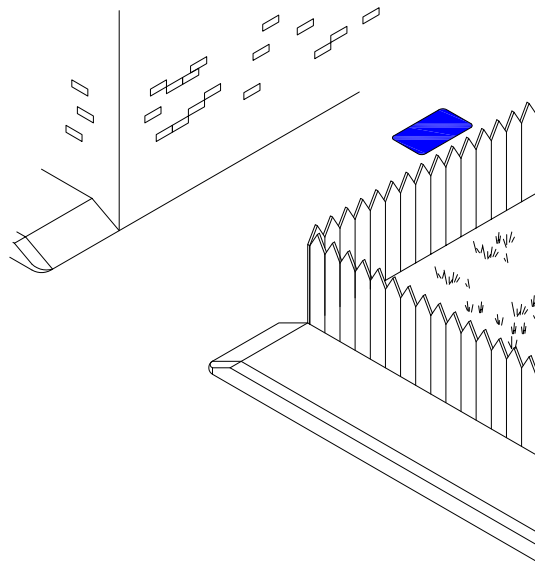

INSTALLATION

“ANSI TIER” SELECTION AND PLACEMENT IN NON-DELIBERATE VEHICULAR TRAFFIC APPLICATIONS

PARKING LOTS

(NON-DELIBERATE TRAFFIC)

Enclosure applications:

- In the front center of a parking space with the enclosure placed so that the tires of the vehicle will straddle the enclosure.
- In the grassy area where the parking lot ends.
- Placed along side and close to the lighting pole.
- Placed between the parking curbs where the possibility of running over the enclosure is remote. This enclosure could be placed anywhere between the parking curbs.
- Along the building but not in front of a door or pick up area where vehicular traffic would be expected.

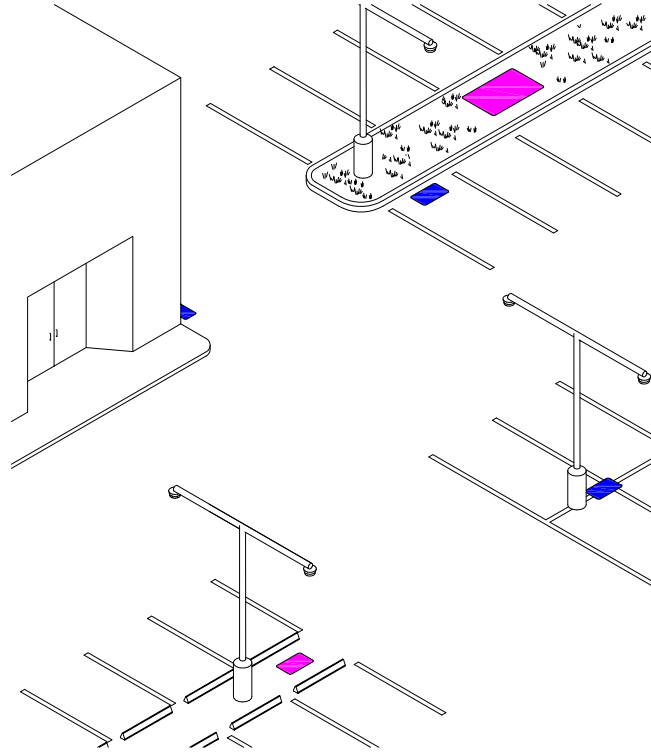
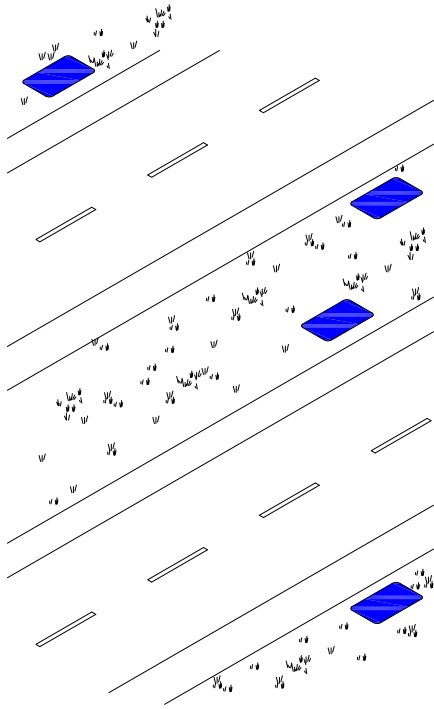

DIVIDED HIGHWAY

(NON-DELIBERATE TRAFFIC)

On a divided highway, the enclosure should be placed in any area that is not paved and where deliberate traffic is not expected. They can be placed in the grassy median or off the shoulder of the highway.

NOTE: The paved shoulder of the highway is normally considered a deliberate traffic location because it may be used as a breakdown lane or may be used as a lane in heavy traffic periods or in times of construction. Therefore, an enclosure should never be placed in the paved shoulder of a road or in the road itself. The enclosure should be placed off the shoulder, in the grassy areas.

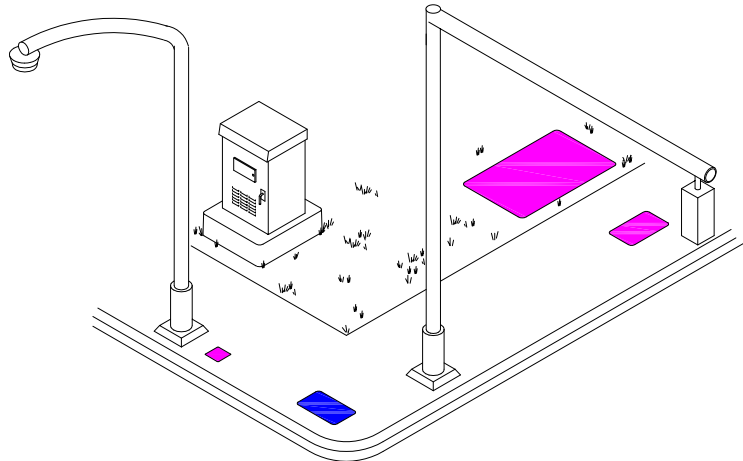

SIDEWALK & GRASSY AREA

(NON-DELIBERATE TRAFFIC)

An enclosure can be placed in any grassy area and in most sidewalks. However, an enclosure should not be placed in a sidewalk where a driveway crosses over the sidewalk.

Standard Small Enclosure Installation

Installation Guidelines for Enclosures Sized 17" x 30" and Smaller:

1. Prepare the Excavation

- 1.01 Excavate approximately 6 inches deeper than depth of the enclosure.
- 1.02 Add 6 inches of gravel or crushed rock for drainage.

2. Place Enclosure in Hole

- 2.01 Top of enclosure should be at grade level.

3. Fill and Compact Soil

- 3.01 Fill to grade level with cover in enclosure.

4. Grade Adjustment

- 4.01 If grade level is raised later, a straight sided enclosure can be pulled up and bricked at the bottom on one or four sides to conform to the landscape.



Excavate 6 inches deeper than the depth of the enclosure and add 6 to 8 inches of gravel or crushed rock (1.02).



The top of the enclosure should be level with the grade (2.01).



Make sure the cover is on when filling around the enclosure (3.01).

Hole Cutting Instructions

Methods for Cutting Holes in QUAZITE®

Enclosures:

Masonry Hole Saw

1. Drill a 7/8" pilot hole with a carbide tipped masonry drill.
2. Drill hole using a diamond tipped masonry hole saw.
 - This is the preferred method from engineering.
 - Estimated drilling time is 1 - 1.5 minutes.



Knockout Punch Driver

1. Set up the punch

- 1.01 Slide the die over the pull rod.
- 1.02 Insert pull rod into pilot hole.
- 1.03 Thread the punch onto the pull rod.

2. Punch hole and remove

- 2.01 Operate hand pump until the punch penetrates the surface.
- 2.02 Open pump release valve.
- 2.03 Remove the slug.

NOTE: UL Listed enclosures with holes drilled in the field may qualify for UL Listing as long as the holes do not exceed more than 25% of the area of each sidewall and as long as the holes do not cut into a structural reinforcing rib, corner, or box lip. Contact the factory if there is any question.

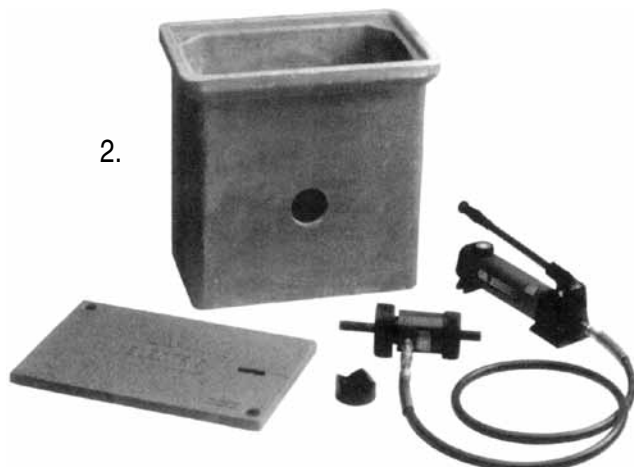
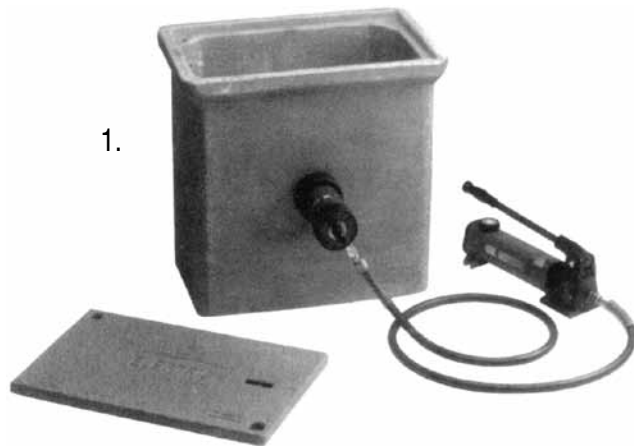

EZ-Nut and Self-Aligning Nut Cleaning & Replacement Instructions

Quazite has redesigned the EZ-Nut assembly (Style "B") to provide a 40% greater drainage opening area and enable quicker and easier nut replacement. This Style "B" design will be included in new production, but existing inventories may have the older Style "A" EZ-Nut assembly. These instructions are provided in the event it is necessary to replace an existing nut.

*To determine which EZ-Nut design is in any box, insert a screwdriver into the drainage opening and pull upward. If the door does not pop open, the Style "A" EZ-Nut is in the box. Follow the instructions for the Style "A" design. If the door pops open, follow the instructions for the Style "B" EZ-Nut design.

Style "B" EZ-Nut replacement procedure*

1. Locate the drainage opening in the area containing the insert. Insert a screwdriver into the opening at approximately the angle shown in Figure 1.
2. After inserting the screwdriver into the drainage opening, pull upward on the handle of the screwdriver in order to pry open the door of the insert as shown in Figure 2.
3. If necessary, remove any remaining debris from the opening. After the opening is clear, remove existing nut and replace with a nut of the required size.

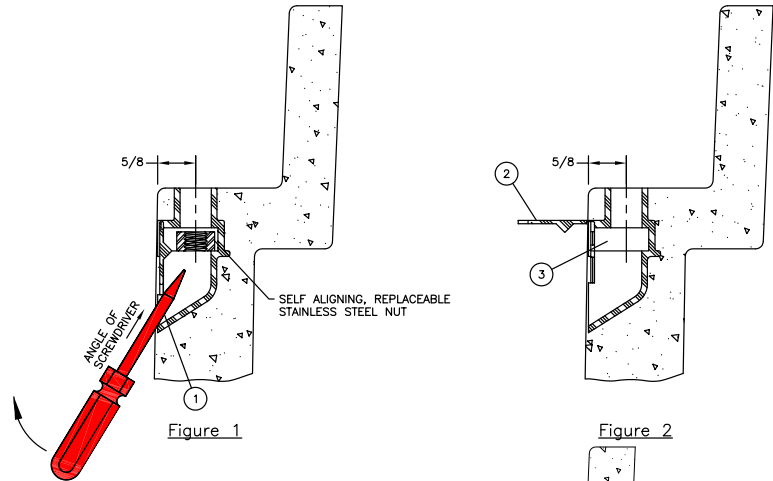

Style "A" EZ-Nut replacement procedure*

1. Measure 13/16" down from bearing ledge of the enclosure. Using a screwdriver and hammer, punch a hole into the cavity of the insert. Clear excess material out of the opening.
2. Insert a screwdriver into the top opening and push the 3/18-16 UNC square nut out of the opening just created. Replace with a new 3/8-16 UNC square nut and plug the cavity in the sidewall if necessary.

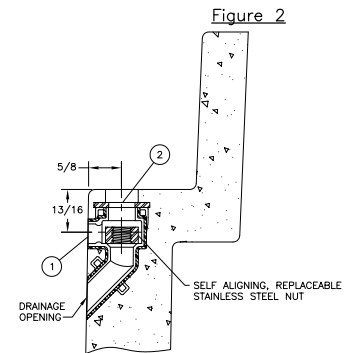

EZ-Nut Cleanout Procedure

1. Make certain drain hole is clear. If it is not, scrape off material with a flat edge and remove any visible obstruction(s). The drain hole is located approximately 2" below the bearing ledge.
2. Insert flat head screw driver into insert. Scrape dirt off of threads and clean out any excess dirt.
3. (Optional) Spray WD-40® or equivalent lubricant into insert to lubricate the threads and help loosen any remaining debris.
4. Replace cover and secure bolts into insert.

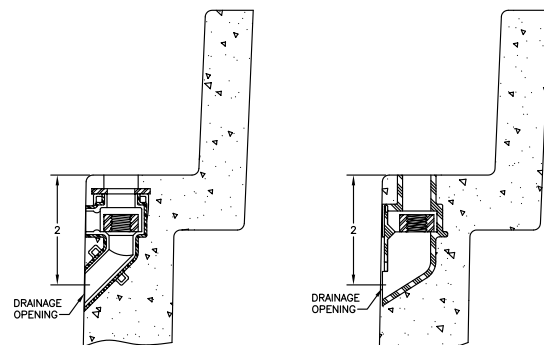

Self-Aligning Nut Replacement:

1. Remove screws using a phillips screwdriver. Then remove the retainer clip.
2. Remove 1/2-13 UNC square nut and replace it with a new 1/2-13 UNC square nut.
3. Replace the retainer clip and screws.

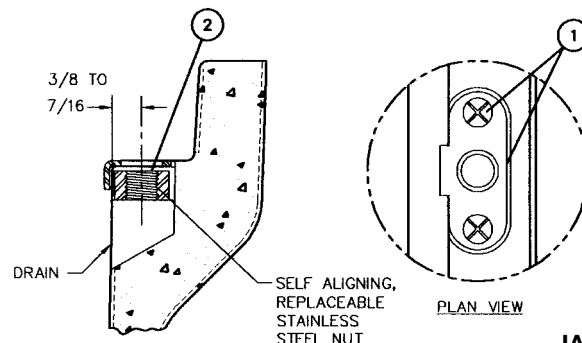

INSTALLATION

Standard Large Enclosure Installation

Installation Guidelines for Enclosures Sized 24" x 36" and Larger:

1. Select an appropriate site or location for an underground enclosure

- 1.01 Utility easements
- 1.02 Streets
- 1.03 Parking lots
- 1.04 Parking lot entrances
- 1.05 Shipping & delivery docks
- 1.06 Waste removal (dumpsters)

2. Place conduit or water pipes

- 2.01 Trenching or plowing of conduit
- 2.02 Boring under road crossings & railroads
- 2.03 Mark depth of conduit (marker tape)

3. Excavate enclosure hole

- 3.01 Make hole 1-2' longer and wider than the box and 6"-8" deeper than the enclosure (add a rodent barrier if called for).

4. Prepare the enclosure for placement

- 4.01 Unpalletize the enclosure.
- 4.02 Place nylon straps or chains around the lifting bolts and secure to the backhoe bucket. The angle between the strap and the enclosure should not be less than 45 degrees.
- 4.03 Lift the enclosure and place it into the hole.
- 4.04 Place gravel in the enclosure and around the side if necessary.
- 4.05 Lift the enclosure to the proper elevation allowing the gravel to run out under the enclosure.
- 4.06 Check the elevation of the enclosure with a level and range pole.
- 4.07 Make the necessary elevation adjustments with the bucket and recheck the elevation.
- 4.08 Once the enclosure is set to the proper elevation, remove the lifting bolts, reinstall the covers and back fill.
- 4.09 If 95% compaction is required, internal bracing should be used on all manufacturer's enclosures to prevent deflection and premature failure.



Attach nylon straps or chains to the lifting bolts (4.02).



Lift and position enclosure with backhoe (4.03).



Place gravel in the enclosure and around the side. Lift enclosure to let gravel run underneath (4.04, 4.05).

Internal Bracing Installation

Installation Guidelines for Internal Bracing:

Internal bracing may be warranted for any manufacturer's underground enclosure. If 95% compaction is required or if heavy vehicles are going to be present during construction and/or throughout the life of the enclosure, internal bracing during back-filling operations will ensure minimal box sidewall deflections. This installation practice applies to enclosures made from any material to maintain the original sidewall geometry.

Supports should be 2 x 4s or similar material sized to hold at mid-depth.

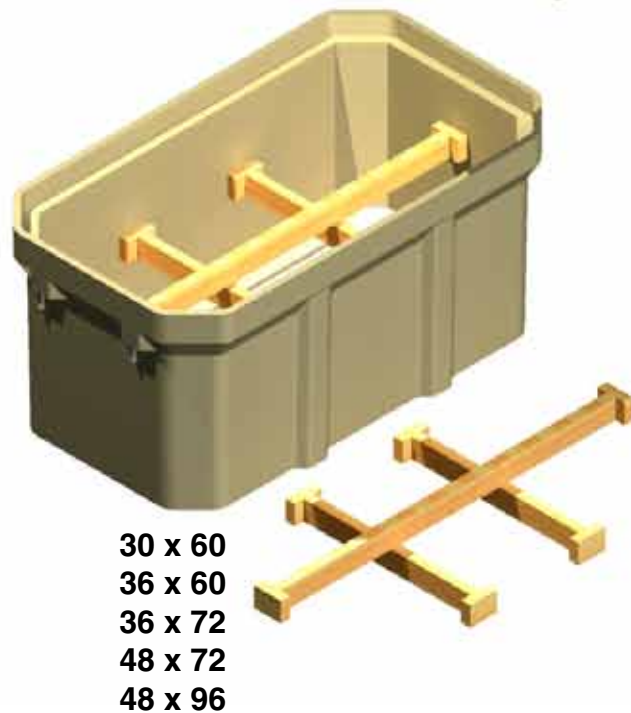
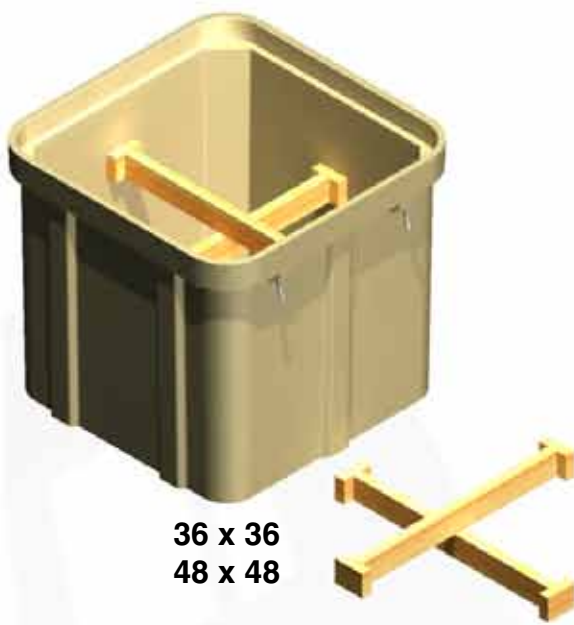
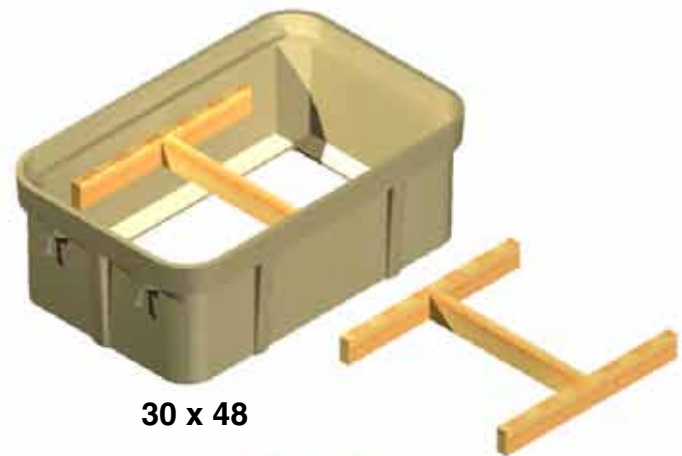

Concrete Collar Applications



Concrete collars may be desired for installations in driveways, parking lots and off-roadway applications where subject to occasional non-deliberate traffic. This applies to boxes made from any material to provide added protection for the top lip. This is not necessary in grassy areas or areas subject to pedestrian traffic.

Notes:

1. Concrete encasement to be 3,000 psi minimum.
2. Concrete encasement collar dimension, D, to be equal to design pavement depth.
3. Pavement and subgrade to be as shown on the engineering plans.

INSTALLATION

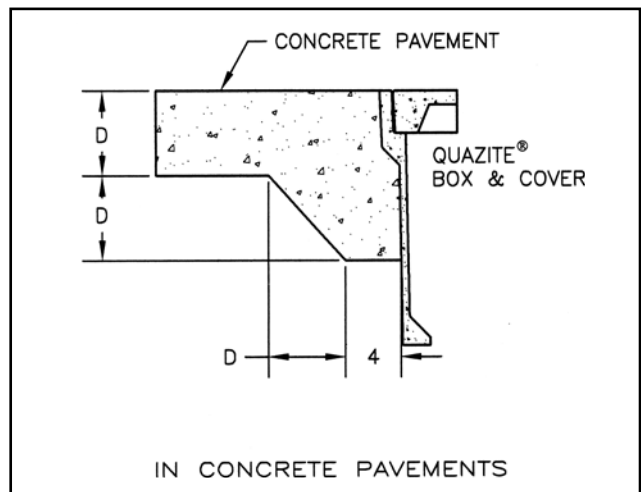
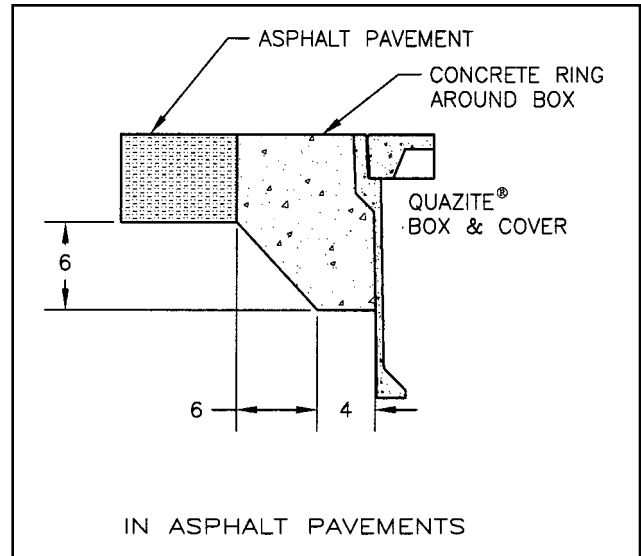
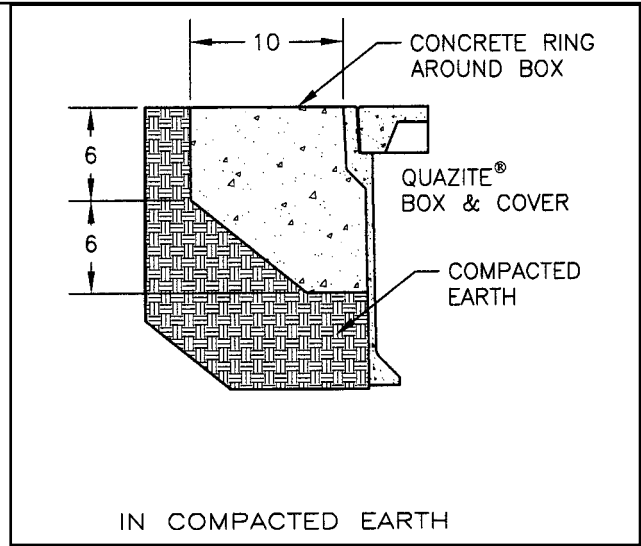

Telecommunications Cabinet Pad Installation

Installation Instructions

1. General

- 1.01 This section covers the description, installation and use of support pads for cross connect cabinets and other pedestal type cabinets.
- 1.02 The foundation base is designed for use with most cabinets now being used in the field.

2. Description and Use

- 2.01 The foundation pad is constructed of polymer concrete and reinforced with a heavy-weave fiberglass. All pads have a non-skid surface.
- 2.02 Various types and sizes of pads are available for use depending on the size of the cabinet to be installed.
- 2.03 3/8" or 1/2" inserts (anchors) or struts are molded into the pad and must align with the base of the cabinet base lugs, or support leg sets.

3. Installation

- 3.01 The following installation procedure is the same for all sizes of foundation pads.
- 3.02 Determine cable/conduit entry position.
- 3.03 Dig recess for pad so that top surface of pad will be level with surrounding area.
- 3.04 Level dirt around cable opening.
- 3.05 Level and tamp down dirt in the area to be occupied by the foundation pad.
- 3.06 Backfill and tamp in trench area leading to cable opening.
- 3.07 Place pad in prepared, level area with opening in pad (throat) directly over cable entry position.
- 3.08 Remove yellow plastic protective covers from inserts by turning counterclockwise. Discard.
- 3.09 Attach cabinet to the foundation pad with bolts, brackets, and/or lugs provided by cabinet manufacturer.
- 3.10 Backfill and tamp earth around pad so it is level with surrounding landscape.



Traffic Signal Cabinet Base Installation

Installation Instructions

1. General

- 1.01 This section covers the description, installation and use of traffic signal cabinet bases for traffic signal cabinets.
- 1.02 The foundation base is designed for most cabinets now being used in the field.

2. Description and Use

- 2.01 The foundation base is constructed of polymer concrete and reinforced by a heavy-weave fiberglass mat.
- 2.02 The types and sizes of the bases vary depending on the size of the cabinet to be installed.
- 2.03 Inserts (1/2" anchors) are molded into the base and must align with the cabinet footprint.
- 2.04 Base is resistant to most chemicals.

3. Installation

- 3.01 The following installation procedure is the same for all sizes of foundation pads.
- 3.02 Determine cable/conduit entry position.
- 3.03 Excavate to the proper depth for traffic cabinet signal base. (The base should extend no more than 50% above grade level.)
- 3.04 Excavate the site to the proper depth as determined by the final grade. The work pad may be installed directly on undisturbed soil. (If the soil compaction is substandard, or if you wish to provide drainage, you need to lower the excavation 4" to 6" to accommodate pea gravel.)
- 3.05 Install conduit, 90° bends, to extend at least 2" above final grade of the base.
- 3.06 Compact the soil or pea gravel base.
- 3.07 Install the traffic signal cabinet base. When lowering the base in place, be sure the conduit is straight in line with the opening on the top surface of the base. After setting the base, check for alignment and plumb.
- 3.08 Backfill evenly around the base to maintain alignment and plumb. Tamp backfill after each 4" fill. Fill 1" to 2" above grade and tamp to grade.
- 3.09 Set the cabinet.

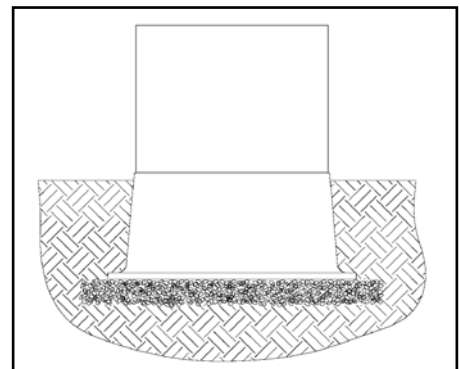

Electrical Equipment Pad Installation

Installation Instructions

1. General

- 1.01 This section covers the description, installation and use of support pads for transformers and switchgear.
- 1.02 The foundation base is designed for use with most transformers and switchgear now being used in the field.

2. Description and Use

- 2.01 The foundation pad is constructed of polymer concrete and reinforced with a heavy-weave fiberglass mat.
- 2.02 Various types and sizes of pads are available for use depending on the size of the equipment to be installed.
- 2.03 Inserts (3/8" or 1/2" anchors) or struts are molded into the pad and must align with the base of the equipment base lugs, or support leg sets.

3. Installation

- 3.01 The following installation procedure is the same for all sizes of foundation pads.
- 3.02 Determine cable/conduit entry position.
- 3.03 Dig recess for pad so that top surface of pad will be level with surrounding area.
- 3.04 Level dirt around cable opening.
- 3.05 Level and tamp down dirt in the area to be occupied by the foundation pad.
- 3.06 Backfill and tamp in trench area leading to cable opening.
- 3.07 Place pad in prepared, level area with opening in pad (throat) directly over cable entry position.
- 3.08 Attach equipment to the foundation pad with bolts, brackets, and/or lugs provided by equipment manufacturer.
- 3.09 Backfill and tamp earth around pad so it is level with surrounding landscape.



Switchgear Box Pad Installation

Installation Instructions

1. General

- 1.01 This section covers the description, installation and use of box pads for switchgear.
- 1.02 The foundation base is designed for use with most switchgear now being used in the field.

2. Description and Use

- 2.01 The foundation box pad is constructed of polymer concrete and reinforced with a heavy-weave fiberglass mat.
- 2.02 Various types and sizes of pads are available for use depending on the size of the equipment to be installed.
- 2.03 3/8" or 1/2" inserts (anchors) or struts are molded into the pad and must align with the base of the cabinet base lugs, or support leg sets.

3. Installation

- 3.01 The following installation procedure is the same for all sizes of foundation box pads.
- 3.02 Determine cable/conduit entry position.
- 3.03 Excavate hole for the box pad. Make hole 1' - 2' longer and wider and approximately 6" deeper than the box pad.
- 3.04 Put bolts into lifting inserts on sides of the box pad (4 bolts are shipped with the box pad).
- 3.05 Attach lifting chain or straps to bolts.
- 3.06 Lift and position box pad into hole using a backhoe. Check plan for proper orientation of box pad.
- 3.07 Place gravel in the box pad to a depth of approximately 6" to 8".
- 3.08 Lift box pad to proper elevation, allowing gravel to run out under the box pad.
- 3.09 Check the elevation of the box pad.
- 3.10 Make necessary elevation adjustments with the bucket and recheck the elevation.
- 3.11 Remove the bolts once the box pad is set to proper elevation.

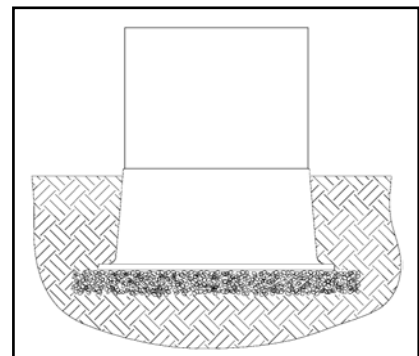

Corporate Divisions



Hubbell Lenoir City, Inc. - Lenoir City, Tennessee

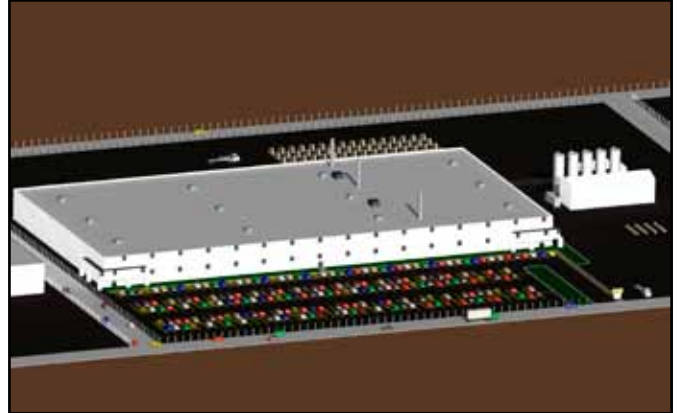

Hubbell Lenoir City, Inc. - Juarez, Mexico

HUBBELL - LENOIR CITY, INC. ***(Lenoir City, Tennessee; Juarez, Mexico)***

Hubbell has polymer concrete manufacturing plants in Lenoir City, Tennessee and Juarez, Mexico, making Hubbell the largest precaster of polymer concrete products in North America. Polymer concrete, which uses polymer resin instead of Portland Cement, is a strong, lightweight, and highly impermeable material.

Both manufacturing plants produce precast polymer concrete products and are able to supply most all of the Quazite products from either facility. The 78,000 square foot Lenoir City facility is conveniently located near both Interstates 40 and 75, a geographically central location that allows it to serve the entire east coast. In 2008, Hubbell built a modern 120,000 square foot facility in Juarez, Mexico, to expand its polymer concrete manufacturing capacity required to service the growing demand from our customers.



Polymer Concrete Products

Polymer concrete products are manufactured at the Lenoir City Division plants in Lenoir City, TN and Juarez, Mexico.



The division has two main product lines:

QUAZITE® utility products, which make up the oldest and largest group, are products engineered for the electrical, water and gas utilities, telecommunications and transportation industries. Underground pull/splice boxes, service boxes, handholes, box pads, and telephone and electric equipment pads are included in the QUAZITE® line. These lightweight products are easier, and therefore less expensive, to install. QUAZITE®'s strength, durability and corrosion resistance means that it will last longer, reducing life cycle costs.

POLYCAST® presloped trench drain is used in a wide variety of applications from airports to major highway systems to light duty residential to industrial plants. POLYCAST® offers easy to install, low-cost channels, catch basins and a variety of gratings which are resistant to chemicals and water erosion.



People and Capabilities



Engineering

Registered Professional Engineers are on hand to assist with design, specification development and review. Full CAD capabilities are available and can be used to electronically transmit drawings and files to you.

Sales and Customer Service

Quazite precast polymer concrete products are sold by a network of stocking distributors throughout the country. In support of the distributors are Sales Representatives knowledgeable in the products and applications. Regional Sales Managers, as well as Product Managers, work to provide customer service and satisfaction.

Competent, friendly, customer service personnel are on staff to respond quickly to customer questions and concerns.

Special care is given by order receipt through plant scheduling, quality control and shipping to meet all needs.



Website

QUAZITE® literature and product drawings are now conveniently available through the Quazite website at www.quazite.com. For the latest revisions and additions to our product line, visit us online at:

www.quazite.com

Research and Development

Quazite is involved in continuous research and development programs. Products are reviewed, updated and improved as changes occur in the market place.

As engineers become aware of the features and benefits of polymer concrete, the range of applications for this unique material continues to grow.

Precast polymer concrete may be the engineering solution for problems associated with traditional materials.



Quality Assurance



Quazite is committed to quality assurance, product improvement and research into new materials and applications. Highly specialized Quality Assurance staff at each manufacturing facility ensure product consistency and conformance to customer specifications.

Standard testing is performed to assure the highest quality products. In addition, other custom tests are performed on a routine basis as required for the application.

Standard physical testing is performed for compressive strength, tensile strength, and flexural strength. The material is tested according to the requirements of ASTM Method D-543, Section 7 for chemical resistance.

As seen from the examples of test procedures shown here, product development and quality have always been emphasized. That emphasis is more prevalent today than ever before and will continue to grow in the future.



Shipping & Inventory

Many different types of products are shipped daily - drain, and utility service boxes.

An extensive inventory is maintained on each product to assure that customers receive a quick delivery.





Complete Product Representation and Stocking Distributors Throughout North America



Web: <http://www.quazite.com>
E-mail: hpsliterature@hps.hubbell.com

QUAZITE
HUBBELL LENOIR CITY, INC.
3621 Industrial Park Drive
Lenoir City, TN 37771
Phone: 800-346-3062 or 865-986-9726
Fax: 865-986-0585
e-mail: hpsliterature@hps.hubbell.com



BUSHINGS • CONSTRUCTION • INSULATION • PROTECTION • SWITCHING • TOOLS

NOTE: Because Hubbell has a policy of continuous product improvement, we reserve the right to change design and specifications without notice.

© Copyright 2011 Quazite • 3621 Industrial Park Drive • Lenoir City, TN

JANUARY 2011

Printed in USA

SUTH 5M

QZ-1